

Carriage Lights Installation

- NOTE:
 1 TIME DELAY RELAY IS USED ONLY WHEN AXLE LIGHT OPTION IS INSTALLED;
 TIMER ALLOWS HID LAMPS TO START AND STABILIZE PRIOR TO HALOGEN LAMPS TURNING ON. THIS BALANCES THE ELECTRICAL LOAD ON THE AVAILABLE CIRCUIT;
 2 SET TIMER TO 5 SECONDS DELAY ON MAKE;

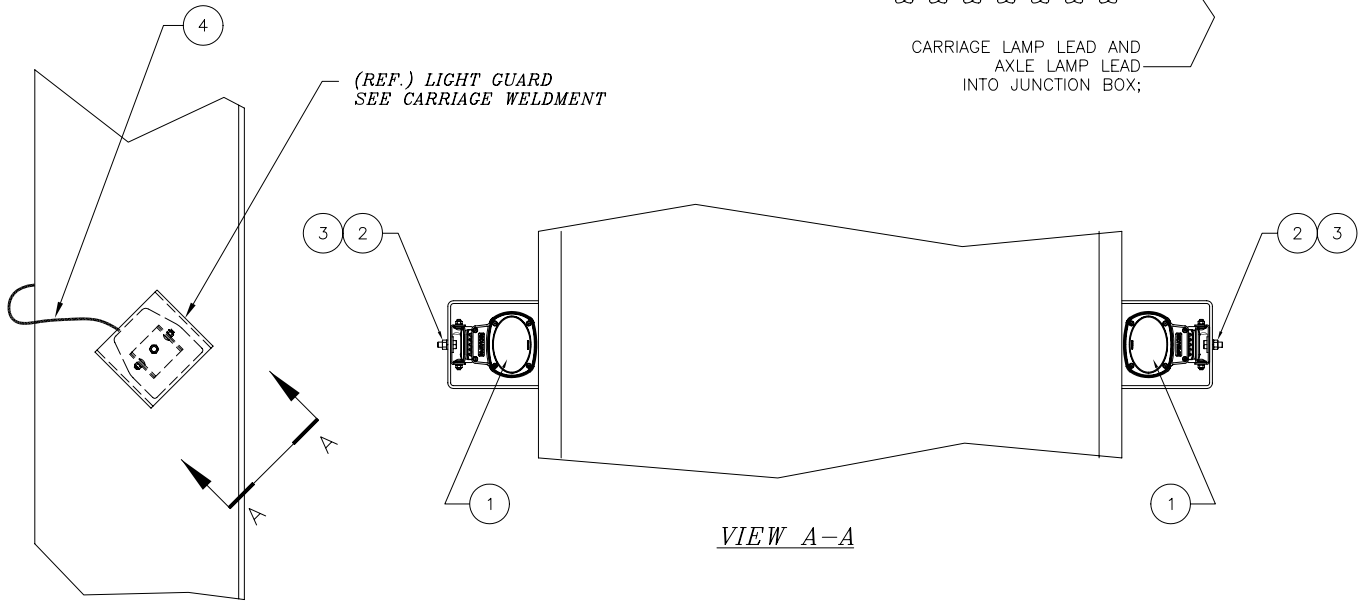
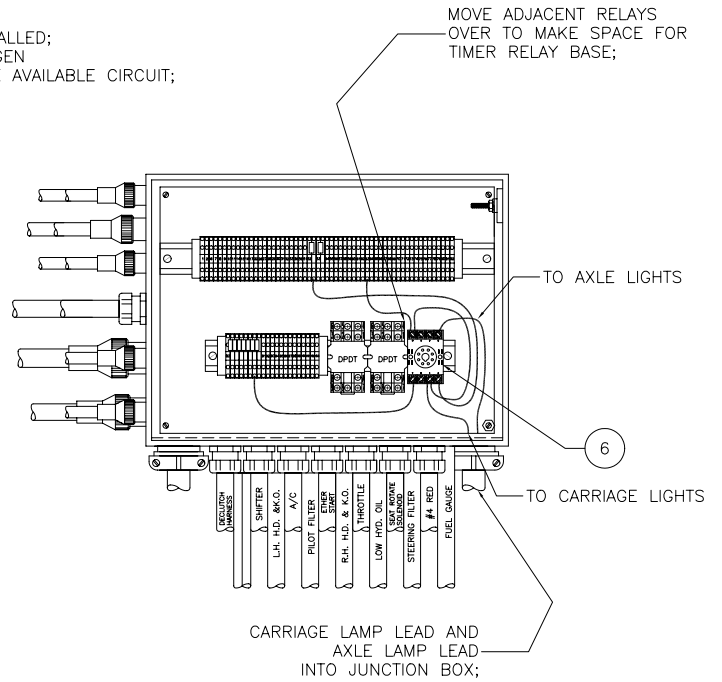
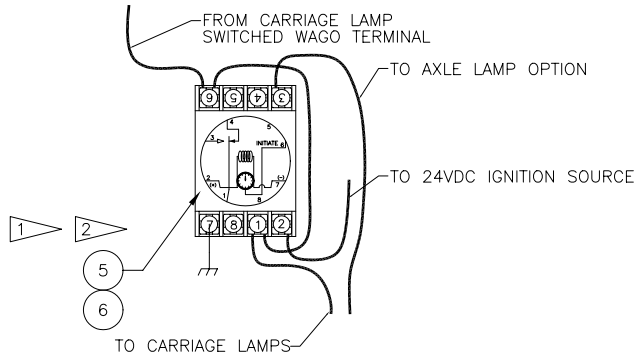

Item	Part No.	Qty	Description	Item	Part No.	Qty	Description
580069 Carriage Lights Installation							
1	249288	2	. Lamp Assembly, Hid Flood	4	540541	1	. Wire Harness,Carr Lights
2	223427	2	. Flat Washer	5	243346	1	. Relay, Time Delay
3	R11499	2	. Locknut	6	220450	1	. Socket, Relay