

---

**Cab Assembly**

## Cab Assembly

Item	Part No.	Qty	Description	Item	Part No.	Qty	Description
	<b>579826</b>		<b>Cab Assembly</b>				
1	578380	1	. Cab	22	223154	2	. Screw, Sheet Metal
2	573878	1	. Glass	24	* 578568	1	. Insulation Installation
3	573879	1	. Glass	25	227299	1	. Knockout Plate
4	573880	1	. Glass	26	569146	1	. Platethreshold
5	574754	1	. Window, Sl Gls	27	09420904	3	. Capscrew
6	579827	1	. Overhead Panel Assembly	28	201635	8	. Capscrew
7	* 579757	1	. Wiper Installation, 24V Front	29	570391	8	. Washer, Sq
8	* 579758	1	. Wiper Installation, 24V Rear	30	224202	8	. Nut, Esna
9	* 573913	1	. Door Assembly/Installation,Cab	31	222615	8	. Flat Washer
10	573896	1	. Light Installation	32	234757	8	. Capscrew
11	203037	55'	. Molding, Locking Key	33	00103339	8	. Flat Washer
12	200326	55'	. Molding, Self Lock	34	574753	1	. Glass
13	568622	3'	. Duct	35	240983	2	. Insert
14	578754	1	. Gas Spring Installation	36	222906	5	. Insert
15	239161	1	. Fan, 7.5	37	575151	1	. Decal
16	219405	3'	. Wire	38	240106	1	. Horn, Forward
17	00109451	3	. Machine Screw	39	R13806527	2	. Capscrew
18	00103338	3	. Flat Washer	41	R13811445	4	. Flat Washer
19	00190637	3	. Nut, Esna				
20	570390	1	. Light, Dome				
21	219435	4'	. Wire				

\* See Separate Coverage

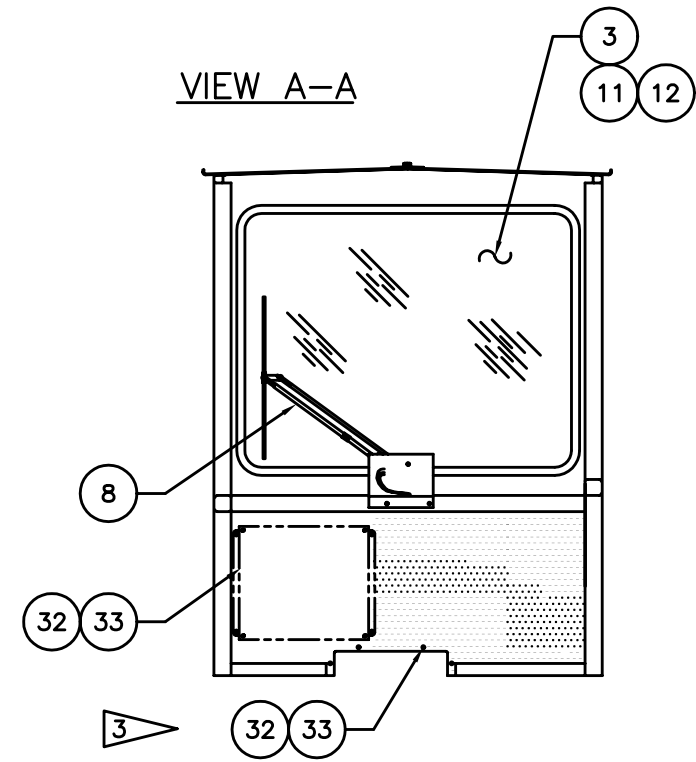
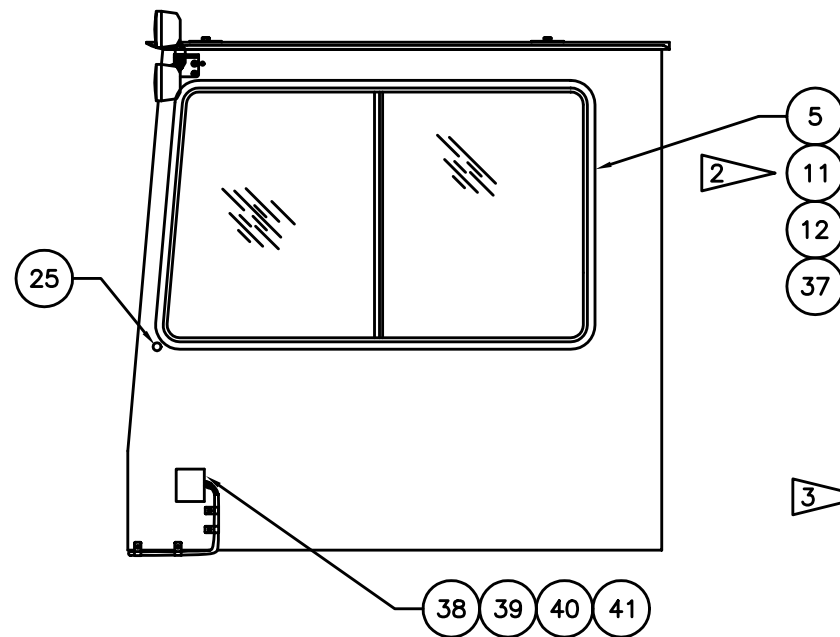
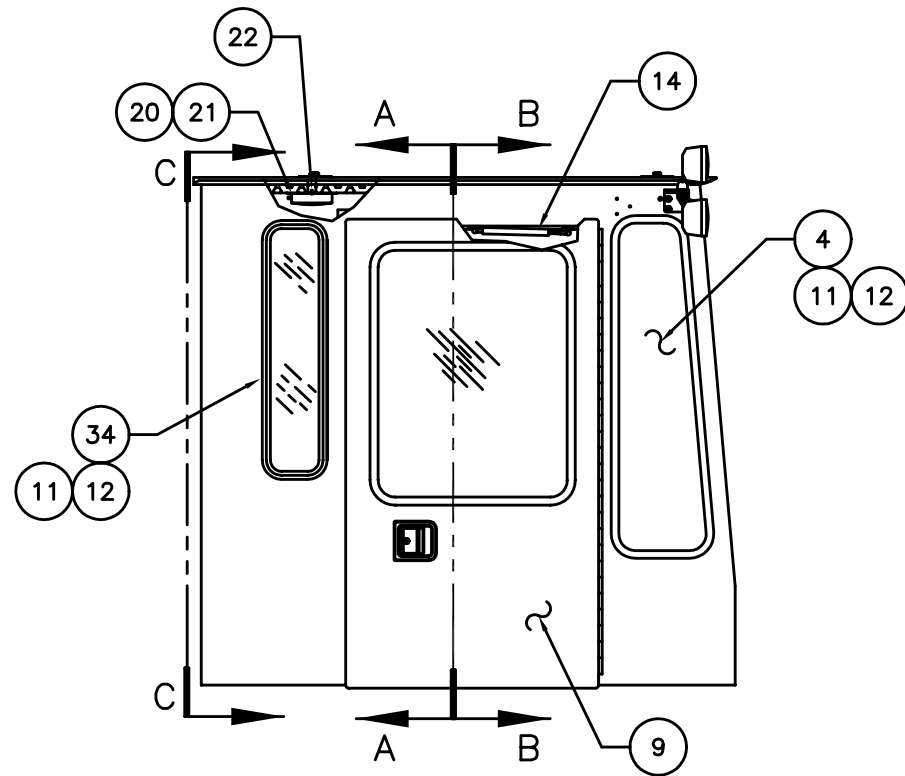
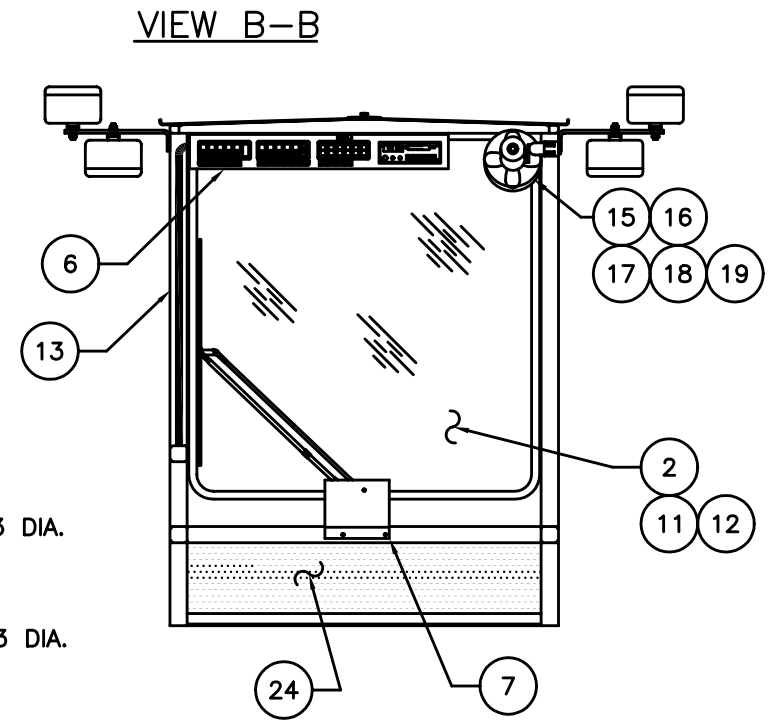
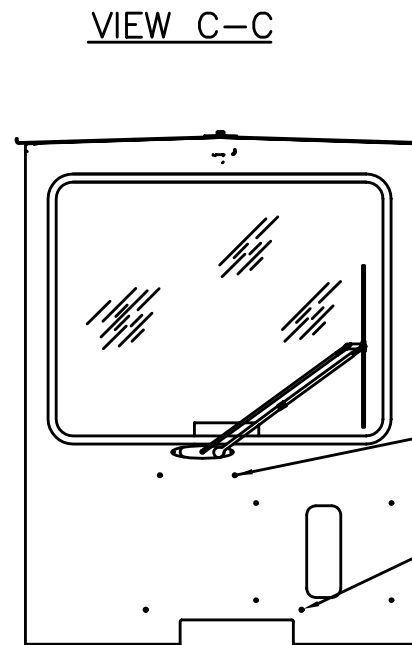
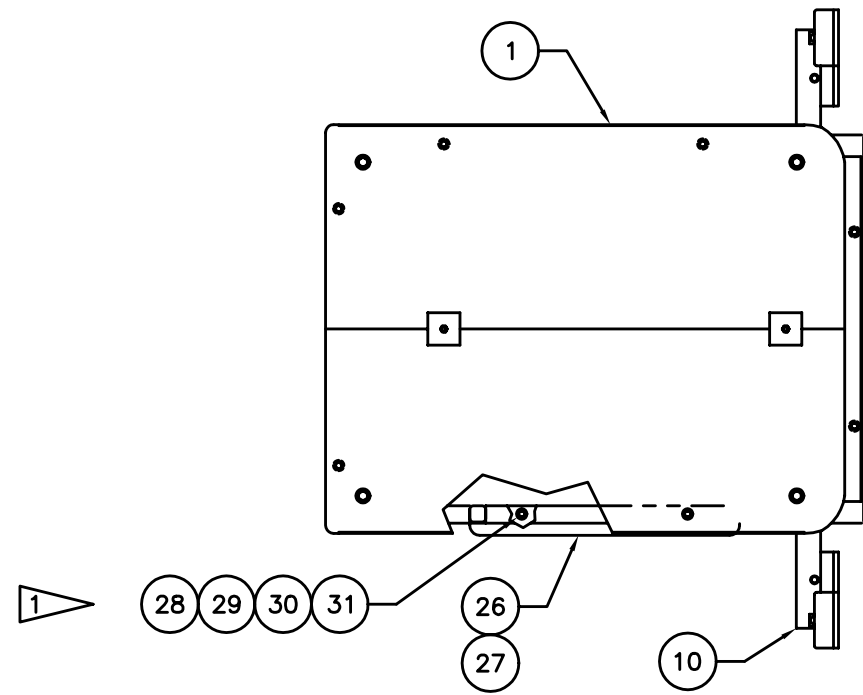

- 1 INSERT CAPSCREWS UP FROM THE COWL FLOOR AT INSTALLATION.
- 2 INSTALL WINDOW WITH LOCKING CORD ON INSIDE OF CAB; LEAVE A 4-6" PIECE OF CORD EXPOSED AT THE FRONT LOWER CORNER OF THE WINDOW. CAP CORD END WITH RED VINYL CAP AND PLACE EMERGENCY EXIT DECAL (ITEM 37) ON CONSOLE NEARBY;

- 3 WHEN MATING THE COWL ASS'Y TO THE CAB ASS'Y, SEAL THE JUNCTION BOX AND COWL TUNNEL TO THE REAR WALL OF OF THE CAB WITH RTV SILICONE SEALER.