

Power Unit

Power Unit

Item	Part No.	Qty	Description	Item	Part No.	Qty	Description
	577564		Power Unit				
1	* 243281	1	. Engine, Caterpillar 3406E	56	223694	8	. Lockwasher
2	* 235291	1	. Conv./Oil Cooler/Aftercooler	57	211791	5'	. Hose, Radiator
3	* 244834	1	. Hydraulic Gear Pump	58	219460	1'	. Hose, Radiator
4	* 244833	1	. Piggyback Pump	59	225370	2	. Clamp, T-Bolt
5	570775	1	. Ring Gear Assembly	60	225369	6	. Clamp, T-Bolt
	570776	24	. . Stud	61	201635	12	. Capscrew
	237315	96	. . Washer, Bellville	62	222151	1	. Fitting
	237316	24	. . Nut	63	23390	3	. Kit, Split Flange
	570735	1	. . Ring Gear		203523	1	. . O-Ring
6	* 234183	1	. Alternator		209539	2	. . Clamp Half
7	225544	3	. V-Belt, Fan Drive		201621	4	. . Capscrew
8	234497	6	. Dampener, Vibration		200604	4	. . Lockwasher
9	505499	2	. Gasket	64	211693	1	. Fitting
10	539968	2	. Sleeve	65	209805	1	. Fitting
11	529449	1	. Ground Strap Assembly	66	240874	1	. Fitting
12	239100	1	. Condenser	67	225129	1	. Fitting
13	238536	1	. Compressor	68	209167	2	. Fitting
14	* 576920	1	. Oil Fill Installation	69	217657	2	. Fitting
15	* 243341	1	. Radiator	70	209420	1	. Fitting
16	577393	1	. Switch Assembly, Prox	71	14857	2	. Fitting
17	243487	1	. Fan, 42	72	11767	2	. Kit, Split Flange
18	243488	4	. Connector		209537	2	. . Clamp Half
19	243489	8	. Clamp		222379	4	. . Capscrew
20	576694	1	. Wire Harnesses, Engine		200604	4	. . Lockwasher
21	239124	1	. Pulley	73	223582	1	. Fitting
22	576711	2	. Mounting, Engine	74	243589	2	. Fitting
23	576717	1	. Engine Mount	75	223909	4	. Lockwasher
24	576723	1	. Wire Harnesses, Engine	78	203528	1	. O-Ring
25	577278	1	. Air Scoop	79	223794	1	. Fitting
26	576748	2	. Bracket	80	221186	1	. Fitting
27	576753	1	. Tube	81	230596	4	. Capscrew
28	576754	1	. Tube	82	237008	2	. Valve, Shutoff
29	576757	1	. Elbow, Reducer	83	223168	2	. Fitting
30	576780	1	. Bracket, Air Conditioner	84	00140807	1	. Nipple, Pipe
31	234899	1	. V-Belt	85	209506	2	. Fitting
32	R1380388920		. Capscrew	86	209504	1	. Fitting
33	00103341	20	. Flat Washer	87	22390	1	. Fitting
34	R13812514	7	. Lockwasher	88	00121208	1	. Nipple, Pipe
35	576781	1	. Plate	89	210732	1	. Fitting
36	576782	1	. Shaft, Spline	90	R14589	1	. Bracket
37	576783	1	. Plate, Flange Adapter	91	223654	1	. Nut, Esna
38	58907W	1	. Snap Ring - Ext	92	243553	1	. Fitting
39	203541	2	. O-Ring	93	* 576917	1	. Dipstick & Hosing Installation
40	R13809440	2	. Capscrew	94	244427	1	. Spacer, Fan
41	578009	1	. Tube	95	23945	1	. Fitting
42	576800	1	. Angle	96	* 239790	1	. Pump, Brake/Pilot
43	576801	1	. Angle	97	243714	1	. Bushing
44	230866	1	. V-Belt	98	243743	1	. Pulley
45	223428	6	. Flat Washer	103	209579	1	. Clamp
46	224117	6	. Nut, Esna	104	209304	2	. Fitting, St
47	224202	2	. Nut, Esna	105	209932	1	. Hose Assembly
48	R13802628	4	. Flat Washer	106	26838	1	. Fitting, St
49	209421	2	. Fitting	107	578662	1	. Bracket Weldment
50	234896	6	. Capscrew	108	R13801909	1	. Capscrew
51	00106268	6	. Flat Washer	109	R13811451	3	. Washer, Flat
52	578361	12	. Flat Washer	110	* 576899	1	. Engine Configuration, CAT 3406
53	223188	6	. Nut, Esna				
55	223692	8	. Capscrew				* See Separate Coverage

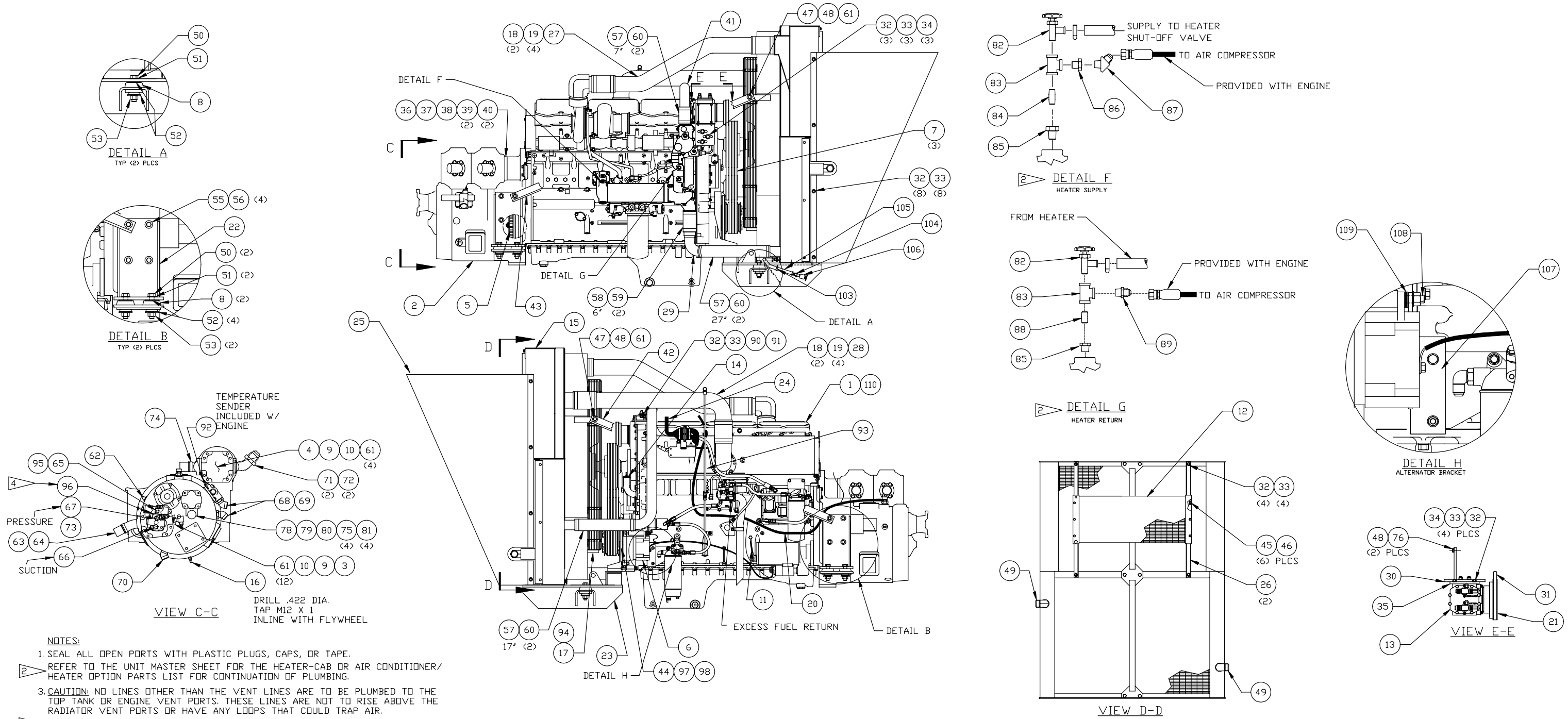

NOTES:

1. SEAL ALL OPEN PORTS WITH PLASTIC PLUGS, CAPS, OR TAPE.
2. REFER TO THE UNIT MASTER SHEET FOR THE HEATER-CAB OR AIR CONDITIONER/ HEATER OPTION PARTS LIST FOR CONTINUATION OF PLUMBING.
3. **CAUTION:** NO LINES OTHER THAN THE VENT LINES ARE TO BE PLUMBED TO THE TOP TANK OR ENGINE VENT PORTS. THESE LINES ARE NOT TO RISE ABOVE THE RADIATOR VENT PORTS OR HAVE ANY LOOPS THAT COULD TRAP AIR.
4. INSTALL PUMP (ITEM 96) WITH CASE DRAIN ORIENTED UP

DRILL .422 DIA.
TAP M12 X 1
INLINE WITH FLYWHEEL