

Brake Assembly, Auxiliary & Parking

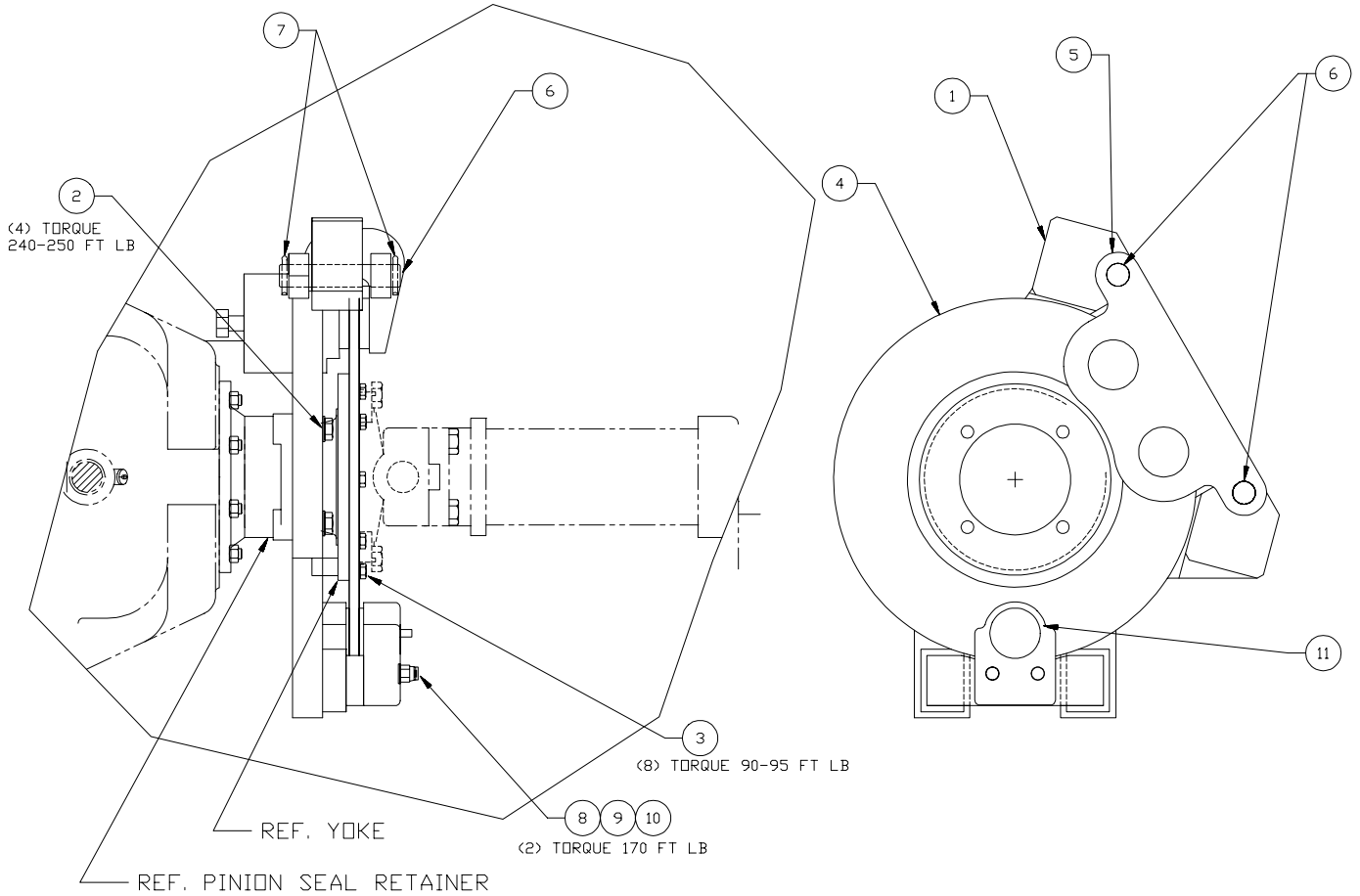

| Item | Part No. | Qty | Description | Item | Part No. | Qty | Description |
|------|---------------|-----|---|------|----------|-----|-------------------------|
| | 577219 | | Brake Assembly, Aux. & Parking | | | | |
| 1 | 577308 | 1 | . Brake Anchor | 8 | 231656 | 2 | . Capscrew |
| 2 | 234893 | 4 | . Capscrew | 9 | 16747 | 4 | . Washer, Flat |
| 3 | 214048 | 8 | . Capscrew | 10 | 224211 | 2 | . Nut, Esna |
| 4 | 577280 | 1 | . Brake, Disc | 11 | * 244410 | 1 | . Brake Caliper |
| 5 | * 244409 | 1 | . Parking Brake Caliper | | | | * See Separate Coverage |
| 6 | 577287 | 2 | . Pin | | | | |
| 7 | 00103422 | 4 | . Pin, Cotter | | | | |