

wagner

L4100F



Purpose-Built Log Handlers

Specifications are subject to change without notice or obligation.

 **MADE IN USA**

L4100F

L4100F Capacity	Standard	High Lift	Super High Lift
Tipping Capacity	123,000 lbs @ 54" LC	119,000 lbs @ 48" LC	110,000 lbs @ 48" LC
Rated Capacity	100,000 lbs @ 54" LC	100,000 lbs @ 48" LC	90,000 lbs @ 48" LC

Engine (Tier III available until end of 2017)

Make and Model Cummins QSX15
Max Horsepower 535 HP

Optional:

Make and Model Caterpillar C15
Max Horsepower 540 HP

Service Refill Capacities

Fuel Tank 425 Gal (1,609 liters)*
Hydraulic Oil 575 Gal (2,177 liters)*
Engine w/Filter 12 Gal (45 liters)*
Cooling System 34 Gal (129 liters)*

Torque Converter

Flex Drive Converter with Pump Drives

Transmission

4 Speed FWD/REV Powershift Transmission

Axles

Front Axle with Posi-Torque Differential and Wet Brakes Planetary Final Reduction
Rear Axle with Standard Differential and No Brakes Planetary Final Reduction

Tires

Single Drive Tires Standard
 Front (2) 37.25 x 35
 Rear (2) 29.50 x 29
Dual Drive Tires Optional
 Front (4) 24.00 x 35
 Rear (2) 29.50 x 25
Biased Ply Tire Construction Standard
Radial Tire Construction Optional

Cab

Best in class working environment includes the following:

Noise (dBa) Inside Cab (ISO 6396:2008) 72 dB
Visibility 360°
Convex Front Windshield Standard
Falling Objects Protection (F.O.P.) Certification Standard
Heat/AC Standard
Air Seat Suspension for Operator Comfort Standard
Cab Isolation from Chassis (Noise/Vibration Reduction) Standard
Rotating Platform, 90° Standard
Sliding Windows Optional
Load Dampening Optional
Joystick Steering Optional

Features & Options

Wet Disc Brakes Standard
Remote Engine Oil Drain Standard
Stairwell Access Standard
Central Lube Standard
Sight Gauges Standard
Manually Activated ANSUL Fire Suppression (Liquid) Standard
LED Lights Standard
HID Lights Optional
Auto Lube System Optional
Automatic Fire Suppression System Optional
Tilt Cab Optional
Front and Rear Cameras with Monitor Optional
Warning Beacon Optional
Converter Lockup Optional

* Approximate

L4100F

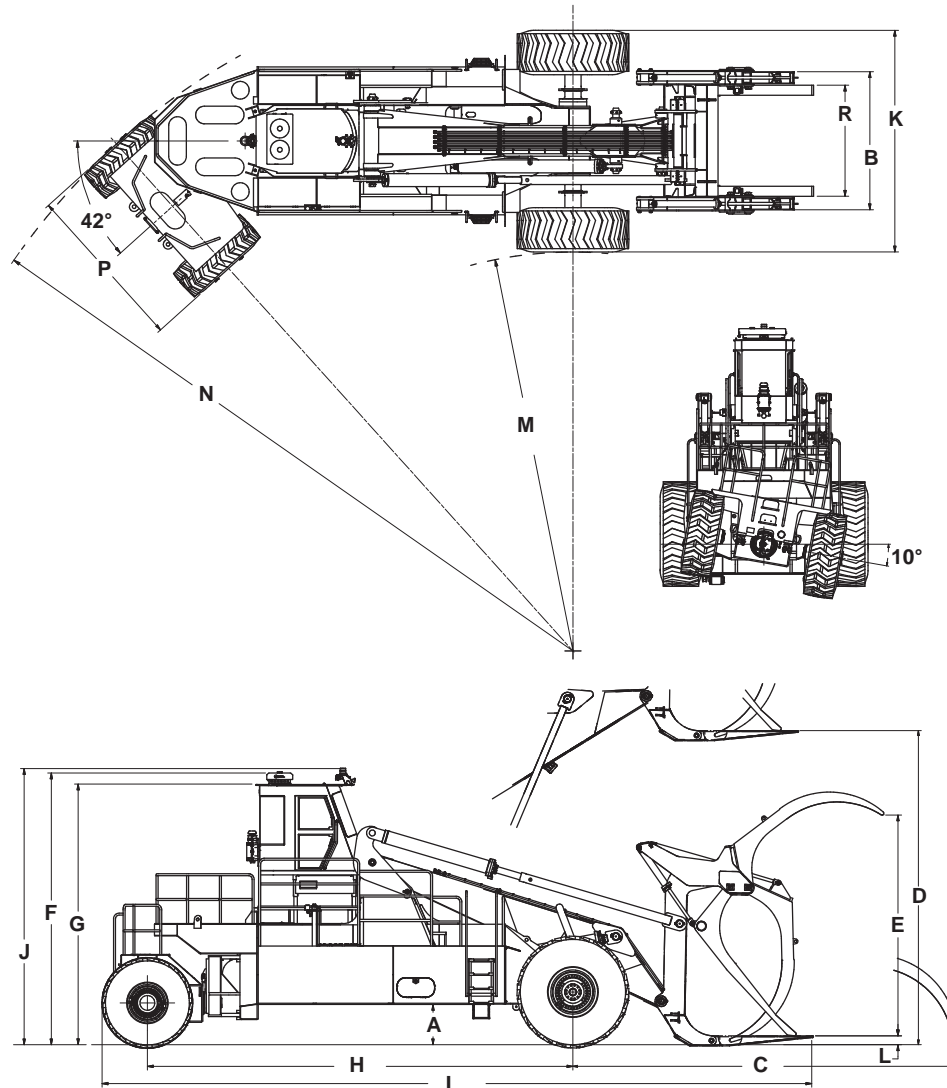

L4100F Dimensions*

	Standard	High Lift	Super High Lift
A. Ground Clearance	2' 10" (869 mm)	2' 10" (869 mm)	2' 10" (869 mm)
B. Carriage Width	9' 9" (2,975 mm)	9' 9" (2,975 mm)	9' 9" (2,975 mm)
C. Distance from Axle to HD Tip for Reach	26' 0" (7,925 mm)	26' 10" (8,191 mm)	26' 10" (8,191 mm)
D. Lift Height	16' 7" (5,055 mm)	22' 2" (6,767 mm)	24' 0" (7,315 mm)
E. Mouth Opening	15' 7" (4,759 mm)	15' 7" (4,759 mm)	15' 7" (4,759 mm)
F. Cab Height w/AC	19' 3" (5,857 mm)	19' 3" (5,857 mm)	19' 3" (5,857 mm)
G. Cab Height	18' 5" (5,608 mm)	18' 5" (5,608 mm)	18' 5" (5,608 mm)
H. Wheelbase	30' 1" (9,169 mm)	30' 1" (9,169 mm)	30' 1" (9,169 mm)
I. Length	47' 10" (14,580 mm)	50' 2" (15,291 mm)	50' 2" (15,291 mm)
J. Cab Height (highest point)	19' 6" (5,952 mm)	19' 6" (5,952 mm)	19' 6" (5,952 mm)
K. Width	15' 8" (4,776 mm)	15' 8" (4,776 mm)	15' 8" (4,776 mm)
L. Ground to Front Tip of Tine	8" (193 mm)	8" (193 mm)	8" (193 mm)
M. Inside Turning Radius	28' 2" (8,598 mm)	28' 2" (8,598 mm)	28' 2" (8,598 mm)
N. Swing Radius	48' 3" (14,700 mm)	48' 3" (14,700 mm)	48' 3" (14,700 mm)
P. Width Outside of Bogie Tires	11' 10" (3,609 mm)	11' 10" (3,609 mm)	11' 10" (3,609 mm)
R. Width Across Tines	7' 10" (2,394 mm)	7' 10" (2,394 mm)	7' 10" (2,394 mm)

Weights*

Standard and High Lift (100,000 lb capacity):

Unit Weight (Empty)162,000 lbs (73,482 kg)
 Unit Weight (Loaded)262,000 lbs (118,841 kg)

Super High Lift (90,000 lb capacity):

Unit Weight (Empty)163,000 lbs (73,934 kg)
 Unit Weight (Loaded)253,000 lbs (114,759 kg)

Speed (Unladen)

1 4.4 mph (7.1 km/h)
 2 7.6 mph (12.2 km/h)
 3 12.7 mph (20.4 km/h)
 4 22.4 mph (36.0 km/h)

Custom carriage options are also available

*Approximate



wagner

A Division of Allied Systems Company

21433 S.W. Oregon Street
Sherwood, Oregon 97140 USA
Telephone: 503.625.2560 • Fax: 503.625.7980
E-mail: wagner@alliedsystems.com
www.alliedsystems.com