

Lubrication LC90

Proper and consistent lubrication of articulation points on your Wagner is vital to the longevity of your machine.

Note: The drivelines require a different grease than the rest of the machine. See Fluids chart in Section 10-1, or the tables on page 2 for details.

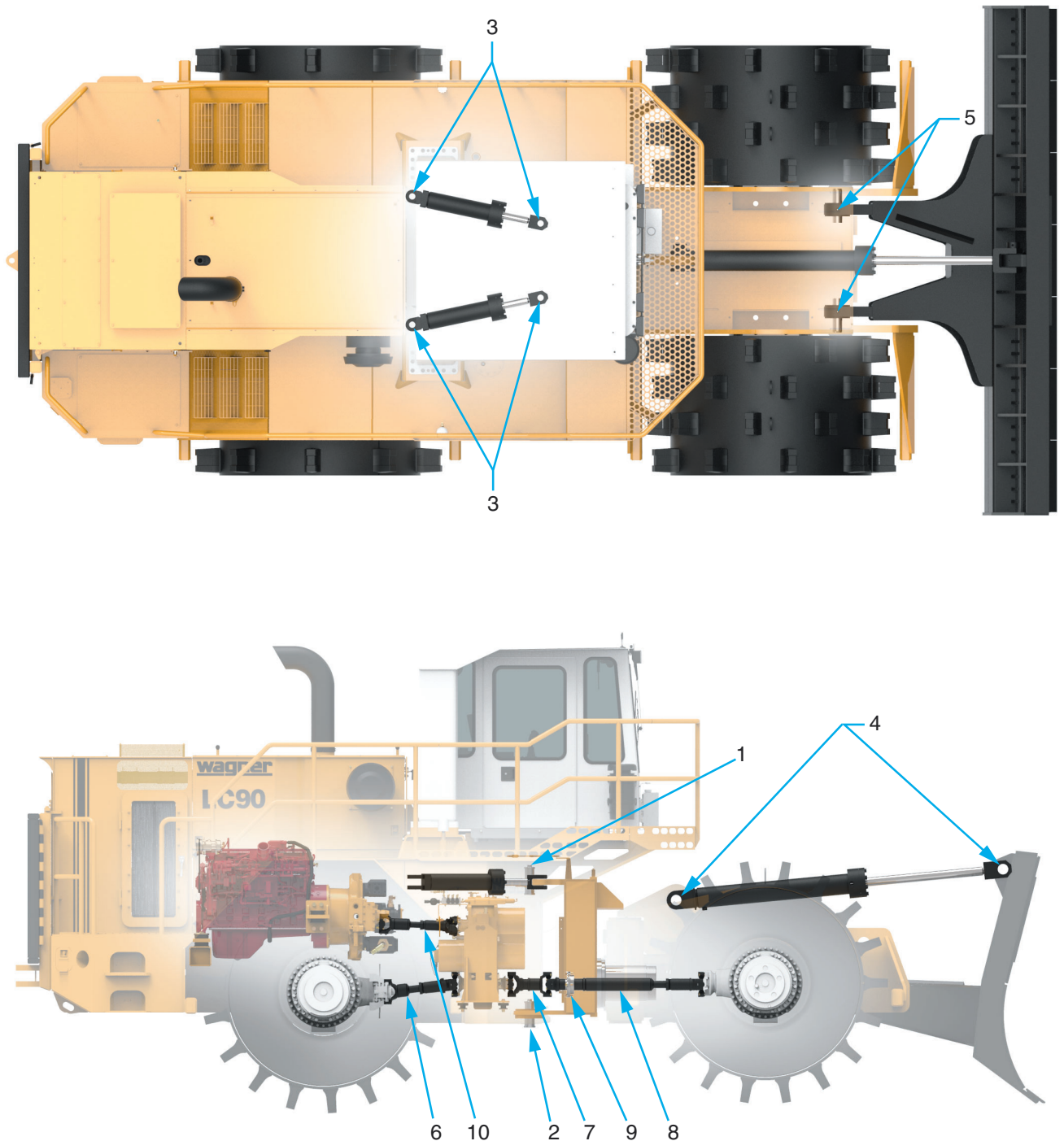

Figure 1 Lubrication Points

Lubrication Schedule

Refer to Figure 1.

10 Hours

Before engine startup, check the following:

①	Hinge Pin - Upper *b	Mobilgrease Special No. 2
②	Hinge Pin - Lower *b	
③	Steering Cylinder Pins *b	
④	Hoist Cylinder Pins *b	
⑤	Bogie to Blade Pins *b	

50 Hours

⑥	Driveline - Transmission to Rear Axle *a	Mobilith SHC 220 Grease
⑦	Driveline - Transmission to Swivel *a	
⑧	Driveline - Swivel to Front Axle *a	
⑨	Driveline - Support Bearing *a	
⑩	Driveline - Transmission to Converter *a	

*a Use handgun or lower pressure adaptor; lubricate sparingly.

*b Accessible at the central lube manifolds, if so equipped.

Optional Central Lube

Units with the optional central lube installed may be lubricated at the manifolds accessible near the swivel on the left side of the machine. See Figure 2. These points provide remote access to all lube points listed above, except for the drivelines. Those will still need to be lubricated at the drivelines themselves.

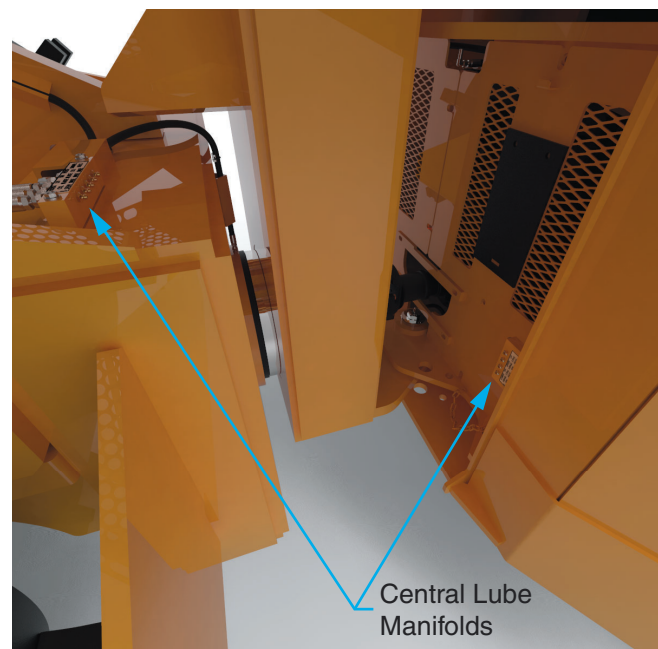

Figure 2 Optional Central Lube Points