

## Daily/Shift Maintenance

Note general vehicle condition. Clear away all collected debris, open belly pans, clean out engine compartment, and steam clean if necessary. Check for mechanical damage and loose or leaking components. Report all faults to maintenance department.

**Always refer to manufacturer's (e.g. engine, transmission, axle) maintenance manual before performing any maintenance.**

Before Starting Engine, Check the Following:				
Ref	Component	OK	NO	ADD
1	ENGINE (Check oil level - check for leaks)			
2	ENGINE BELT (Check for adjustment and wear)			
3	FUEL/WATER SEPARATOR (Drain Water)			
4	HYDRAULIC TANK (Check oil level - check for leaks)			
5	RADIATOR & OIL COOLER (Check coolant level - check for leaks; are fins clean and unobstructed?)			
6	AIR CLEANER/INTAKE SYSTEM (Check indicator - clean / change element if indicator shows red, empty dust cup, check for leaks / damage)			
7	WHEELS (Check condition)			
8	TORQUE WHEEL NUTS (Daily for first 50 hours, every 100 hours thereafter)			
9	LUBRICATE CHASSIS (Refer to lube chart)			
10	WALK AROUND INSPECTION OF STRUCTURE (Check welds, open belly pans, check for leaks, damaged components, etc...)			
11	FIRE SAFETY CHECK (Check for accumulated debris in engine compartment, etc)			
12	FIRE SUPPRESSION SYSTEM (Verify certifications are current)			
13	TRANSMISSION (Check oil level)			

After Starting Engine, Check the Following:				
Ref	Component	OK	NO	ADD
14	ENGINE (Does it sound normal?)			
15	INSTRUMENTS AND CONTROLS (Check for normal readings and functioning)			
16	AIR INTAKE SYSTEM (Inspect all connections)			
17	EXHAUST SYSTEM (Check for leaks and excessive smoke)			
18	TRANSMISSION (After warming to operation temp, check oil level - check for leaks)			

Note Anything Abnormal or in Need of Repair:	
Component	Comments
LIGHTS	
DEFROSTER	
REVERSE WARNING HORN	
HORN	
WINDSHIELD WIPERS	
HEATER	
AIR CONDITIONER	

OPERATOR \_\_\_\_\_

SUPERVISOR \_\_\_\_\_

DATE \_\_\_\_\_

MODEL \_\_\_\_\_

SERIAL No \_\_\_\_\_

HOURLY METER \_\_\_\_\_

## Daily Maintenance Procedures

### General

The following maintenance procedures should be performed at the beginning of each work shift. The numbers before each maintenance procedure correspond to the numbers on the charts on the previous page.

### Before Starting Engine

#### 1. Engine

The oil level should be checked prior to starting the engine. The engine oil dipstick is accessed from the deck on the right side of the machine (See Figure 1). Make sure that the area around the dipstick is clean and the machine is sitting on level ground.

**NOTE: A 15 minute drain-back time is recommended if the engine has been running.**

The oil level must be maintained between the “L” (low) mark and the “H” (high) mark, but as close to the “H” mark as possible.



## CAUTION

Never operate the engine with the oil level below the “L” mark or above the “H” mark. Refer to the engine’s Operation and Maintenance manual for detailed engine service information. Use only approved engine oil (see Lubricant Specifications Chart, Section 10). Do not overfill. Check engine for leaks.

Engine Oil Fill Port

Engine Oil Dipstick



Figure 1 Engine Oil Dipstick & Fill Tube

#### 2. Engine Belts

If engine belts are loose or worn, report to maintenance for corrective action. Consult the manual supplied with your engine for belt inspection procedures.

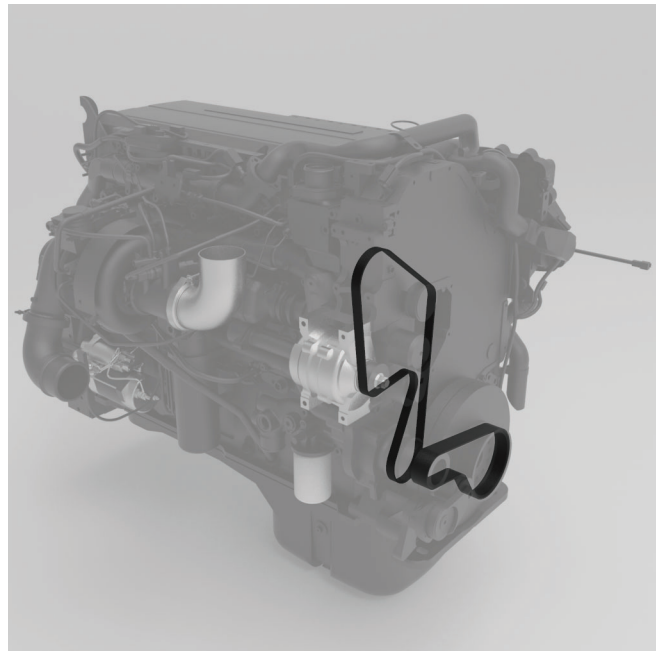

Figure 2 Engine Belts

#### 3. Fuel/Water Separator

Drain water from the fuel/water separator. See section 2-1 in your service manual for detailed instructions.

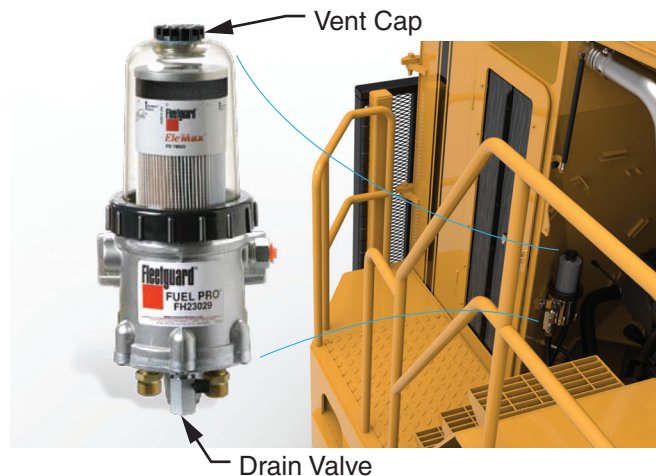

Figure 3 Fuel/Water Separator

## 4. Hydraulic Oil Level

### **WARNING**

Always open the tank breather petcock (located on the breather pipe) before removing the filter cover plate or the plug in the cover plate. Failure to vent tank can result in injury or a substantial oil spill. Be sure to close the petcock before operating the machine.

Always check the hydraulic oil level prior to operation. The sight glasses for the main hydraulic tank are located on the front right corner of the chassis, under the deck.

Fill the main hydraulic tank by removing the plug in the filter cover plate, and adding oil. **Important: See warning on this page for tank venting procedure.** Fill the main hydraulic tank until the oil shows in the upper sight glass (See Figure 4).

The oil level should be checked with the hoist cylinder extended (down). The oil level should be at or near the upper sight glass for the main tank. Fill with approved hydraulic fluid as required (see Lubricant Specifications Chart). Do not overfill.

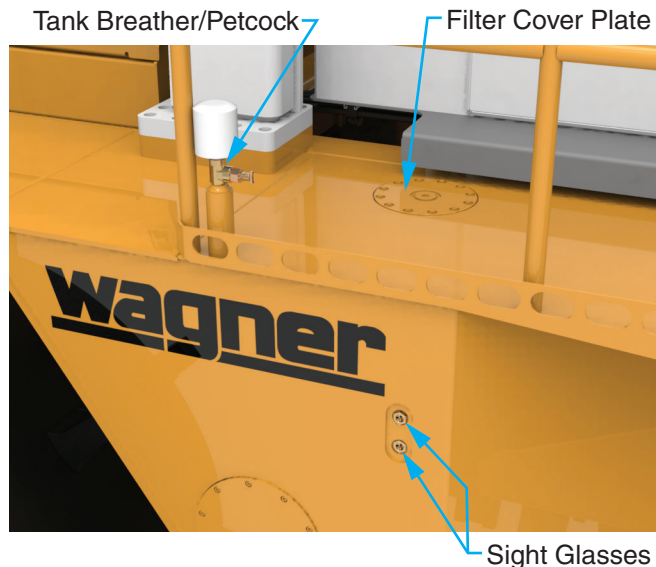

Figure 4 Hydraulic Oil Sight Glass and Fill

## 5. Engine Coolant Level

Daily inspection of the coolant level is recommended. The coolant level sight glass is located on the surge tank (see Figure 5). Fluid level checks should be done on level ground. Remember to compensate for the loss of antifreeze when adding water.

**NOTE: If the engine is hot, the coolant will be higher than when it is cold. Inspect the radiator daily for restriction caused by leaves, paper or bent fins. Inspect the radiator cap, hoses and connectors for any signs of leakage or damage.**

### **WARNING**

**Never remove the radiator cap if the engine is hot. The coolant will be under pressure and could flash to steam with explosive force, causing severe burns. Remove the radiator cap only when the engine is cool.**

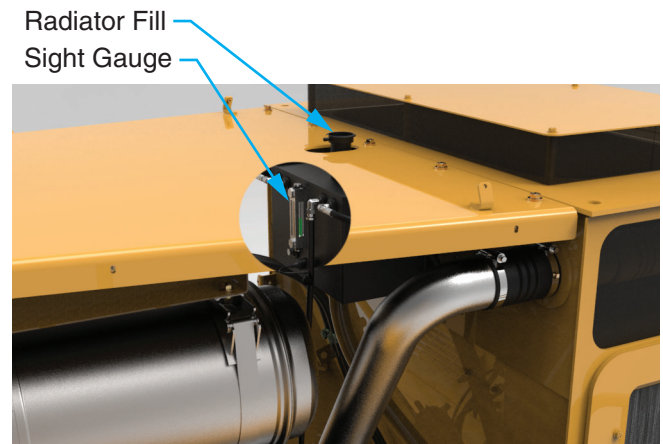

Figure 5 Coolant Fill and Sight Gauge

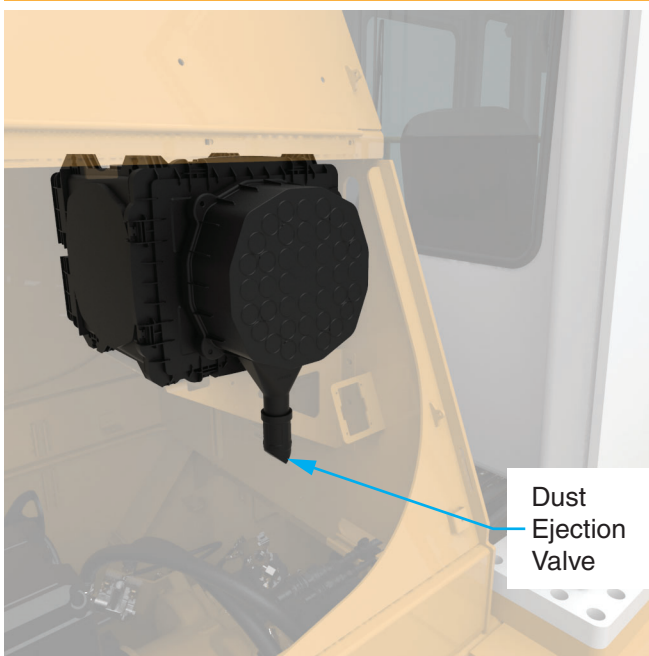

Figure 6 Air Filter

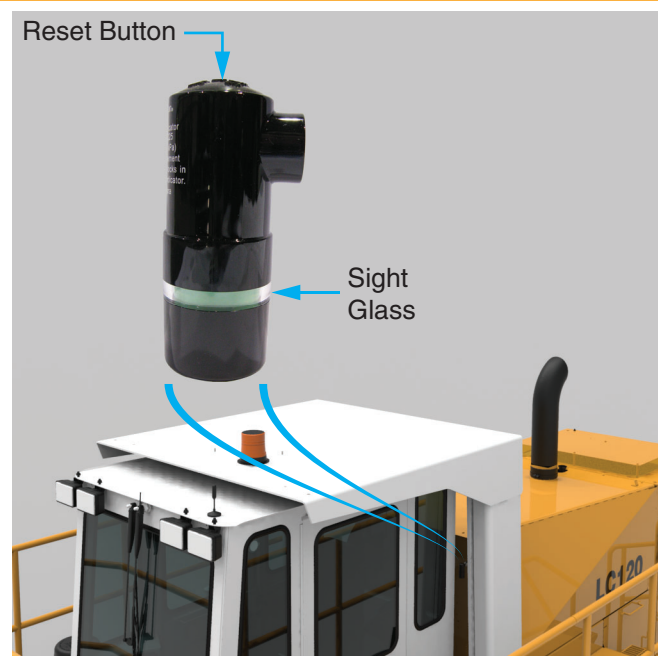

Figure 7 Air Filter Service Indicator

## 6. Air Cleaner/Intake System

The air cleaner is a two stage dry air filter. A service indicator shows the condition of the filter. The indicator will show in the green zone when the filter is clean (See Figure 7). The indicator will show red if the filter is restricted. If red appears in the indicator window, clean or change the element and press the reset button on the indicator (See Figure 6).

## 7. Wheels

Check the wheel assemblies for cracks, loose or missing lug nuts, broken studs, cleats, etc. Report any problems to maintenance.

## 8. Torque Wheel Nuts

Torque the wheel nuts daily for the first 50 hours, and every 100 hours thereafter. To eliminate over-torque, always use a torque wrench and torque to **500 ft-lbs**. See form 80-891 in your service manual for details.

## 9. Lubricate Chassis

Refer to Section 10.

## 10. Walk Around Inspection Of Structure

Walk around the machine and inspect for structural cracks. If cracks are present, repair before resuming operation. Refer to Allied Service Form 80-850 for information on how to properly weld structural cracks.

## 11. Fire Safety Check

Inspect for and remove all combustibles from engine area. These materials build up in tight corners and are highly combustible. Open the belly pans to inspect and clean out the engine compartment and inspect the driveshafts.

Inspect the driveshaft and park brake for debris and remove as necessary.

## 12. Fire Suppression System

If so equipped, check the certification of your fire suppression system. Ensure that the system is fully charged, and bottles or containers are full. Consult the documentation that came with your system for details.

## 13. Transmission Oil Level

The transmission oil dipstick and fill tube are accessed from the front right hand side of the chassis behind the guard (see Figure 8). Lift the rubber flap to access the dipstick.

Always check the transmission oil level prior to starting the engine to be sure there is oil in the sump. The cold oil level must be above the "L" (low) mark on the dipstick.

## After Starting Engine

### 14. Engine

After starting, check that the engine runs and sounds normal. It should come up to operating temperature and pressure within a few minutes after starting. Refer to the operation and maintenance manual for your engine for details. If you notice unusual noises or excessive smoke, have maintenance check it out.

### 15. Instruments and Controls

Check all instruments for normal readings immediately after starting engine. Make sure that pressures and temperatures are within acceptable limits. Also, check that all controls function properly. They should be smooth and responsive. See Section 2 for details.

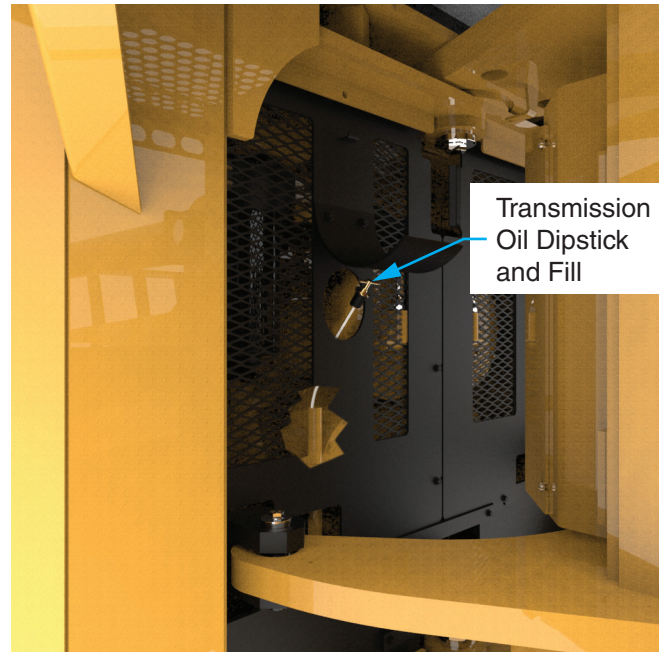

Figure 8 Transmission Oil Dipstick and Fill

### 16. Air Intake System

Inspect all connections for damage, loose clamps, and air leaks. Look for damaged fittings and loose connections. Do not operate the machine if leaks are present. Dirt could enter the engine intake and cause severe damage. See Section 10.

### 17. Exhaust System

Check for leaks. Make sure that exhaust gases are not entering the operator's cab. Mounting brackets must be in place and all connections tight. Check for excessive smoke.

### 18. Transmission Oil Level

The transmission oil dipstick and fill tube are accessed from the front right hand side of the chassis (See Figure 8). The level should be checked again after the engine warms up, with 180°F to 200°F showing on the transmission temperature gauge.

Check oil level with engine running at idle, at operating temperature, and with the transmission in neutral. The level should be between the "H" (high) and "L" (low) marks. Fill with approved fluid only (see Section 10). Do not overfill. Inspect for leaks.



**INTENTIONALLY LEFT BLANK**