

Filter Service

Effective fluids filtration is vital to the longevity and performance of your Wagner. See the previous section on preventive maintenance for the scheduled intervals for filter element replacement where applicable.

Some filter elements (the air cleaner elements, for example) do not have an established service interval, but must be changed based on need. Variations in environmental conditions result in different servicing requirements.

See Figure 1 for the location of the filters on your machine. See Figure 18 for engine filter locations. Refer to the parts manual or suggested stocking guide (SSG) for your machine for part numbers of filter elements. You should always have a full set of replacement elements in stock for your machine. Contact your dealer for details.

Refer to the following pages for timing and procedures of filter element replacement.



WARNING

Severe burn hazard.

Lubricating oils are extremely hot while the machine is running, and may cause severe burns or death upon contact.

Shut down the machine, employ lockout/tagout procedures, and allow the machine to cool. Wear appropriate personal protective equipment when changing fluids or filter elements.

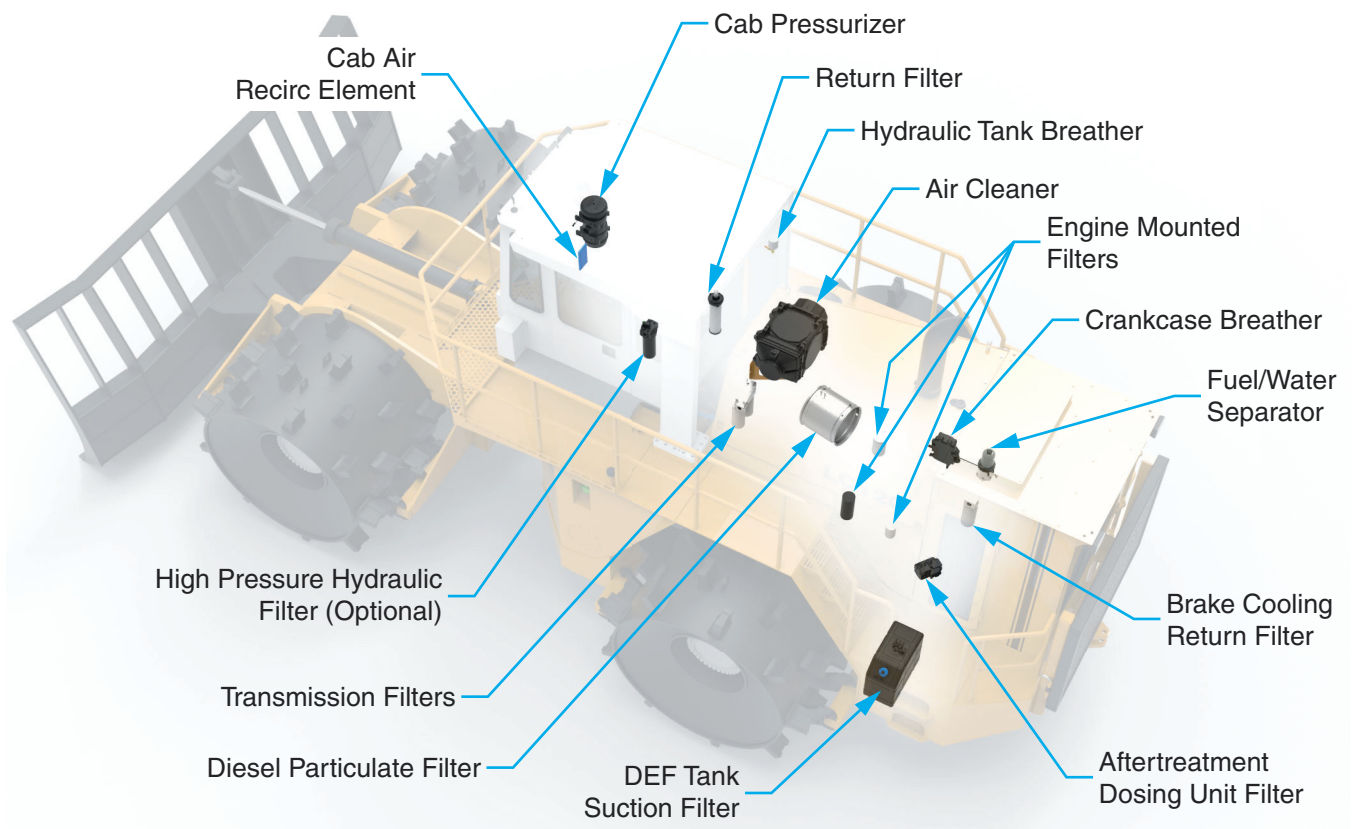

Figure 1 Filter Arrangement

High Pressure Filter

Service Interval: Quarterly, every 500 hours, or when a warning appears on the Wagner smart screen, whichever occurs first.

The high pressure filter is mounted next to the transmission and swivel box behind the transmission guard, on the right side of the machine. See Figure 2.

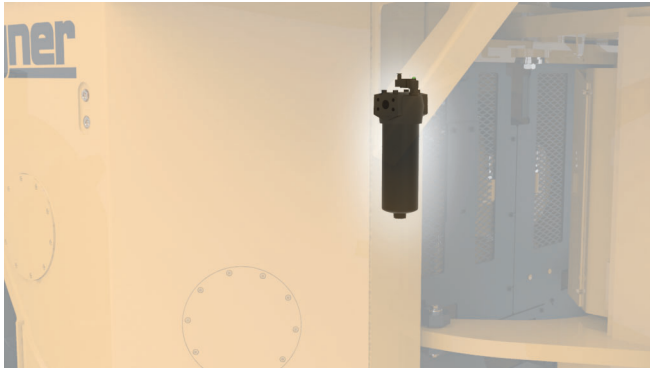

Figure 2 High Pressure Filter Location

Service Instructions

1. Stop system power and vent captive pressure.
2. Drain filter assembly.
3. Remove bowl and element assembly.
4. Push down to squeeze tangs and lift element (see Figure 3).



Figure 4

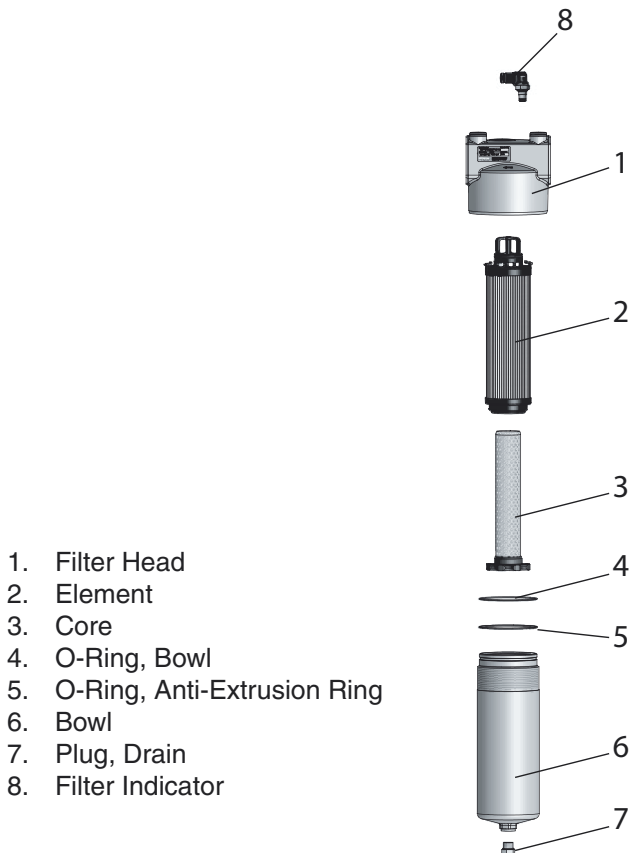

Figure 3 Parts Identification

5. Twist to remove core (see Figure 4).



Figure 5

6. Retain reusable core (see Figure 6).



Figure 6

7. Discard used element.
8. Insert reusable core into new element (see Figure 7).



Figure 7

9. Push element assembly into bowl until tangs snap (see Figure 8).



Figure 8

10. Inspect O-ring and anti-extrusion ring.
11. Install bowl with new element (see Figure 9).
12. Torque bowl (25-30 ft-lb/35-40 N-m) and drain plug (25-30 ft-lb/35-40 N-m).
13. Power up and inspect.



Figure 9

Breather Filter

Service Interval: Monthly, every 250 hours, whichever occurs first.

The breather filter is on the deck on the right side of the machine. See Figure 10.

Replacing the Breather

1. Shut down the machine and vent captive pressure by opening the petcock at the breather. See Figure 10.
2. Clean the surrounding area.
3. Remove the breather and replace with a new one.
4. Close the petcock.

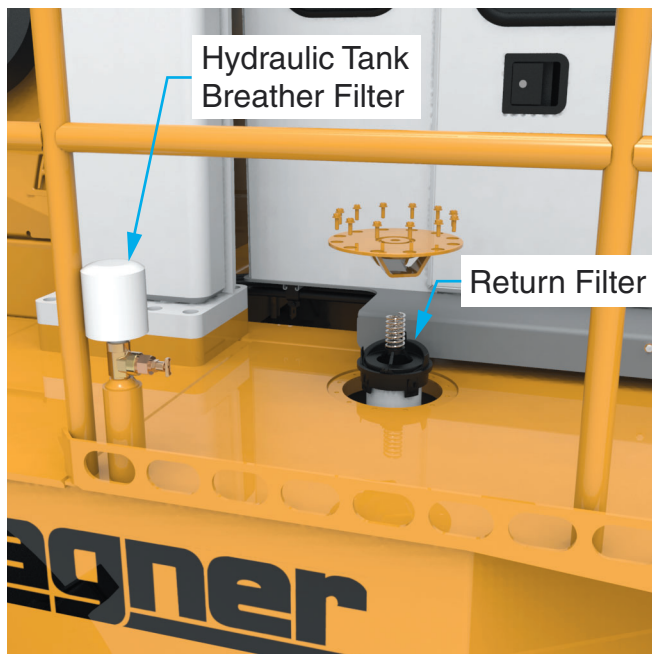

Figure 10 Return Filter and Breather Filter

Return Filter

Service Interval: Quarterly, every 500 hours, or when a warning appears on the Wagner smart screen, whichever occurs first.

The return filter is accessed from the deck on the right side of the machine. See Figure 10.

Allow the machine to warm up. If, after the hydraulic oil is warm, the warning message shown in Figure 11 appears on the Wagner Smart Screen Display, both filter elements must be changed before returning the machine to work, even if prior to the quarterly/500 hour interval.

Replacing the Filter Elements

1. Shut down the machine and vent captive pressure by opening the petcock at the breather. See Figure 10.
2. Clean cover plate and surrounding area.
3. Remove cover plate and gasket.
4. Remove in-tank filter assembly.
5. Remove contaminated cartridge with a twisting motion.
6. Discard disposable element (2).

Before Installing Cartridge

1. Check all seals and tank cover gasket and replace if necessary.



Figure 11 Return Filter Restriction Warning

To Assemble and Install New or Cleaned Cartridge

1. Clean all components.
2. Lubricate and install all seals.
3. Insert new element.
4. Reinstall in-tank return filter into housing (make sure the top spring is secure).
5. Reinstall cover. Torque cover nuts (see 80-1057 Torque Specification Chart).
6. Close the petcock.

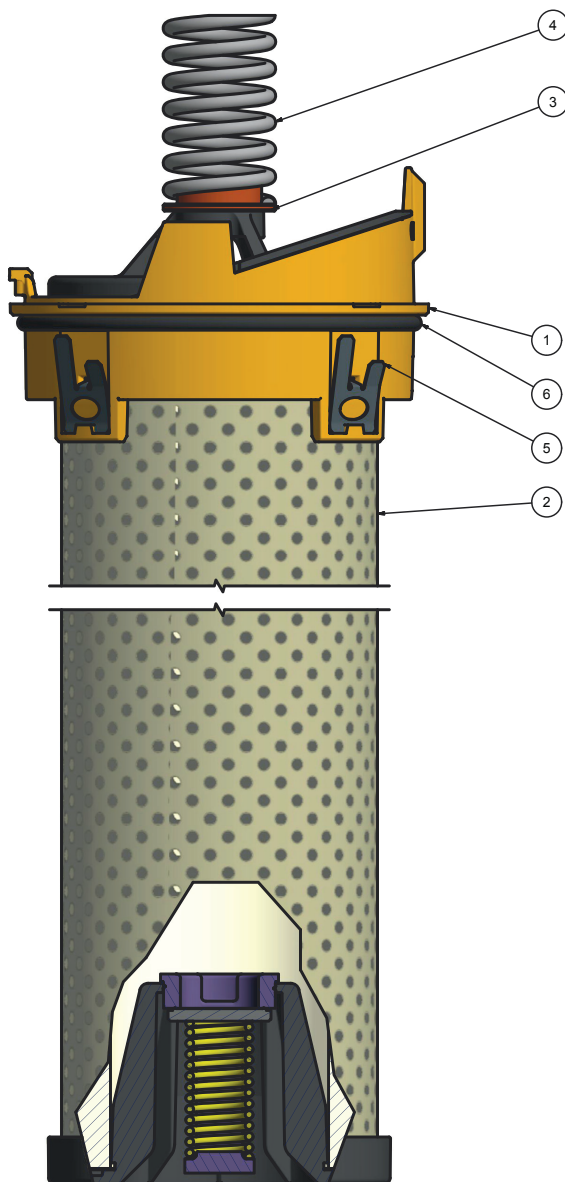

- | | |
|----------------------|-----------------|
| 1. Ring, Adapter | 4. Spring, Top |
| 2. Element, 5 Micron | 5. Clip, Spring |
| 3. Locator, Spring | 6. O-Ring |

Figure 12 Return Filter Assembly

Cab Air Recirculation Element

The cab air recirculation element is located in the cab, behind the cover near the throttle pedal. See Figure 13.

Service Interval: Semi-annually, every 1,000 hours, or when the cab pressurizer element is replaced, whichever occurs first.

Service Instructions

1. Shut down the machine.
2. Remove the cover.
3. Remove and discard the element.
4. Clean the filter mounting areas.
5. Install new filter element.
6. Install the cover.

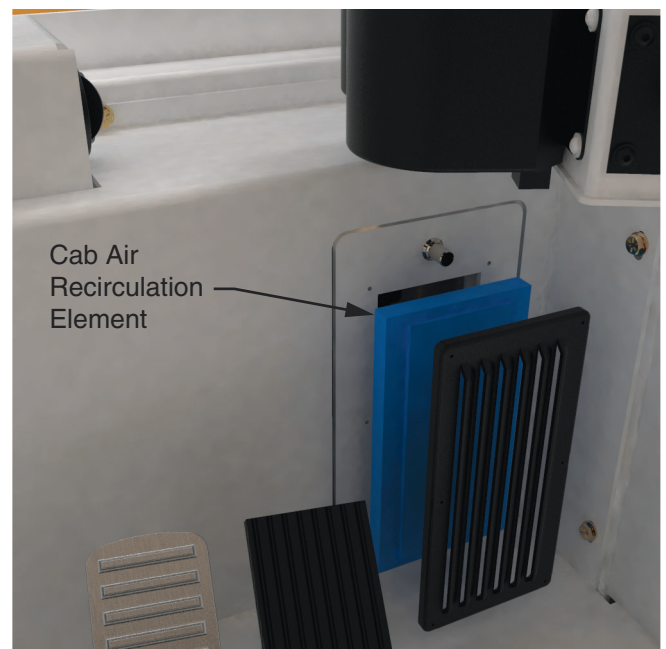

Figure 13 Cab Air Recirculation Elements

Transmission Filters

Service Interval: Quarterly or every 500 hours, whichever occurs first.

The transmission filters are accessed from the left chassis walkway, behind the LH Hood Door. See Figure 14.

Service Instructions

1. Shut down the machine.
2. Clean the area around the filter elements before removing them.
3. Remove the transmission filter elements with a filter wrench and discard.
4. Clean the mating surface of the filter head before installing the new filter elements.
5. Install the new transmission filter elements with a filter wrench.

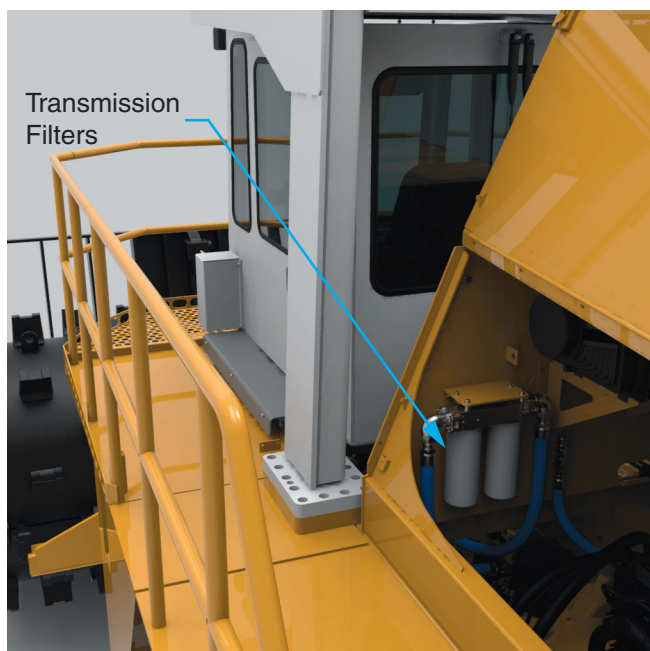

Figure 14 Transmission Filters

Brake Cooling Return Filter

Service Interval: Quarterly or every 500 hours, whichever occurs first.

The brake cooling return filter is accessed from behind the left hand cooling package door. See Figure 15.

Service Instructions

1. Shut down the machine.
2. Open vent on hydraulic tank to relieve residual pressure
3. Clean the area around the filter element before removing.
4. Using a filter wrench, remove the brake cooling filter element and discard.
5. Clean the mating surface of the filter head before installing the new filter element.
6. Using a filter wrench, install the new brake cooling filter elements.
7. Close vent on hydraulic tank before starting vehicle.

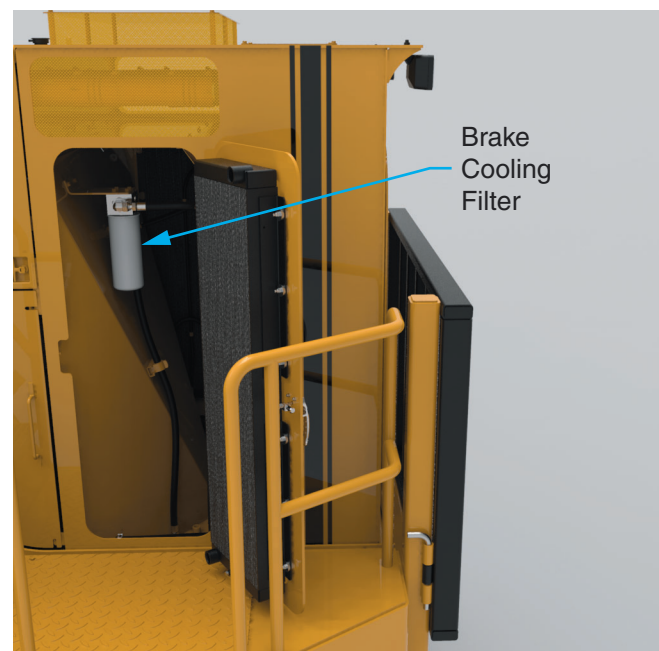

Figure 15 Brake Cooling Return Filter

Cab Pressurizer Filter Element

The cab pressurizer is mounted to the right side of the cab. See Figure 16.

Service Interval: Semi-annually, every 1,000 hours, or when a noticeable drop in cab pressure occurs, whichever occurs first.

Service Instructions

1. Work in a clean covered area to reduce operator and HVAC exposure to harmful particles.
2. Wear appropriate personal protection equipment such as gloves, mask, and coverall to protect against contaminants.
3. The machine should be off.
4. Inspect the system for any damage.
5. Release the 4 filter latches that retain the filter element noting the orientation of the ejection ports when applicable.
6. Once the filter latches are released remove the filter element. Note: Place thumbs on the exterior hardware for additional leverage when removing filter element.
7. Bag and seal used filter element and dispose of according to local regulation.
8. Inspect and remove any loose debris using a clean rag – never use compressed air.
9. Before installing the new filter, inspect for proper operation.
 - i. Turn on the system, staying clear of the open end of filter housing.
 - ii. Ensure that air is blowing out of the empty filter housing cavity.
 - iii. Turn off the system.
10. Install new filter element ensuring the ejection port orientation, when applicable, is correct and that the filter element end cap seats properly on the filter housing.
11. Restrain the filter element by reattaching the 4 filter latches.



CAUTION

When cleaning equipment, care should be taken to prevent high pressure water or High Pressure air from entering the ejection slots.

When replacing the filter, do not point ejection slots at a solid surface in close proximity to the slots.

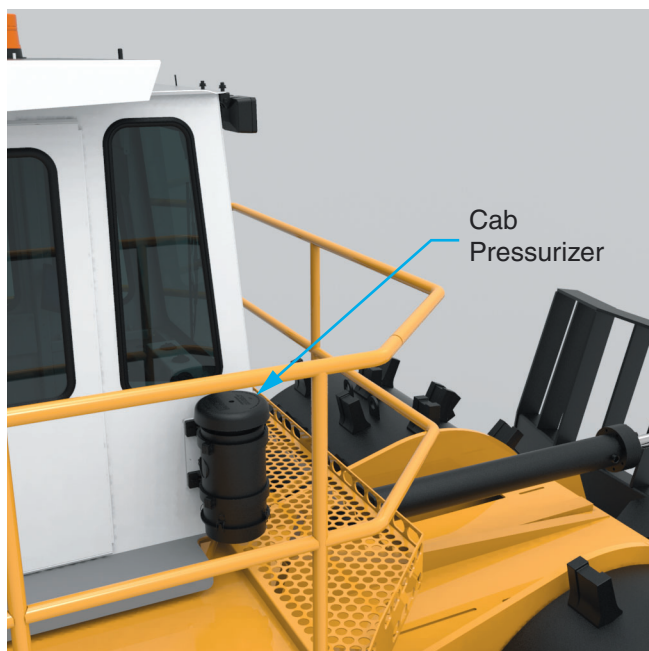

Figure 16 Cab Pressurizer

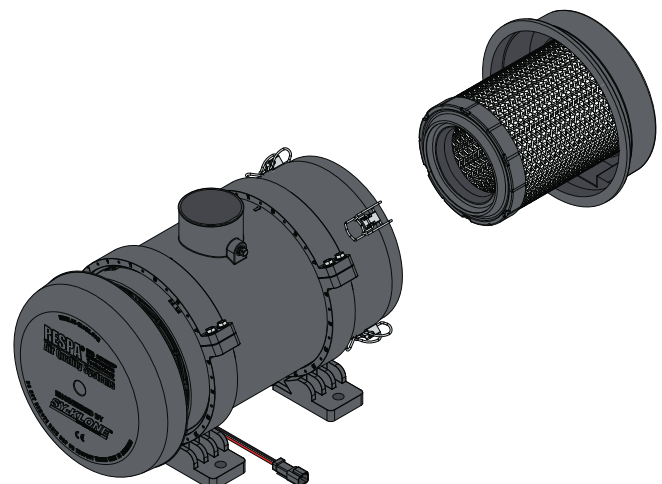

Figure 17

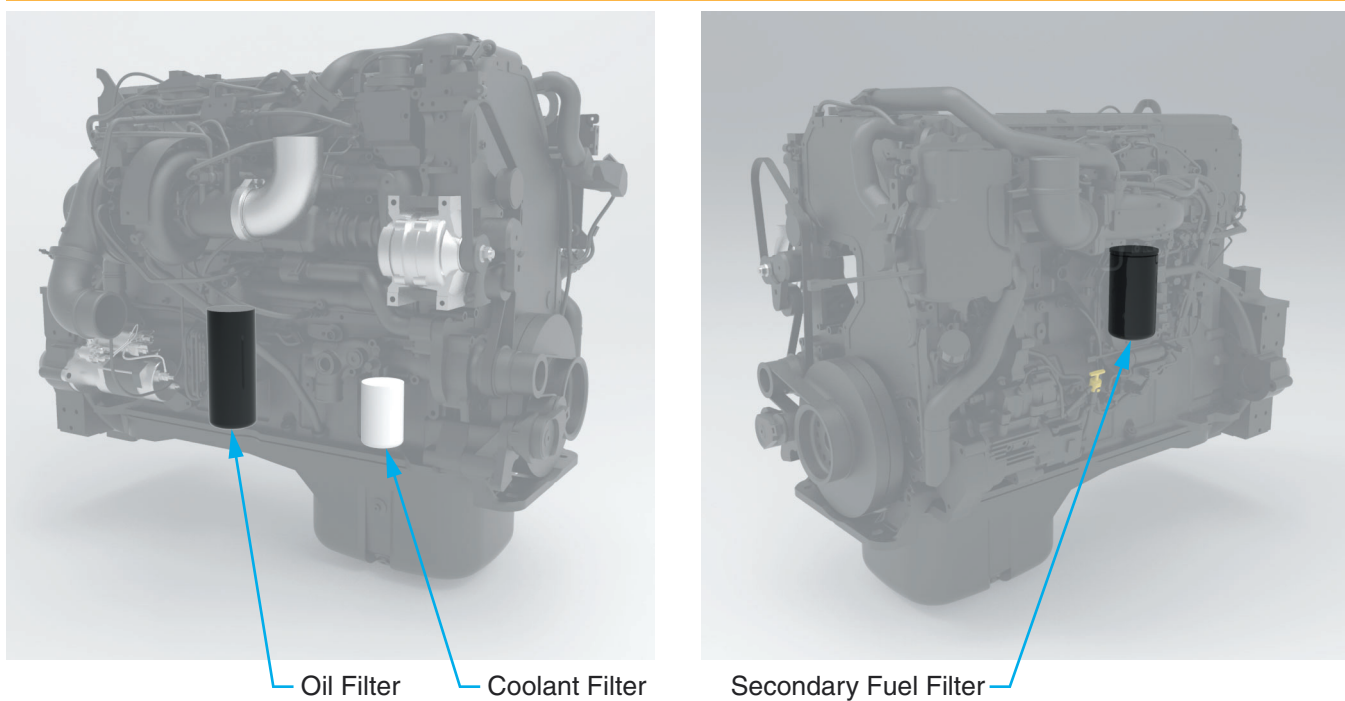

Figure 18 Engine Mounted Filters

Engine Mounted Filters

Engine mounted filters include the engine oil filter, the secondary fuel filter, and the coolant filter. See Figure 18.

Service Intervals:

Engine Oil Filter: Quarterly, every 500 hours, or as dictated by a fault code, whichever occurs first.

Secondary Fuel Filter: Monthly, every 250 hours, or as dictated by a fault code, whichever occurs first.

Coolant Filter: Annually, every 1,500 hours, or as dictated by a fault code, whichever occurs first.

The normal service intervals will be sufficient in most cases. Occasionally, the engine may throw a fault code indicating that a filter element needs to be replaced sooner. The filter element must be replaced prior to returning the machine to work, even if prior to the scheduled interval.

Refer to Section 2 of your Wagner Service Manual for the fault codes for your machine.

Refer to the Operation and Maintenance Manual supplied with your engine for filter change procedures.

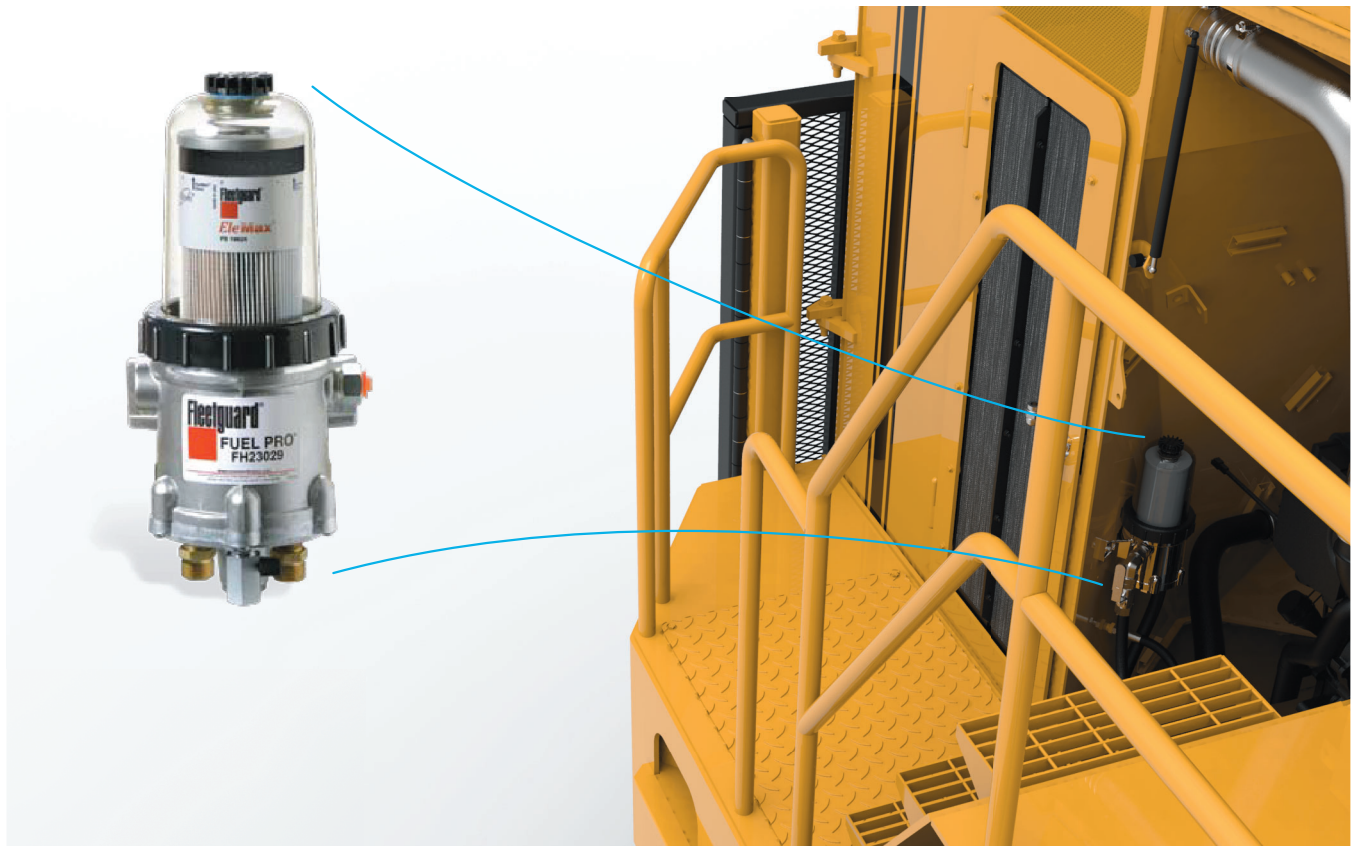

Figure 19 Fuel/Water Separator

Fuel/Water Separator

Service Interval: Monthly, every 250 hours, or as dictated by a fault code, whichever occurs first.

The Fuel/Water Separator is accessed on the right side of the machine, near the engine. See Figure 19.

See section 2-1 of your service manual for servicing procedures.

Air Cleaner

Service Interval: Monthly, every 250 hours, or when indicator dictates, whichever occurs first.

Variations in environmental conditions may affect the service interval. Obviously, dustier environments will require more frequent element changes.

Therefore, the indicator must be checked at least once per shift, and the elements replaced if necessary, even if before the annual interval. This indicator is mounted on the front left side of the hood assembly (see Figure 20).

General

The air cleaner is critical to the life of the engine. It prevents dust and debris from entering the engine air system, causing premature engine wear and possible failure. It is accessed from the right chassis walkway, behind the RH hood door. See Figure 21.

Air Filter Service Indicator

This gauge indicates filter element condition without filter disassembly. The service sight gauge indicates filter contamination by showing “red” or “green” in the sight gauge. The visible amount of red on the indicator will increase as the dust in the element increases.

For maximum engine performance, the filter should be changed or cleaned immediately after the “red” signal locks in full view.

To reset the service gauge, press the button on the top of the gauge.

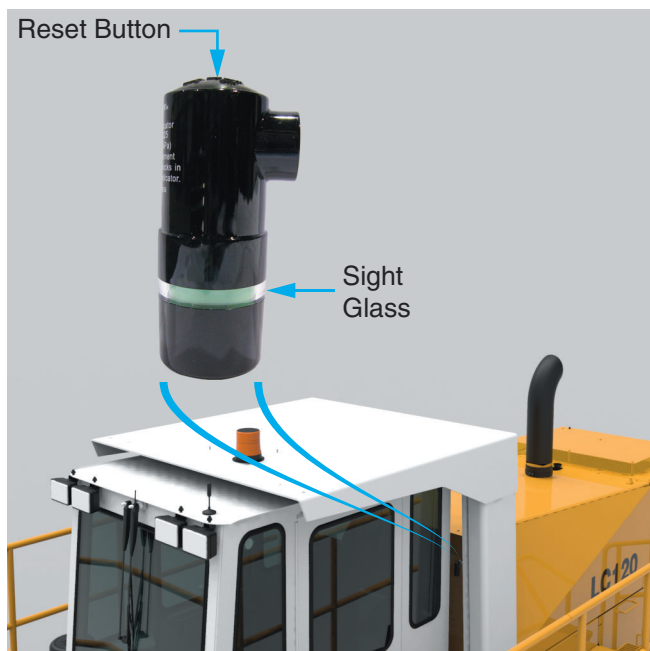

Figure 20 Air Cleaner Indicator

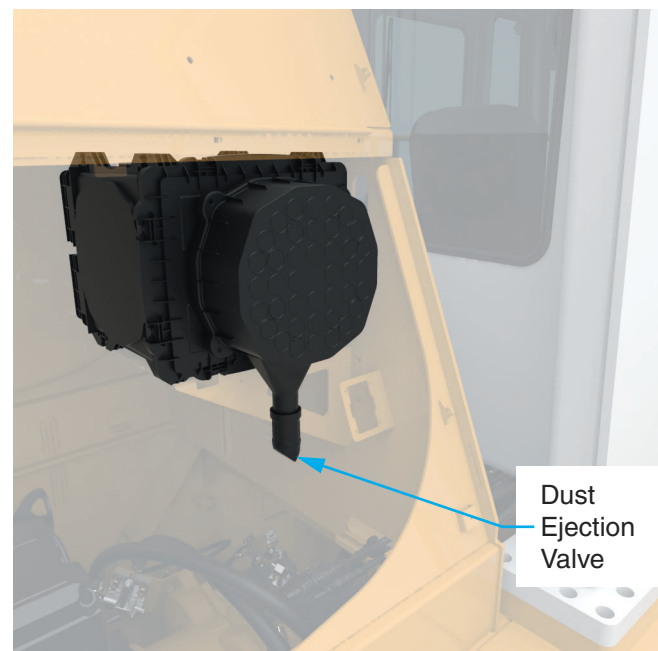

Figure 21 Air Cleaner Location

Air Cleaner Connections

Check the intake tubes between the air cleaner outlet and the turbocharger for cracks or wear, and that all clamps are in place and are tight.

Replace any worn or damaged tubes and tighten any loose clamps.

Service Instructions

1. Shut off engine. Unlatch the 8 metal latches around the filter service cover.



Figure 22 Unlatch 8 Places

2. Remove the filter service cover.



Figure 23 Remove Service Cover

3. Remove the two primary filter elements. Discard in accordance with local regulations.



Figure 24 Remove Primary Elements

4. Remove the two secondary filter elements. Discard in accordance with local regulations.



Figure 25 Remove Secondary Elements

5. Clean the inside of the housing with a damp cloth.
6. Replace the two secondary and two primary filter elements with new elements.
7. Replace the filter service cover and close the metal latches.

Crankcase Breather Element

Service Interval: Every 3000 hours. *

The crankcase breather element is accessed on the right side of the engine. See Figure 26.

Consult with the Operation and Maintenance Manual supplied with your engine for servicing procedures.

* Service interval may be reduced if the ECM indicates excessive crankcase pressure.

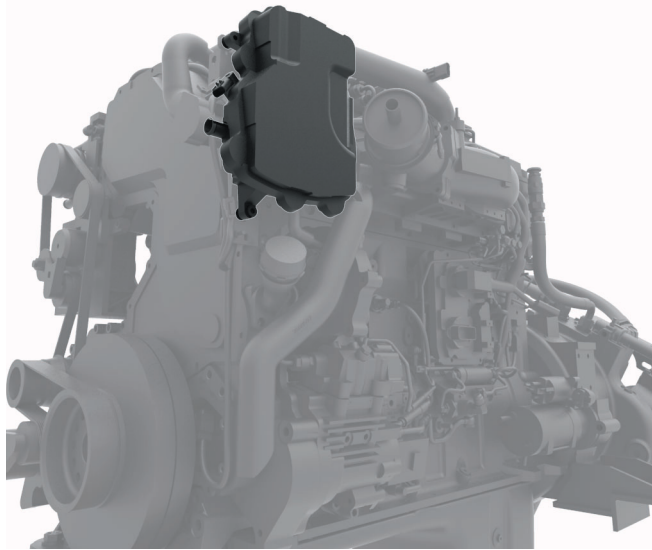

Figure 26 Crankcase Breather Element

DEF Tank Suction Filter

Service Interval: Semi-annually or every 1,000 hours, whichever occurs first.

The DEF tank is mounted on the left side of the machine. The suction filter is part of the tank head unit assembly. See Figure 27.

Service Instructions

1. Shut off engine.
2. Unplug the DEF Tank Sensor at the connector shown.
3. Open the fill cap to vent any captive pressure.
4. Remove the tank head unit assembly to inspect the suction filter at the base of the assembly.
5. If the suction filter shows any signs of damage or restriction, it must be replaced.
6. Replace the tank head unit assembly.
7. Inspect the fill neck strainer. Clean or replace as necessary.

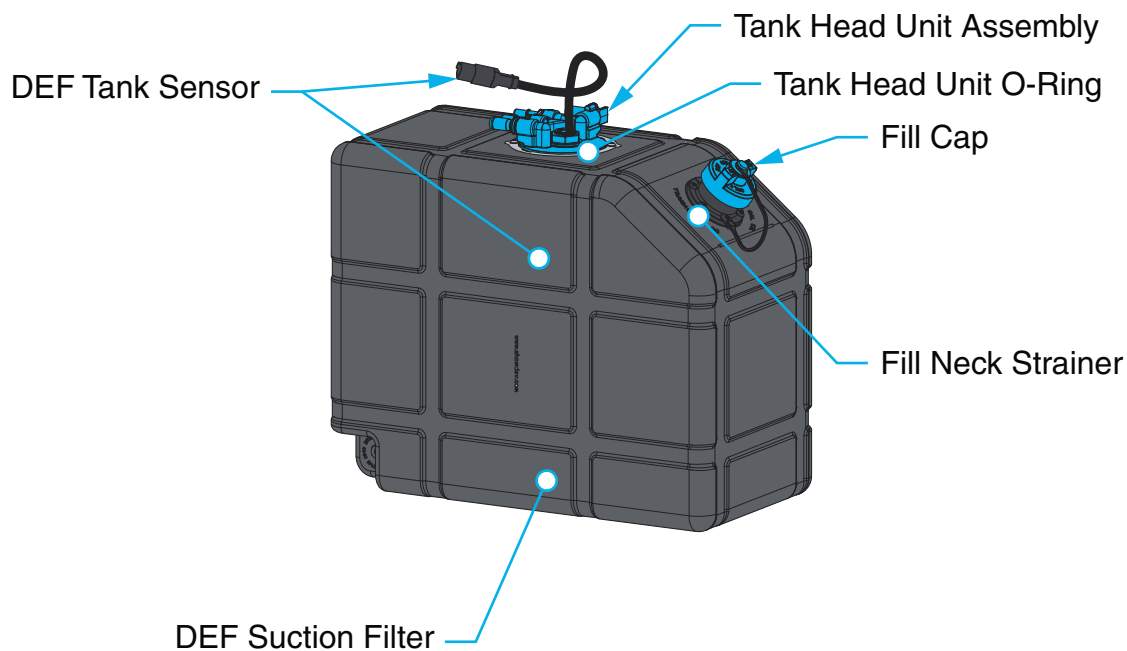

Figure 27 DEF Tank

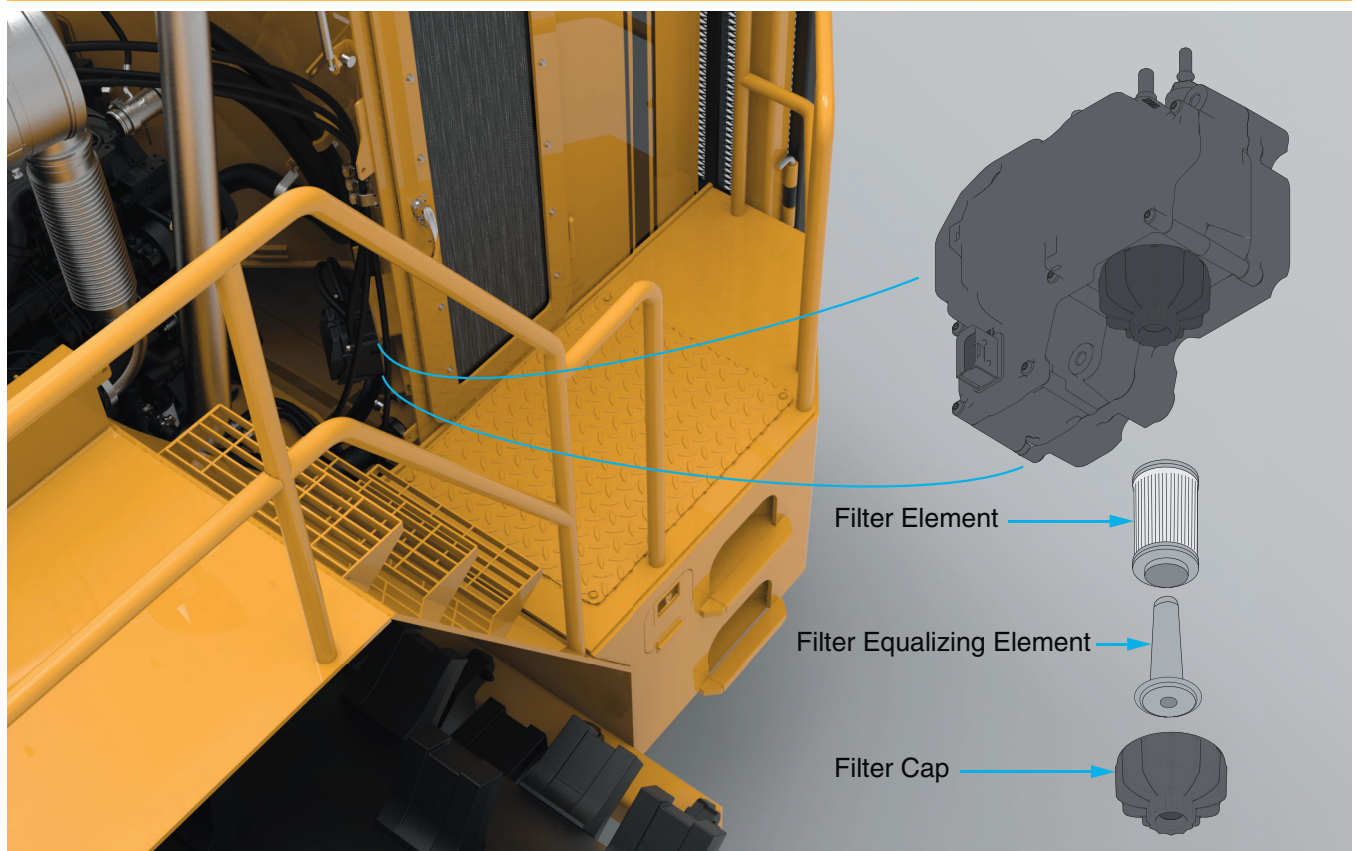

Figure 28 Aftertreatment Dosing Unit Filter

Aftertreatment Dosing Unit Filter

Service Interval: Every 3 years or every 4,500 hours, whichever occurs first.

The Aftertreatment Dosing Unit is accessed on the left side of the machine, near the engine. See Figure 28.

Consult with the Operation and Maintenance Manual supplied with your engine for servicing procedures.

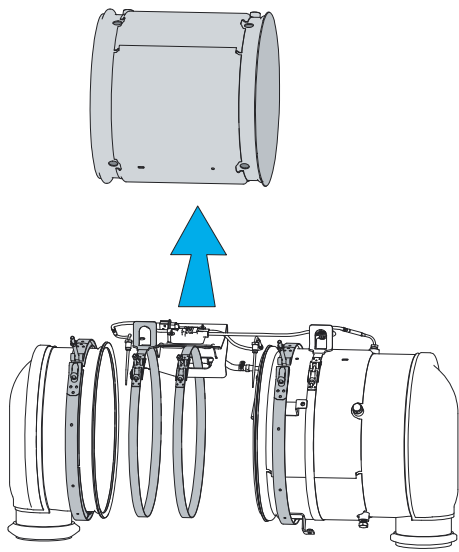

Figure 29 Detaching Diesel Particulate Filter

Diesel Particulate Filter

Service Interval: Every 4,500 hours.

The Diesel Particulate Filter (DPF) is mounted on top of the engine, left side. See Figure 30.

Service Instructions

1. Shut off engine. Allow all components to cool completely before starting work.



WARNING

Burning Hazard. The diesel particulate filter and related components external temperature may reach up to 700°C during normal operation. Extreme personal injury is possible if these components are handled while still hot. Consult the Operation and Maintenance Manual supplied with your engine for more information.

2. Remove the temperature probes in the DPF.
3. Disconnect the straps securing the DPF. See Figure 29.
4. Remove the DPF. See Figure 30.
5. Service or replace the DPF as required. Consult with your local Cummins dealer.

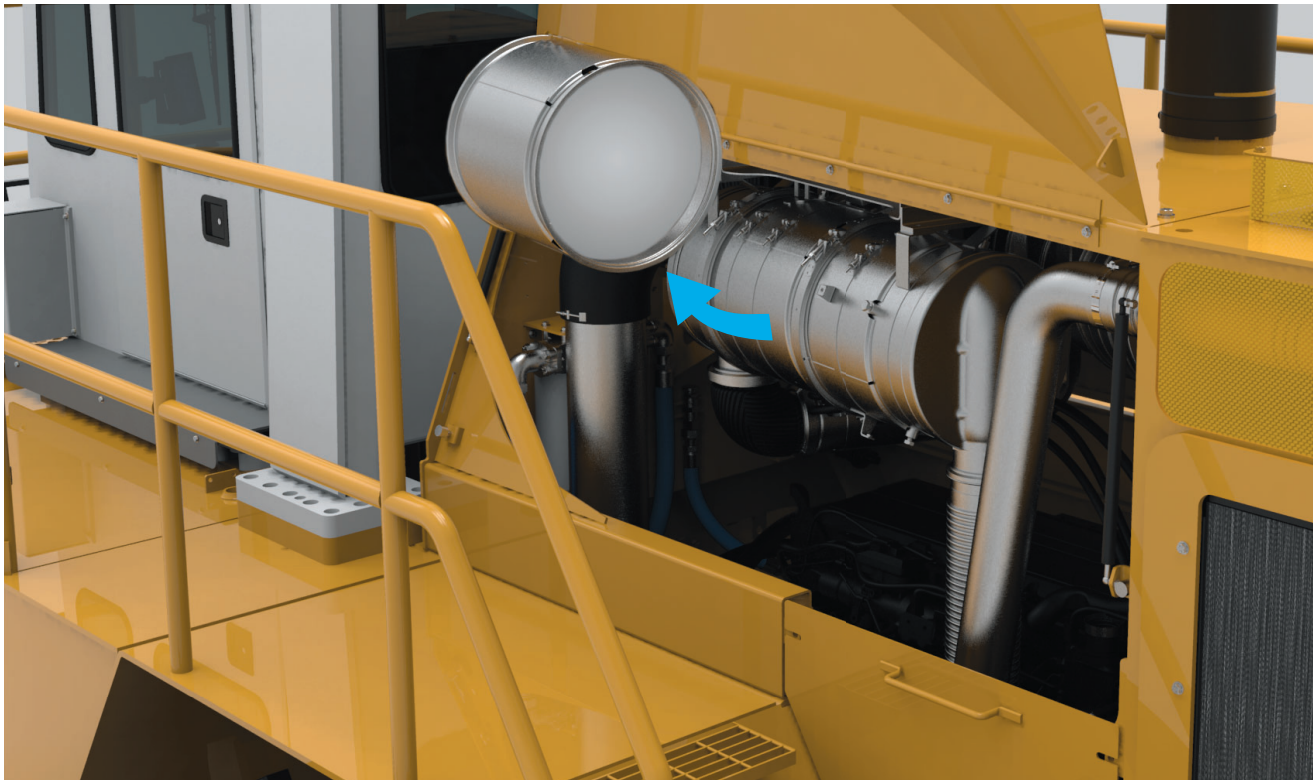

Figure 30 Removing Diesel Particulate Filter