

Filter Service

Effective filtration of fluids is vital to the longevity and performance of your Wagner. See the previous section on Preventive Maintenance for the scheduled intervals for filter element replacement where applicable.

Some filter elements (the Air Cleaner elements, for example) do not have an established service interval, but must be changed based on need. Variations in environmental conditions result in different servicing requirements.

See Figure 1 for the location of the filters on your machine. Refer to the parts manual or suggested stocking guide (SSG) for your machine for part numbers of filter elements. You should always have a full set of replacement elements in stock for your machine. Contact your dealer for details.

Refer to the following pages for timing and procedures of filter element replacement.



WARNING

Lubricating oils are extremely hot while the machine is running, and may cause severe burns or death upon contact. Shut down the machine, employ lockout/tagout procedures, allow the machine to cool and wear appropriate personal protective equipment when changing fluids or filter elements.

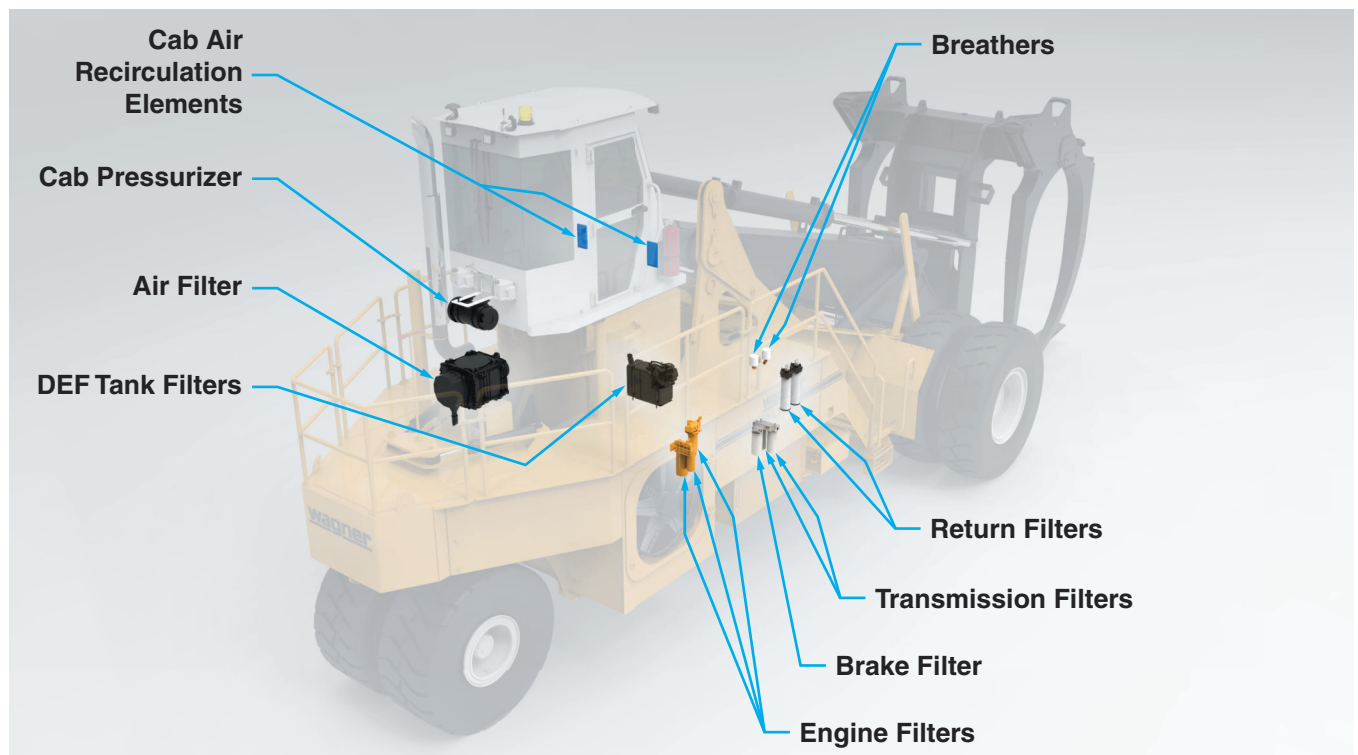

Figure 1 Filter Arrangement



Figure 2 Return Filters

Return Filters

Service Interval: Quarterly, every 500 hours, or when warning message appears, whichever occurs first.

The return filters are accessed from the deck on the right side of the machine. See Figure 2.

Allow the machine to warm up. If, after the hydraulic oil is warm, the warning message shown in Figure 3 appears on the Wagner Smart Screen Display, both filter elements must be changed before returning the machine to work, even if prior to the quarterly/500 hour interval.

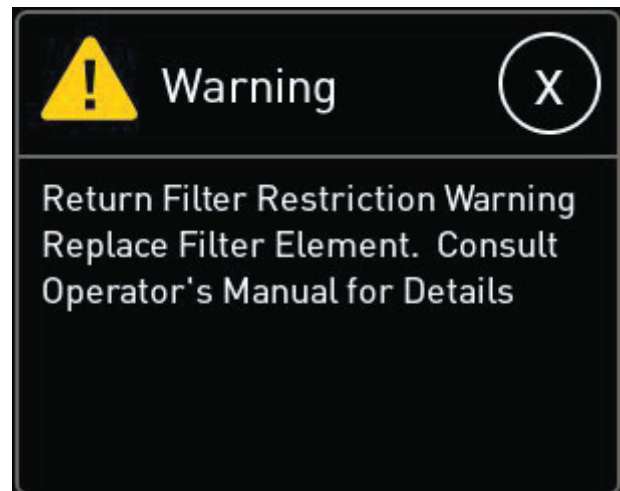

Figure 3 Return Filter Restriction Warning

Replacing the Filter Elements

1. Shut down the machine and vent captive pressure by opening the petcock at the breathers. See Figure 2.
2. Clean cover plate and surrounding area.
3. Remove cover plate and gasket.
4. Remove in-tank filter assemblies.
5. Remove contaminated cartridge with a twisting motion.
6. Discard disposable element (2).

Before Installing Cartridge

1. Check all seals and tank cover gasket and replace if necessary.

To Assemble and Install New or Cleaned Cartridge

1. Clean all components.
2. Lubricate and install all seals.
3. Insert new element.
4. Reinstall in-tank return filter into housing (make sure the top spring is secure).
5. Reinstall cover. Torque cover nuts (see 80-1057 Torque Specification Chart).
6. Close the petcock.

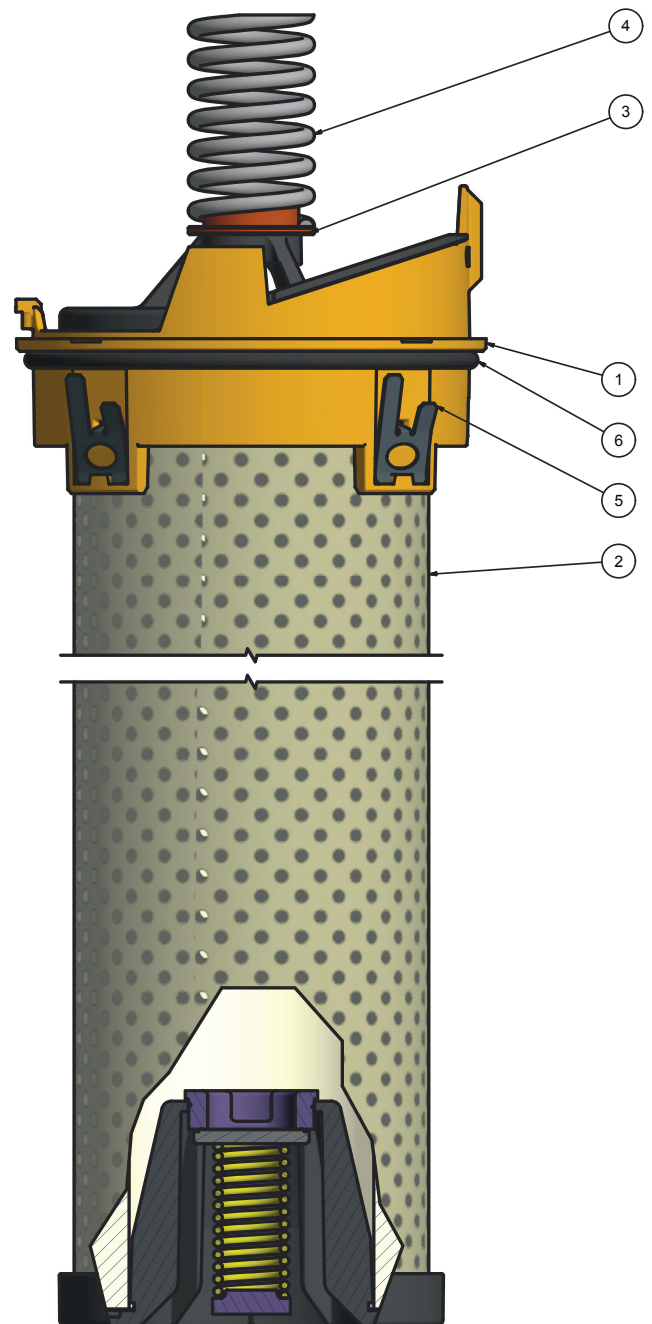

- | | |
|----------------------|-----------------|
| 1. Ring, Adapter | 4. Spring, Top |
| 2. Element, 5 Micron | 5. Clip, Spring |
| 3. Locator, Spring | 6. O-Ring |

Figure 4 Return Filter Assembly

Brake Cooling Return Filter

Service Interval: Quarterly or every 500 hours, whichever occurs first.

The brake cooling return filter is accessed on the right side of the chassis. See Figure 5.

Replacing the Filter Element

1. Shut down the machine.
2. Open vent on hydraulic tank to relieve residual pressure.
3. Clean the area around the filter element before removing.
4. Using a filter wrench, remove the brake cooling filter element and discard.
5. Clean the mating surface of the filter head before installing the new filter element.
6. Hand-tighten the filter element until it makes contact with the filter head, then an additional 1/2 turn with a filter wrench.
7. Close vent on hydraulic tank before starting vehicle.

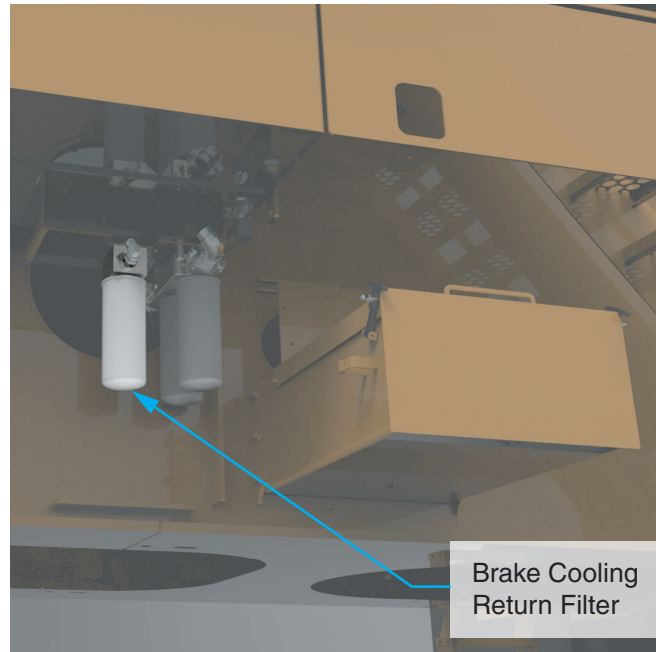

Figure 5 Brake Cooling Return Filter

Engine Filters

Engine filters include the engine oil filter, and the primary and secondary fuel filters. All are located on the right side of the chassis. See Figure 6.

Service Intervals:

Fuel Filters: Quarterly, every 500 hours, or as dictated by a fault code, whichever occurs first.

Engine Oil Filter: Quarterly, every 500 hours, or as dictated by a fault code, whichever occurs first.

The normal service intervals will be sufficient in most cases. Occasionally, the engine may throw a fault code indicating that a filter element needs to be replaced sooner. The filter element must be replaced prior to returning the machine to work, even if prior to the scheduled interval.

Refer to Section 2 of your Wagner Service Manual for the fault codes for your machine.

Refer to the Operation and Maintenance Manual supplied with your engine for filter change procedures.

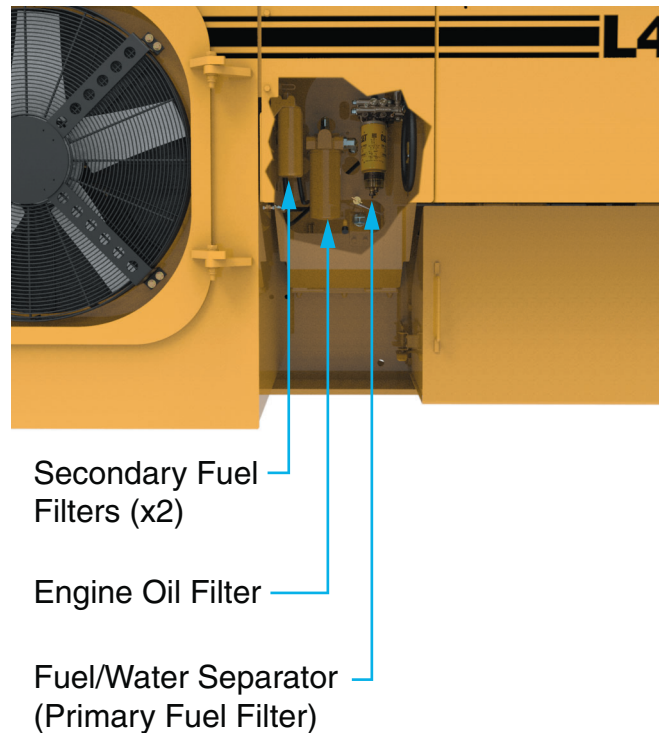

Figure 6 Engine Filters

Transmission Filters

The transmission filters are located on the right side of the chassis. See Figure 7.

Service Interval: Quarterly or every 500 hours, whichever occurs first.

Service Instructions

1. Shut down the machine.
2. Clean the area around the filter elements before removing.
3. Using a filter wrench, remove the transmission filter elements and discard.
4. Clean the mating surface of the filter head before installing the new filter elements.
5. Hand-tighten the filter element until it makes contact with the filter head, then an additional 1/2 turn with a filter wrench.

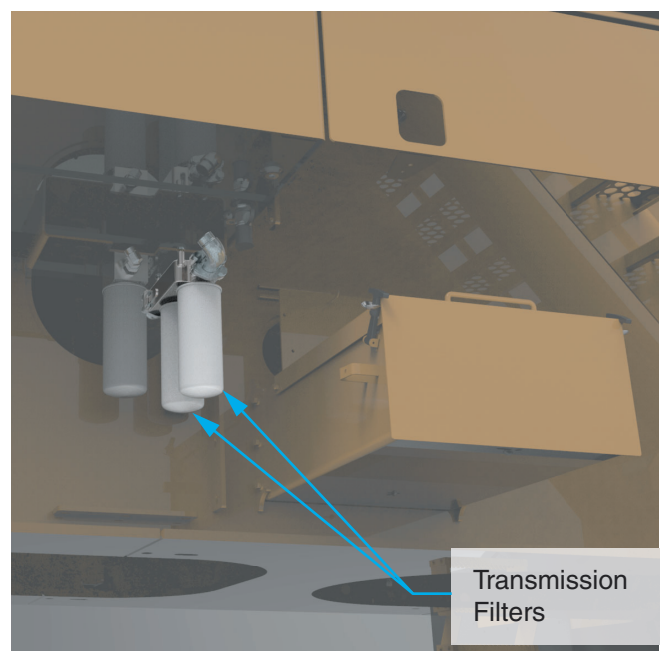

Figure 7 Transmission Filters

Air Cleaner

Service Interval: When indicator dictates.

Variations in environmental conditions do not allow for any set interval to be established for replacement of the air cleaner elements. Obviously, dustier environments will require more frequent element changes.

Therefore, the indicator must be used to determine when it's time to replace the elements. This indicator, mounted just below and to the right of the air cleaner (see Figure 8), must be checked at least once per shift, and the elements replaced as necessary.

General

The air cleaner is critical to the life of the engine. It prevents dust and debris from entering the engine air system, causing premature engine wear and possible failure.

Air Filter Service Indicator

This gauge indicates filter element condition without filter disassembly. The service sight gauge indicates filter contamination by showing "red" or "green" in the sight gauge. The visible amount of red on the indicator will increase as the dust in the element increases.

For maximum engine performance, the filter should be changed or cleaned immediately after the "red" signal locks in full view.

To reset the service gauge, press the button on the top of the gauge.



Figure 8 Air Cleaner Indicator

Air Cleaner Connections

Check the intake tubes between the air cleaner outlet and the turbocharger for cracks or wear, and that all clamps are in place and are tight.

Replace any worn or damaged tubes and tighten any loose clamps.

Service Instructions

1. Shut off engine. Unlatch the 8 metal latches around the filter service cover.



Figure 9 Unlatch 8 Places

2. Remove the filter service cover.



Figure 10 Remove Service Cover



Figure 11 Remove Primary Elements



Figure 12 Remove Secondary Elements

3. Remove the two primary filter elements. Discard in accordance with local regulations.
4. Remove the two secondary filter elements. Discard in accordance with local regulations.
5. Clean the inside of the housing with a damp cloth.
6. Replace the two secondary and two primary filter elements with new elements.
7. Replace the filter service cover and close the metal latches.

DEF Tank Filters

Service Intervals:

DEF Manifold Filter: Every 10000 hours.

DEF Fluid Filter: Every 5000 hours.

The DEF tank is mounted on the left side of the machine. The manifold filter is part of the tank head unit assembly. The fluid filter is mounted at the back of the tank. See Figure 13.

Service Instructions

Consult the Operation and Maintenance Manual for your engine for servicing instructions.

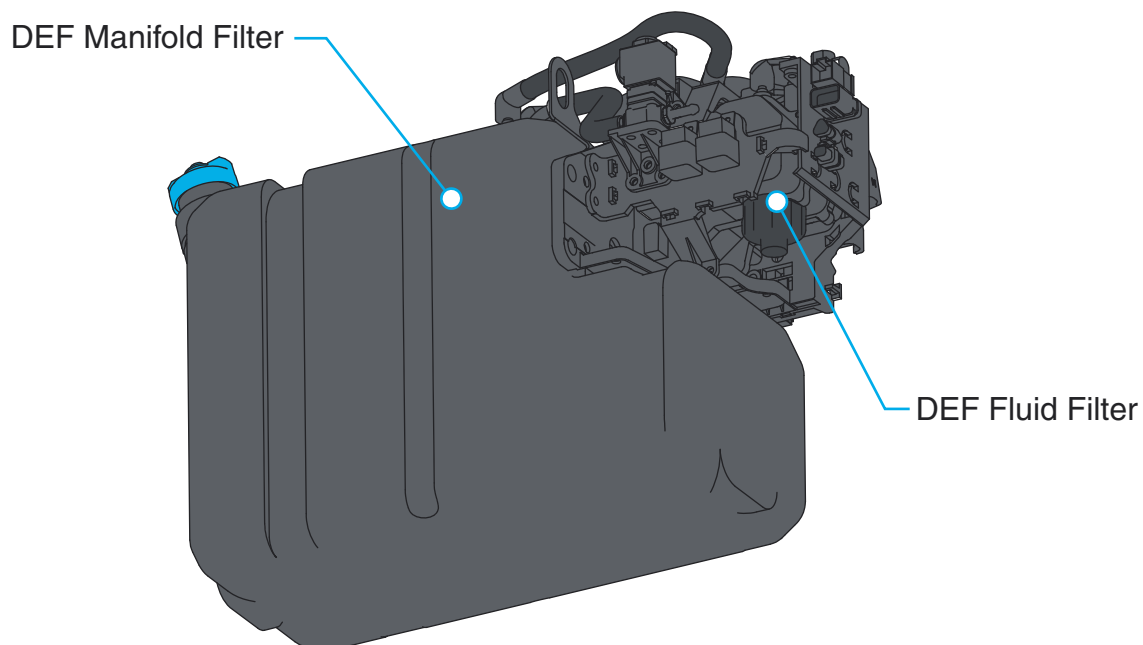

Figure 13 DEF Tank

Hydraulic Tank Breather Assemblies

The hydraulic tank breather assemblies each consist of a filter, and a check valve assembly. The check valve maintains positive pressure in the hydraulic tank (5 PSI), helping to prevent pump cavitation. Incoming air passes through the filter, keeping your hydraulic oil clean.

Periodic maintenance of the hydraulic tank breather assemblies will ensure that your hydraulic system operates at peak efficiency.

Service Interval: Every 6 months or every 1,000 hours, whichever occurs first.

Service Instructions

1. Put the machine in the normal park position (see Section 4-2).
2. Shut down the machine, and employ lockout/tagout procedures.
3. Relieve pressure in the tank by opening the petcock between the breathers. See Figure 14.
4. Using a wrench, remove the breather assemblies.
5. Remove the check valves. Discard the old filters in accordance with local regulations. See Figure 15.
6. Clean the check valves with a non-corrosive solvent.
7. Assemble the cleaned check valves with new filter elements.
8. Reinstall the breather assemblies and ensure that they operate normally during operation. Make sure the petcock is closed for normal operation.

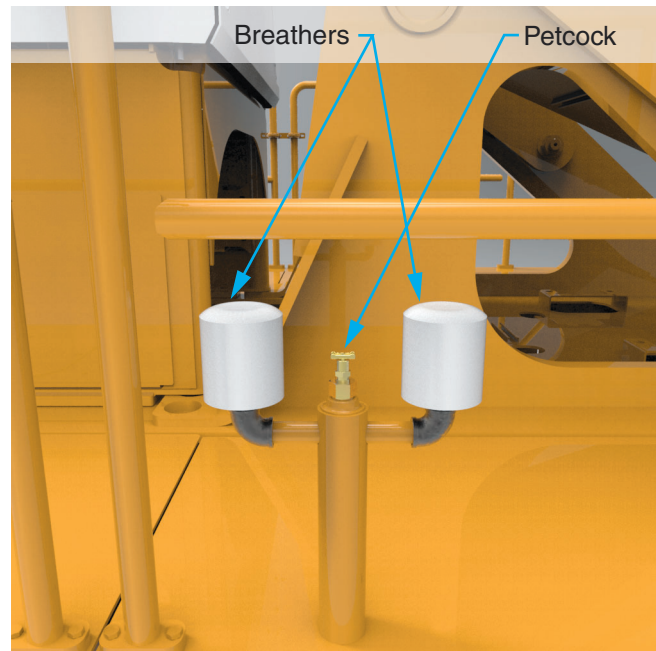

Figure 14 Hydraulic Tank Breathers

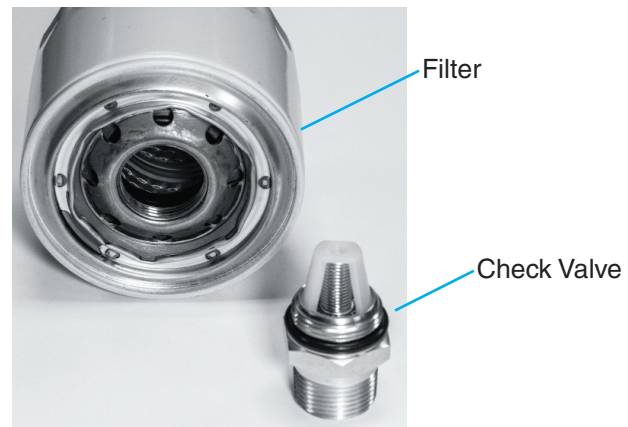

Figure 15 Breather Assembly

Cab Air Recirculation Elements

The cab air recirculation elements are located in the cab, under the dash. See Figure 16.

Service Interval: Semi-annually, every 1,000 hours, or when the cab pressurizer element is replaced, whichever occurs first.

Service Instructions

1. Shut down the machine.
2. Remove the covers.
3. Remove and discard the elements.
4. Clean the filter mounting areas.
5. Install new filter elements.
6. Install the covers.

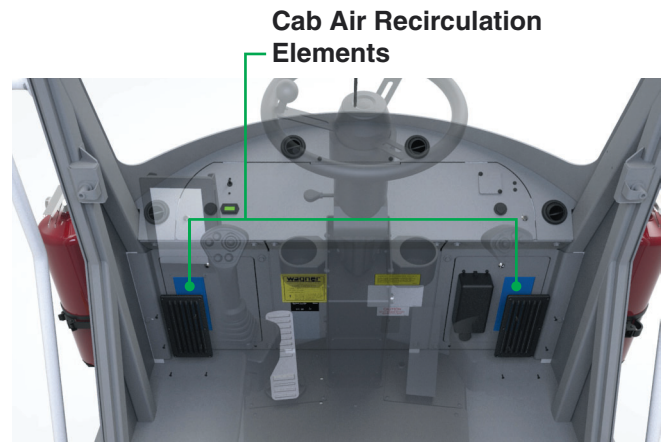

Figure 16 Cab Air Recirculation Elements

Cab Pressurizer Filter Element

The cab pressurizer is mounted to the back of the cab. See Figure 17.

Service Interval: Semi-annually, every 1,000 hours, or when a noticeable drop in cab pressure occurs, whichever occurs first.

Service Instructions

1. Work in a clean covered area to reduce operator and HVAC exposure to harmful particles.
2. Wear appropriate personal protection equipment such as gloves, mask, and coverall to protect against contaminants.
3. The machine should be off.
4. Inspect the system for any damage.
5. Release the 4 filter latches that retain the filter element noting the orientation of the ejection ports when applicable.
6. Once the filter latches are released remove the filter element. Note: Place thumbs on the exterior hardware for additional leverage when removing filter element.
7. Bag and seal used filter element and dispose of according to local regulation.
8. Inspect and remove any loose debris using a clean rag – never use compressed air.
9. Before installing the new filter, inspect for proper operation.
 - i. Turn on the system, staying clear of the open end of filter housing.
 - ii. Ensure that air is blowing out of the empty filter housing cavity.
 - iii. Turn off the system.
10. Install new filter element ensuring the ejection port orientation, when applicable, is correct and that the filter element end cap seats properly on the filter housing.
11. Restrain the filter element by reattaching the 4 filter latches.



CAUTION

When cleaning equipment, care should be taken to prevent high pressure water or High Pressure air from entering the ejection slots.

When replacing the filter, do not point ejection slots at a solid surface in close proximity to the slots.

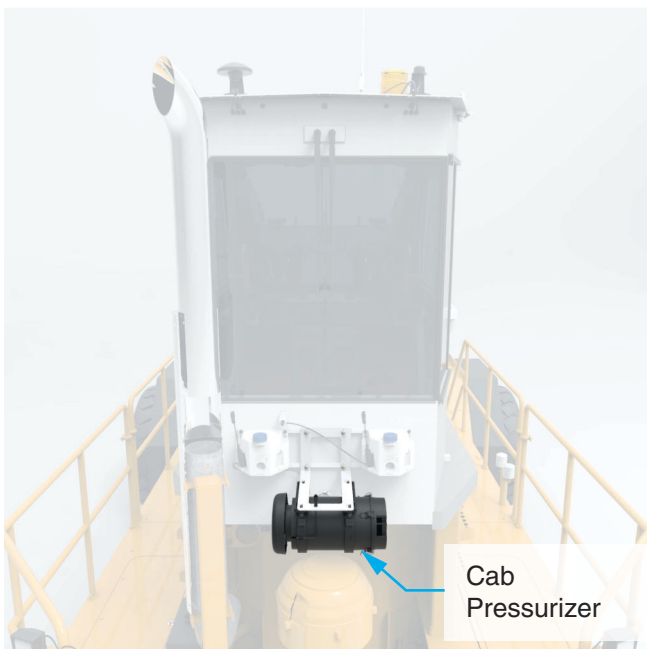

Figure 17 Cab Pressurizer

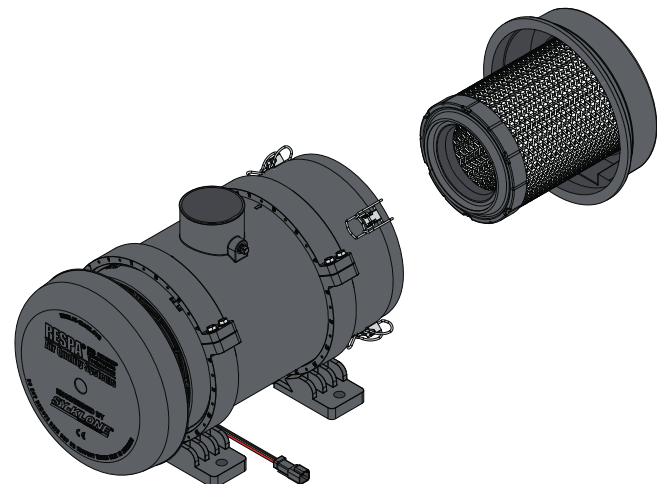

Figure 18