

Service Manual

Front Axle

Copyright ©

Kessler & Co. GmbH & Co. KG

The reproduction and distribution of this documentation in any form (photocopy, print or electronic format) is prohibited without the written approval of Kessler & Co. GmbH & Co. KG.

Hüttlinger Straße 18-20
D-73453 Abtsgmuend
Germany

Phone +49 (0) 73 66 / 81-32
Fax +49 (0) 73 66 / 81-69
service@kessler-axles.com
www.kessler-axles.com

Preface

Axles, gearboxes, drive assemblies, wheel gears, and wheel ends produced by Kessler & Co. GmbH & Co.KG (hereinafter referred to as KESSLER) are designed and produced according to the current state of the art and generally recognized safety regulations.

The following assembly instructions describe the state of the art at the time when the documentation was written. It was written to the best of the author's knowledge, KESSLER accepts no liability, however, for possible errors regarding illustrations and descriptions.

It is directly related to the corresponding installation drawing of KESSLER, which is available to the vehicle manufacturer. All technical data which has been agreed upon by the axle manufacturer and the vehicle manufacturer, and which must be observed, is specified on the installation drawing.

This documentation is not subject to revision. Subject to change without notice.

Due to the constant further development and technical improvements of our products, the illustrations may differ in the following work steps or vary from the actual product/components. Drawings, graphics, and photos are often not true to scale.

Claims for damage and consequential costs due to work carried out unprofessionally or improperly by third parties are ruled out.

Table of contents

1	Safety	1
1.1	Structure of warning notices	1
1.2	Explanation of the usual warning notices and symbols	1
1.3	Basic safety instructions	2
2	Intended use	4
3	Technical data	5
4	Transport	6
5	Installation	7
5.1	Modes of fastening and transport means	7
5.2	Measures during installation	8
5.3	Installing cardan shafts	8
6	Startup	9
6.1	Painting	9
6.2	Lines	9
6.3	Filling oil	9
6.4	Brakes	10
6.4.1	Parking brake	10
6.4.2	Wet multiple disk brake	11
6.4.3	Bleeding the wet multiple disk brake	12
6.4.4	Running-in instructions	12
6.5	Rim	13
6.5.1	Rim attachment	13
6.6	Drive flange	14
6.7	Bleeding a KESSLER-product	14
7	Checklist for the installation and startup of a KESSLER product	15
8	Operation	18
8.1	Disassembling of wheels with clamped rim fixation	18
8.2	Mounting of wheels with clamped rim fixation	19
9	Maintenance	20
9.1	Lubricants and lubrication intervals	20
9.2	Oils	21
9.2.1	Recommended types of hypoid gear oil	21
9.2.2	Approved oils for brake with external cooling	22
9.3	Oil change	23
9.3.1	Inspection of screw plugs with magnet	24

9.3.2	Oil drain	25
9.3.3	Oil filling and filling level.....	27
9.4	Checking the screwed connections, safeguards, and formation of corrosion	28
9.5	Maintenance intervals	29
9.6	Checking gaskets.....	29
9.7	Controlling of breather.....	29
9.8	Checking of the lining thickness on parking brake.....	30
9.9	Wheel bearing adjustment.....	31
9.10	Wet multiple disk brake regulations	35
9.11	Lining wear measurement of wet multiple disk brakes.....	36
9.12	Readjust the clearance	38
10	Ordering spare parts	39
10.1	Guarantee	39
10.2	Required specifications for ordering spare parts.....	39
10.3	Type plate	39
10.4	Necessary consultation with KESSLER	40
11	Storage	41
11.1	Standard conservation	41
11.2	Conditions for storage with standard conservation.....	41
11.3	Measures for longer storage periods	41
11.4	Measures before startup after storage.....	42
11.5	Responsibility during storage	42
12	Disposal.....	43
13	Important information	44
13.1	Auxiliary materials: Adhesives, sealing compounds, grease, and assembly pastes	44
13.1.1	Use of auxiliary materials.....	44
13.1.2	Handling auxiliary materials	45
13.2	Tightening torques	46
13.2.1	Tightening torque wheel nut.....	46
13.2.2	Tightening torques for standard metric threads.....	47
13.2.3	Tightening torques for metric fine threads.....	48
13.2.4	Tightening torques for galvanized screws and nuts	48
13.2.5	Tightening torque for screw plugs	49
13.3	Units.....	50
14	Supplier documents	51
14.1	Knott - FSG90, FSG110, TM6397	51

1 Safety

1.1 Structure of warning notices



SIGNAL WORD

Type and source of the danger

Consequences if ignored

➤ Measure

1.2 Explanation of the usual warning notices and symbols

DANGER



Indicates a direct danger.

If not avoided, death or serious injury will result.

WARNING



Indicates a possibly dangerous situation.

If not avoided, death or serious injury may possibly result.

CAUTION



Indicates a possibly dangerous situation.

If not avoided, injury may possibly result.

NOTICE



Indicates situations where material damage can occur.



NOTE

Indicates important information, application tips, and useful notes for proper working practices.



General warning sign that draws attention to potential dangers.



Warning against danger of burns or cut injuries.
Protective gloves must be worn.

1.3 Basic safety instructions

The following safety instructions must be read and observed before work is started on KESSLER products.

Product safety

Axles, gearboxes, drive assemblies, wheel gears, and wheel ends produced by KESSLER (referred to as KESSLER products in the following) are developed, designed and manufactured according to German and European technical regulations.

Work on Kessler products may only be carried out in compliance with the technical rules and safety regulations valid at the operating site.

- Valid health, work, and fire-protection regulations
- Laws, directives, and safety regulations

Organizational and personnel matters

Fundamental principles: axles, gearboxes, drive assemblies, wheel gears, and wheel ends produced by KESSLER may only be put into operation in a technically fault-free condition, when used as intended and being mindful of safety and danger while observing the instructions. Remove defects immediately, especially those which might adversely affect safety. The operation of defective and improperly maintained, repaired or retrofitted axles, gearboxes, drive assemblies, wheel gears and wheel ends is not permitted under any circumstances! Carry out all activities in a responsible and safety-oriented manner. Furthermore, all markings and labels on axles, gearboxes, wheel gears, and wheel ends of KESSLER must be legible.

Scope of validity: The documentation is valid for all persons who work on KESSLER products. Before work is carried out on the vehicle, the documentation must be read completely and closely observed. If there are questions or something cannot be understood, KESSLER must be consulted.

The documentation should be stored near the KESSLER products and be accessible for the personnel at any time. The documentation is part of the KESSLER products and must be available in its entirety during the entire service life.

Competences: Work on KESSLER products may only be carried out by trained technicians such as motor vehicle mechanics or persons with comparable vocational training.

Product-specific dangers

Transport, installation, maintenance, repair, and conversion work: Activities between or on moving subassemblies must be avoided as there is a danger of crushing or shearing.

The unpredictable own weight of KESSLER products or individual parts can cause them to fall or tip over unexpectedly.

- Employ only suitable, undamaged, and approved cranes and slinging means for the load in question.
- Do not stand under suspended loads.
- Secure parts with tension belts and/or suitable supports.
- Wear safety shoes.

All maintenance specifications in KESSLER's documentation must be observed.

All work must be carried out at a clean workplace.

The instructions in this documentation assume that the KESSLER product has been disassembled and is fixed onto a device for further processing. Read the vehicle manufacturer's instructions on how to dismantle the KESSLER products from the vehicle.

Work on a KESSLER product may only be carried out when permissible by the temperature of the respective component.

- Make sure that oil has cooled down before draining it.
- Make sure that rotating parts have cooled down before starting disassembly.
- Wear fire-proof gloves.

Brake: When working on the brake it must be ensured that no unintended machine movement can occur when the brake mechanism is disengaged.

The brake is a safety component of the first order; improper work on it may cause the brake to fail.

Rim and tire: Never stand directly in front of the rim when air is released or during inflation. Parts may suddenly come loose and be ejected due to the inner pressure of the tire.

The air needs to be released completely from the tire beforehand when disassembling versions with clamped rim fixation. Be sure to observe the tightening torques and maintenance of the wheel nuts and clamps.

Lubricants and auxiliary materials: Be sure to observe the manufacturer's safety data sheets when handling lubricants and auxiliary materials (e.g. oils and greases).

Oils and greases can trigger allergic reactions on skin. For this reason, appropriate protective clothing must be worn.

Loose-fitting clothing and long loose hair is prohibited when working on KESSLER products!

When metal parts are being machined where there is a risk of shattering (grinding, deburring, cleaning with compressed air, etc.), bits of metal may be flung out that can injure the eyes. For this reason, safety goggles must always be worn.

KESSLER offers customer service tools that make working on axles, gearboxes, wheel gears, and wheel ends easier and safer.

Repair welding is only permitted after consultation with KESSLER!

Before reassembling used parts, they must be checked for damage, fault-free contact surfaces and wear. In particular, check that there are no chips or other foreign bodies in the axles, gearboxes, wheel gears, and wheel ends.

After carrying out maintenance and repair work, check that the product functions properly.

2 Intended use

KESSLER axles, wheel gears, wheel ends, drive assemblies or gearboxes may only be installed and operated in vehicles for which they have been designed. KESSLER products may not be operated when they have been dismantled.

3 Technical data

All technical data is specified on the corresponding installation drawing of KESSLER and is available to the vehicle manufacturer. The installation drawing provides information on the following points:

- Installation dimensions
- Direction of travel
- Location of the connections
- Permitted operating pressures, etc.

4 Transport

WARNING



Own weight / gravity of axles, gearboxes, wheel gears, or wheel ends is not observed or underestimated.

Risk of injury

- Use only hoisting devices and slinging means with sufficient lifting capacity.
- Employ suitable, undamaged, and approved cranes for the load in question.
- Do not stand under suspended loads.

- A KESSLER product is generally prepared by KESSLER, securely placed on a transport frame for transport.
- The shipping company has to secure the shipment onto the vehicle.
- Each KESSLER product should be transported in such a manner as to avoid any damage.
- Keep the weight of the KESSLER product to be transported in mind; refer to the valid transport papers.
- Secure top-heavy KESSLER products on the industrial truck so that it does not tip over.
- Always fasten and secure the KESSLER product at a minimum of two points.

5 Installation

⚠ WARNING



Falling, slipping, tipping of axles, gearboxes, wheel gears, or wheel ends during installation

Risk of injury

- Securing components with tension belts and/or supports
- Employ only suitable, undamaged, and approved cranes and slinging means for the load in question.

⚠ CAUTION



Sharp-edged parts

Danger of cut injuries

- Wear protective gloves.

5.1 Modes of fastening and transport means

- A KESSLER product is generally securely placed on a transport frame for shipment. To lift and move a KESSLER product, a traverse is needed as well as hoisting devices and slinging means with sufficient lifting capacity.
- Fasteners for the installation of the KESSLER product may only be attached to steelwork components that have the appropriate capacity for the load. If you have any questions, please contact KESSLER.
- A gearbox may only be loaded at the support or attachment points provided. Under no circumstances use control cylinders, pipes or similar parts for suspension.
- Drive assembly may only be loaded at the support or attachment points provided or the housing of the drive assembly must be secured with a round sling with sufficient capacity. Under no circumstances use control cylinders or similar parts for suspension.
- The KESSLER product always has to be fastened and secured at a minimum of two points.
- Releasing the hoisting devices and slinging means is only permitted once the KESSLER product has been sufficiently attached to the vehicle.

5.2 Measures during installation

- The vehicle manufacturer must make sure that there is sufficient means for raising and supporting the KESSLER product during installation.
- The vehicle manufacturer must make sure that no persons are present in the danger zone during the lifting.
- The vehicle manufacturer must make sure that the KESSLER product cannot move uncontrolled during/after the installation.
- Wear work gloves during the installation.
- Use suitable tools during the installation.

5.3 Installing cardan shafts

- When installing cardan shafts, the phasing (Z- or W-alignment) allowed for and the specified deflection angles must be maintained.

6 Startup

6.1 Painting

- When painting the KESSLER product, the radial seal rings must be protected from paint.

6.2 Lines

- Connect lines only when they are not pressurized.

6.3 Filling oil

- KESSLER products are generally shipped without oil; they therefore need to be filled with oil.
- Always check the oil filling before startup, even if a KESSLER product was delivered with an oil filling as ordered.
- Make sure the correct oil quality is used for filling, [see "Oils" on page 21.](#)
- Check the oil level, [see "Oil change" on page 23.](#)
- Take separate oil spaces and pre-filling into account, e.g. at drop gear and through drive assembly or at gear boxes assembled onto axles.

Oil quality for wet multiple disk brake with external cooling

- Make sure the correct oil quality is used for filling, [see "Approved oils for brake with external cooling" on page 22.](#)

6.4 Brakes

⚠ DANGER	
	<p>Brake failure due to ignoring of regulations during startup.</p> <p>Serious injury</p> <ul style="list-style-type: none"> ➤ When working on the brakes, make sure that no unintended vehicle movement can occur when the brake mechanism is disengaged. ➤ The vehicle manufacturer has to carry out a documented brake test before releasing the vehicle.

- Use specified actuation medium, see installation drawing as well as the brake manufacturer's instructions.
- Observe the permissible maximum actuation pressures according to the installation drawing, brake calculation, brake specification sheets or the brake manufacturer's instructions.
- Check that the position of the brake connections is correct according to the installation drawing.
- Bleed the actuation space / piston space of the brakes, see respective instructions of the brake manufacturer.
- Check the proper function of the brakes.
- On combination operational and parking brakes, an overload of brake components needs to be prevented during joint actuation of the operational and parking brake by installing a suitable protection valve.
- The vehicle manufacturer must observe the running-in instructions of the brake manufacturer and KESSLER.
- The vehicle manufacturer has to carry out a documented brake test before final startup of the vehicle.



6.4.1 Parking brake

⚠ DANGER	
	<p>Parking brake is under spring tension. Parts may suddenly come loose and be ejected when the parking brake is opened improperly.</p> <p>Risk of injury</p> <ul style="list-style-type: none"> ➤ The supplier's assembly and disassembly sequence and repair instructions must be observed.

⚠ CAUTION	
	<p>The clearance at the brake needs to be adjusted; parts of the brake are moved thereby.</p> <p>Danger of being crushed</p> <ul style="list-style-type: none"> ➤ Take hold of the brake by hand only from the outside.

- After the installation, adjust the clearance; observe the procedure according to the instructions of the brake manufacturer, see ["Supplier documents" on page 51.](#)
- Bleed the parking brake; observe the procedure according to the instructions of the brake manufacturer for this, see ["Supplier documents" on page 51.](#)

6.4.2 Wet multiple disk brake

 DANGER	
	<p>Brakes with spring applied elements are under very high spring tensions.</p> <p>Parts may suddenly come loose and be ejected when working on these subassemblies.</p> <ul style="list-style-type: none"> ➤ Opening of the brakes is prohibited. ➤ In case it becomes necessary to open brakes, the respective safety and repair instructions of KESSLER must be observed.

Brake cooling



- Observe the position of the connections, in particular the cooling oil connections, see installation drawing / ["Technical data" on page 5.](#)
- External cooling of the wet multiple disk brake is necessary. A model without cooling is only permissible with the express approval of KESSLER.
- Approved oils for cooling (attention: observe LS additives) see KESSLER company standard WN85601 and WN85602.
- The amount of cooling oil needs to be specified according to vehicle usage. Representative test drives with the vehicle are necessary to verify sufficient cooling.
- The cooling oil pressure at the cooling oil outlet must not exceed 1 bar. Pressures up to 5 bar are permissible at the cooling oil inlet however.
- The cooling oil temperature at the cooling oil outlet must not exceed 100°C. The cooling oil temperature at the cooling oil inlet must therefore not exceed 70°C.
- The cooling oil circuit should be designed with a tank that allows for a dewatering of the oil. Water in the oil can cause the brake linings to come loose!

Brake actuation

- Observe the respective brake specifications sheet WN 63.... according to the technical specification field on the installation drawing / ["Technical data" on page 5.](#)
- Approved oils for actuation; see KESSLER company standard WN85601 and WN85602. Use only mineral oils!
- Check the permissible maximum residual pressure in non-actuated condition according to brake specifications sheet!
- Constant pressure at the brake actuation is not permissible!

6.4.3 Bleeding the wet multiple disk brake

The brake system needs to be bled before starting up the vehicle.

⚠ WARNING	
	<p>When work is being performed on the brake, its braking effect is disabled.</p> <p>Rolling away of the vehicle</p> <ul style="list-style-type: none"> ➤ Make sure that no machine movements can take place.
⚠ CAUTION	
	<p>Oil and bleeder valve are pressurized.</p> <p>Injury due to parts being ejected</p> <ul style="list-style-type: none"> ➤ Only trained technicians may bleed the brakes.

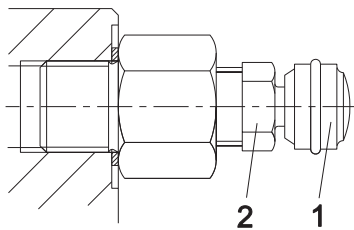

1. Make sure that no machine movements can take place.
2. Pressurize the brake.
 - The brake closes.
3. Remove the protection cap (1) of the bleeder valve (2).
4. Slide the hose onto the bleeder valve.
5. Open the bleeder valve slowly by no more than 1/4 of a rotation.
 - Oil-air mixture escapes through the hose.
6. Once only oil seeps out, close the bleeder valve again properly.
7. Pull off the hose.
8. Place the protection cap (1) onto the bleeder valve (2).

6.4.4 Running-in instructions

Running-in instructions for wet multiple disk brakes:

- When starting up the vehicle, drive carefully to bring the brakes to the operational temperature.
- Drive carefully to get used to the brake effect.

6.5 Rim

- Check permissible rim offset according to the installation drawing / ["Technical data" on page 5](#).
- Contact surface for rim and fastening parts of the rim have to be level, clean and free of grease.
- Check the clearance between rim and tire to the neighboring axle parts.
- On steerable axles, check the clearance, in particular at full steering angle.

6.5.1 Rim attachment

Stud / Wheel Bolts

- Use correct types of studs/wheel bolts, screw into the wheel hub as far as it will go .

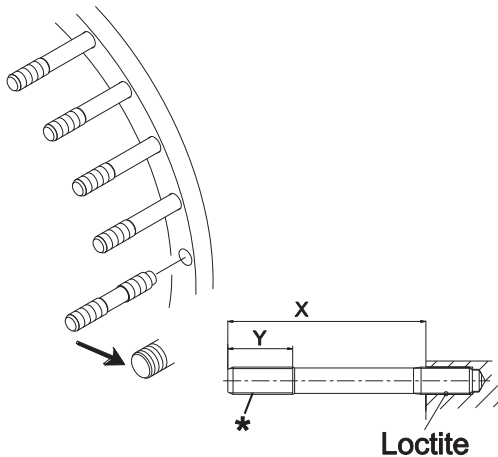

1. Pick up the cleaned studs/wheel bolts screw in.
 - * = Thread M22x1.5
 - Check dimension Y and X according to the installation drawing ["Technical data" on page 5](#).
 - The threads of the studs must not be lubricated!
 - Loctite 262
 - Tightening torque: 150 Nm

Wheel nut with clamp - clamped rim fixation

⚠ DANGER



When disassembling and mounting wheels on vehicles with clamped rim fixation, damaged parts of the rim may suddenly be ejected explosively due to the tire pressure when loosening the clamped rim fixation.

Serious or fatal injuries of the mechanic

- Release the air in the tire completely before carrying out any work.
- Never stand directly in front of the rim when air is released or while pumping air.

⚠ WARNING



After the assembly and during operation, the clamped rim clamping unit may settle.

If the wheel nuts are not tightened properly, the rim screw connection loosens and also the wheel.

- Retighten the wheel nuts regularly after a few operating hours until no settling occurs anymore.

The following list serves only as an overview of the steps that must be observed to fasten the clamped rim.

- Clean the rim carefully and check for possible cracks or defects.
 - A damaged rim must not be reused!
- Check that tires are of the intended type and show no bulges or cracks.
- Clean the retaining nuts.
 - The threads of the retaining nuts must not be lubricated!
- Check if the wheels are in full contact with the contact surface of the wheel hub.
- Position the clamping plates and tighten the retaining nuts cross-wise.
 - Use only nuts of the specified type!
 - Tightening torque: [see "Tightening torque wheel nut" on page 46](#)
- Inflate tires.
 - Tire pressure: refer to vehicle manufacturer's specifications

6.6 Drive flange

- Contact surfaces have to be clean and free of grease.
- Observe the reduced tightening torque for galvanized screws, [see "Tightening torques" on page 46](#)

6.7 Bleeding a KESSLER-product

At oil filled KESSLER-products breather are usually delivered separately.

- Mount breather, screw in the breather and tighten it hand-tight .
- Check breather for correct function.
- Check if the breather is free of damage, paint and dirt.
- A leaky breather must be replaced.

7 Checklist for the installation and startup of a KESSLER product

For safety instructions and required work/tasks, refer to the chapter Installation and startup.	Completed		
Items to be checked:	yes	no	Remarks

For safety instructions and required work/tasks, refer to the chapter Installation and startup.	Completed		Remarks
	yes	no	
Items to be checked:			
Installing a KESSLER product after a longer storage period			
<ul style="list-style-type: none"> Special measures observed before startup after storage? 	<input type="checkbox"/>	<input type="checkbox"/>	
Moving KESSLER product			
<ul style="list-style-type: none"> Capacity of the hoisting device and the slinging means sufficient for the KESSLER product? Is the KESSLER product to be moved secured at two steelwork components (suitable for the load)? 	<input type="checkbox"/> <input type="checkbox"/>	<input type="checkbox"/> <input type="checkbox"/>	
Installation position			
<ul style="list-style-type: none"> Driving direction and installation angle observed? 	<input type="checkbox"/>	<input type="checkbox"/>	
Lines			
<ul style="list-style-type: none"> All lines connected? 	<input type="checkbox"/>	<input type="checkbox"/>	
Rim			
<ul style="list-style-type: none"> Permissible rim offset checked according to the installation drawing? Clearance between rim and neighboring axle parts checked? 	<input type="checkbox"/> <input type="checkbox"/>	<input type="checkbox"/> <input type="checkbox"/>	
Rim attachment			
<ul style="list-style-type: none"> Is the contact surface for rim and fastening parts of the rim to be level, clean and free of grease? Correct fastening parts used? Fastening parts tightened with the correct tightening torque? Retighten the fastening parts regularly after short running interval! 	<input type="checkbox"/> <input type="checkbox"/> <input type="checkbox"/> <input type="checkbox"/>	<input type="checkbox"/> <input type="checkbox"/> <input type="checkbox"/> <input type="checkbox"/>	
Tires			
<ul style="list-style-type: none"> Clearance between tires and neighboring axle parts checked? Tire pressure correct according to vehicle manufacturer's specifications? 	<input type="checkbox"/> <input type="checkbox"/>	<input type="checkbox"/> <input type="checkbox"/>	
Inlet direction of rotation / driving direction correct?	<input type="checkbox"/>	<input type="checkbox"/>	
Radial seal rings			
<ul style="list-style-type: none"> Radial seal rings free of paint? 	<input type="checkbox"/>	<input type="checkbox"/>	
Oil filling			
<ul style="list-style-type: none"> Oil quality used correct? KESSLER product filled to correct oil level? Separate oil spaces (drop gear and through drive assemblies, 	<input type="checkbox"/> <input type="checkbox"/>	<input type="checkbox"/> <input type="checkbox"/>	



For safety instructions and required work/tasks, refer to the chapter Installation and startup.	Completed		
Items to be checked:	yes	no	Remarks
...) filled? • Recheck oil level short time after startup!	<input type="checkbox"/> <input type="checkbox"/>	<input type="checkbox"/> <input type="checkbox"/>	
Brakes <ul style="list-style-type: none"> • Actuation medium correct? • Actuation pressure checked? • Max. permissible residual pressure checked? • Brake properly connected? • Cooling oil medium of the brake correct? • Actuation space, piston space of the brake bled? • Function tested? • Running-in instructions observed? • Brake test carried out? 	<input type="checkbox"/> <input type="checkbox"/> <input type="checkbox"/> <input type="checkbox"/> <input type="checkbox"/> <input type="checkbox"/> <input type="checkbox"/> <input type="checkbox"/> <input type="checkbox"/>	<input type="checkbox"/> <input type="checkbox"/> <input type="checkbox"/> <input type="checkbox"/> <input type="checkbox"/> <input type="checkbox"/> <input type="checkbox"/> <input type="checkbox"/> <input type="checkbox"/>	
Parking brake <ul style="list-style-type: none"> • Clearance set? • Brake bled? 	<input type="checkbox"/> <input type="checkbox"/>	<input type="checkbox"/> <input type="checkbox"/>	
Drive flange <ul style="list-style-type: none"> • Contact surfaces clean and free of grease? • Screw connections tightened with the correct tightening torque? 	<input type="checkbox"/> <input type="checkbox"/>	<input type="checkbox"/> <input type="checkbox"/>	
Cardan shaft <ul style="list-style-type: none"> • Phasing and deflection angles correct? 	<input type="checkbox"/>	<input type="checkbox"/>	
Breather <ul style="list-style-type: none"> • Breather mounted and checked? 	<input type="checkbox"/>	<input type="checkbox"/>	

8 Operation

The technical specifications such as the permissible axle load must be observed at all times when KESSLER products are operated.

Refer to the installation drawing / ["Technical data" on page 5](#).

8.1 Disassembling of wheels with clamped rim fixation

 DANGER	
	<p>When disassembling and mounting wheels on vehicles with clamped rim fixation, damaged parts of the rim may suddenly be ejected explosively due to the tire pressure when loosening the clamped rim fixation.</p> <p>Serious or fatal injuries of the mechanic</p> <ul style="list-style-type: none">➤ Release the air in the tire completely before carrying out any work.➤ Never stand directly in front of the rim when air is released or while pumping air.



When removing and mounting wheels with clamped rim fixation, the specifications of the vehicle manufacturer must be strictly observed!

The following list serves only as an overview of the steps that must be observed before starting to repair the axle.

- Engage parking brake.
- Secure vehicle to prevent it from rolling away.
- Raise the axle using a suitable hoisting device and slinging means until the wheel is completely off the ground.
- Secure axle against falling down.
- Release the air in the tire according to the vehicle manufacturer's specifications.
- Secure the wheel with a suitable hoisting device.
- Loosen the nuts along with the clamping plates and remove the wheel.
- Secure wheel to prevent it from rolling away and tipping over.

8.2 Mounting of wheels with clamped rim fixation

DANGER



When disassembling and mounting wheels on vehicles with clamped rim fixation, damaged parts of the rim may suddenly be ejected explosively due to the tire pressure when loosening the clamped rim fixation.

Serious or fatal injuries of the mechanic

- Release the air in the tire completely before carrying out any work.
- Never stand directly in front of the rim when air is released or while pumping air.

WARNING



After the assembly and during operation, the clamped rim clamping unit may settle.

If the wheel nuts are not tightened properly, the rim screw connection loosens and also the wheel.

- Retighten the wheel nuts regularly after a few operating hours until no settling occurs anymore.



When removing and mounting wheels with clamped rim fixation, the specifications of the vehicle manufacturer must be strictly observed!

The following list serves only as an overview of the steps that must be observed to fasten the clamped rim.

- Clean the rim carefully and check for possible cracks or defects.
 - A damaged rim must not be reused!
- Check that tires are of the intended type and show no bulges or cracks.
- Clean the retaining nuts.
 - The threads of the retaining nuts must not be lubricated!
- Check if the wheels are in full contact with the contact surface of the wheel hub.
- Position the clamping plates and tighten the retaining nuts cross-wise.
 - Use only nuts of the specified type!
 - Tightening torque: [see "Tightening torque wheel nut" on page 46](#)
- Inflate tires.
 - Tire pressure: refer to vehicle manufacturer's specifications

9 Maintenance

9.1 Lubricants and lubrication intervals

Lube point	Lubricant	Remarks	Lubrication intervals (The value that is reached first is always valid.)			
			after 100 hours of-operation 1000 km	every 500 hours of-operation 5000 km	every 1000 hours of-operation 10,000 km	at least 1 x per year
Differential and carrier assembly	Hypoid gear oil acc. to MIL-L2105 B/API GL5	Oil change monthly oil level check by overflow measurement	+		+	+
Wheel hub – planetary gear	Hypoid gear oil in multi-grade characteristic acc. to MIL-L2105 C/D/API GL5		+		+	+
Interaxle differential	SAE 90 o. multi-grade oils with normal outdoor temperatures		+		+	+
Drop gear assembly / Gearbox	SAE 75 W - 90; SAE 75 W - 85 at outdoor temperatures under -10 °C		+		+	+
Wheel bearing oil-lubricated	SAE 140 o. multi-grade oils with outdoor temperatures over +30 °C		+		+	+
Wet multiple disk brake	see " Approved oils for brake with external cooling " on page 22	with external cooling: Oil change	depends on tank volume / cooling system / application			

9.2 Oils

9.2.1 Recommended types of hypoid gear oil



For KESSLER axles, gear oil types with the specification MIL-L 2105 B/API GL 5 or MIL-L 2105 C/D/API GL 5 have to be used!

- ADDINOL - gear oil GH 85 W 90
- AGIP - Rotra MP / Rotra MP DB
- ARAL - gear oil Hyp 90
- AVIA - gear oil Hypoid 90 EP
- BP - multipurpose gear oil EP SAE 90
- ELF - Tranself type B 90 / Tranself type B 80 W - 90
- ESSO - gear oil GX - D 90
- FINA - Pontonic MP SAE 85 W - 90
- FUCHS - Renogear Hypoid 90
- MOBIL - HD 90 - A
- SHELL - Spirax MB 90 / HD 90
- TEXACO - Multigear EP SAE 85 W / 90

9.2.2 Approved oils for brake with external cooling

Actuation fluid:

NOTICE	
	<p>Use only mineral oil as actuation fluid. Brake fluids are not permitted!</p>

Selection of mineral oils:

- Motor oil
 - API SE / CD
 - MIL – L 46152C / MIL – L 2104 C or D
- AFT C - 3 or Dexron ®
- Hydraulic oil HLP DIN 51524 part 2

Viscosity class depending on ambient temperature:

- for temperate climate: ISO VG 22 – 32
- for extremely cold climate: ISO VG 15
- for extremely warm climate: ISO VG 46

Cooling fluid:

NOTICE	
	<p>Only oils with LS additives that are approved by the vehicle manufacturer according to the KESSLER WN 85601 may be used.</p> <p>➤ e.g. 3 - 6% Lubrizol LZ 9990 A or LZ 6279</p>

The cooling fluid can also be used as actuation fluid.

9.3 Oil change

During changing the oil, always follow the stated measures:

- Place vehicle in horizontal position so that complete draining of oil is possible and clean oil can be filled to the correct level.
- Make sure that oil has cooled down before draining it.
- Always replace gaskets of the screw plugs with new gaskets. The gaskets are mostly copper rings.
- Pay attention to the specific notes.
- The precise position of the lube point can deviate from the illustration. The relevant lube point can be found on the KESSLER product on hand.
- Pay attention to the given activity sequence.

9.3.1 Inspection of screw plugs with magnet

Each oil change requires a check of the magnetic screw plugs. After opening the oil drain plug, the adherent material must be assessed and acted on the information listed below.

During the first operating hours, a larger build-up of metal particles is normal for reasons of the running-in period of new parts. The information below is valid from the 3rd oil change.



Rating 1

Black mud/paste - fine, not shining metallic powder without chips and metal fractions

- Normal wear
- No indication of a problem
- Clean magnet / continue oil change / component can return to operation



Rating 2

Fine chips and coarser metallic powder - slightly shiny

- Check the wheel bearing for play
- A close monitoring with regular oil change is necessary
- Optionally determine the trend with oil analyses
- Clean magnet / oil change is absolutely necessary



Rating 3

Larger shiny chips and splitters

- Check the bearings and gear parts for damages
- Check the parts before continue operation

9.3.2 Oil drain

⚠ CAUTION**Hot oil**

Burn hazard

- Make sure that oil has cooled down before draining it.

**Differential and carrier assembly, axle housing and hub assembly have a total oil space.**

Oil drain has to take place at the complete axle.

**Wet multiple disk brake**

Drain the extra oil.

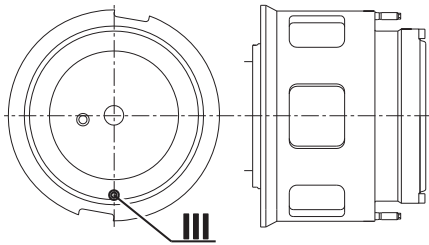
III = oil drain point**Oil drain, hub assembly:**

1. Clean drainage point and oil drain plug.
2. Rotate the hub assembly until the oil drain plug is at the bottom position (6 o'clock position).
3. Open the oil drain plug and allow oil to drain.
 - Collect the oil in a suitable container.
 - Dispose of the oil in an environmentally friendly manner.
4. Clean borehole and oil drain plug.
5. Screw oil drain plug back in.
 - Tightening torque: [see " Tightening torque for screw plugs" on page 49](#)

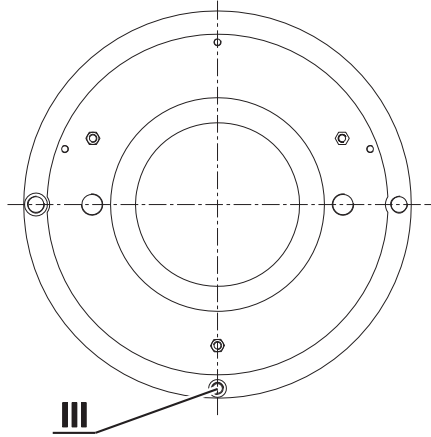
**Oil drain, wet multiple disk brake:**

1. Clean drainage point and oil drain plug.
2. Open the oil drain plug and allow oil to drain.
 - Collect the oil in a suitable container.
 - Dispose of the oil in an environmentally friendly manner.
3. Clean borehole and oil drain plug.
4. Screw oil drain plug back in.
 - Tightening torque: [see " Tightening torque for screw plugs" on page 49](#)

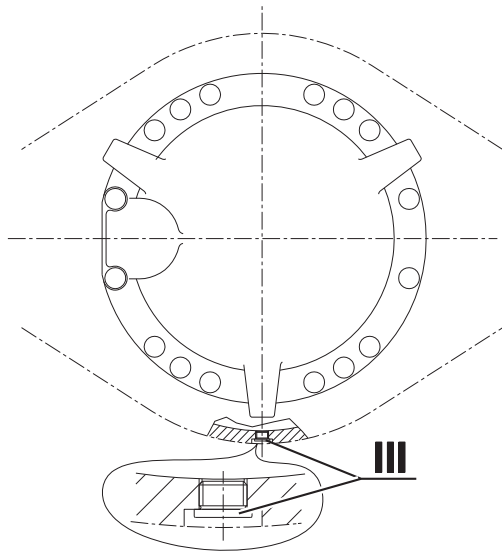
**Oil drain, differential and carrier assembly/axle housing:**

1. Clean drainage point and oil drain plug.
2. Open the oil drain plug and allow oil to drain.
 - Collect the oil in a suitable container.
 - Dispose of the oil in an environmentally friendly manner.
3. Clean borehole and oil drain plug.
4. Screw oil drain plug back in.
 - Tightening torque: [see " Tightening torque for screw plugs" on page 49](#)

9.3.3 Oil filling and filling level



Differential and carrier assembly, axle housing and hub assembly have a total oil space.

All oil drain plugs have to be closed before filling with oil.

The whole axle is filled with oil from the differential and carrier assembly, axle housing and hub assembly and together.

The oil level is specified at the respective component (differential and carrier assembly / axle housing and hub assembly).

I = oil filling point

II = oil level inspection point

 = oil level

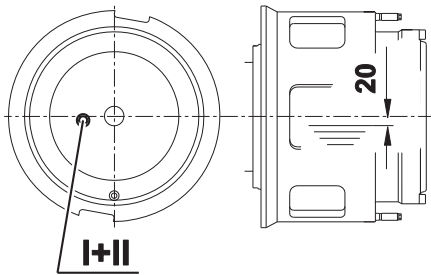

Oil filling and oil level on hub assembly:

1. Clean filling point and oil filling plug.
2. Turn hub assembly into position.
 - The oil drain plug has to be at the bottom.
3. Open the oil filling plug.
4. Fill hub assembly with clean oil until the oil level reaches the filling bore (= inspection bore).
 - Overflow check
 - Oil in accordance with the specified lubricants. [see "Lubricants and lubrication intervals" on page 20](#)
5. After a few minutes, check the oil level again at the filling bores.
 - Keep filling the hub assembly with oil until the oil level remains constant.
6. Clean borehole and oil filling plug.
7. Screw oil filling plug back in.
 - Tightening torque: [see "Tightening torque for screw plugs" on page 49](#)

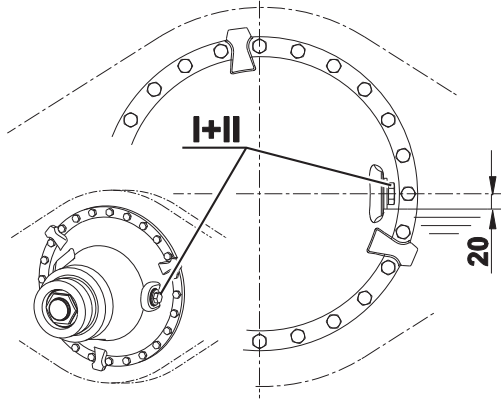

Oil filling and oil level on differential and carrier assembly/axle housing:

1. Clean filling point and oil filling plug.
2. Open oil filling plug.
3. Fill axle and differential and carrier assembly with clean oil until the oil level reaches the filling bore (= inspection bore).
 - Overflow check
 - Oil in accordance with the specified lubricants. See "[Lubricants and lubrication intervals](#)" on page 20.
4. After a few minutes, check the oil level again at the filling bores.
 - Keep filling the axle until the oil level remains constant.
5. Clean borehole and oil filling plug.
6. Screw oil filling plug back in.
 - Tightening torque: see "[Tightening torque for screw plugs](#)" on page 49



Recheck the oil level of the KESSLER product after driving the first time.

9.4 Checking the screwed connections, safeguards, and formation of corrosion

- **Screws at housing connections, steering assembly parts, and brake parts:** If the screws can be retightened, the Loctite connection breaks. Remounting is necessary then! Secure screwed connections and join connections according to specifications, in case of any doubt, please consult KESSLER.
- **Corrosion and cracks** on load-bearing components (e.g. axle spindle) are not permissible for reasons of operational reliability and sealing. Replace any load-bearing components with cracks!
- **Cracks on steering assembly parts** are not permissible for reasons of operational reliability. Replace any steering assembly components with cracks!

9.5 Maintenance intervals

For safety reasons, the vehicle operator has to inspect and service all important screwed connections and safeguards at regular intervals.

Inspection and maintenance-points	Remarks	Maintenance intervals				
		(The value that is reached first is always valid.)				
		after 10 hours of-operation 500 km	after 100 hours of-operation 1000 km	every 500 hours of-operation 5000 km	every 1000 hours of-operation 10000 km	at least 1 x per year
Wheel bearing	Check and readjust		+			+
Wheel nuts	Check and retighten with torque wrench (following a tire change, after about 50 km and about 200 km)	+	+	+		
Nuts / Axle bracket-screws	Inspection and check for firm fit, if necessary retighten	+	+	+		+
Screwed-connections	Check			+		
Gaskets	Check sealing points for leaks	monthly				
Screws / Drive flange	Inspection and check for firm fit, if necessary retighten	+	+	+		+
Parking brake	Check lining thickness and readjust if necessary	+	monthly			
Wet multiple disk brake	Check the lining wear					+

9.6 Checking gaskets

- Check sealing points for leaks. If this is not ensured see Repair instructions.

9.7 Controlling of breather

- Kessler does not stipulate exact intervals for the maintenance of the breather.
- The function of the breather must always be guaranteed.
- The breather must be free of damage, paint and dirt.
- A leaky breather must be replaced.

9.8 Checking of the lining thickness on parking brake

- Lining thickness must be checked with a visual inspection, see ["Supplier documents" on page 51.](#)

9.9 Wheel bearing adjustment

DANGER



When disassembling and mounting wheels on vehicles with clamped rim fixation, damaged parts of the rim may suddenly be ejected explosively due to the tire pressure when loosening the clamped rim fixation.

Serious or fatal injuries of the mechanic

- Release the air in the tire completely before carrying out any work.
- Never stand directly in front of the rim when air is released or while pumping air.

DANGER



Faulty mounting and incorrect securing of the wheel bearing adjustment nut

The wheel along with the complete hub assembly comes off of the axle.

- In any case, tighten and secure the wheel bearing adjustment nut as described!

CAUTION



When loosening the threaded connection, the planetary gear can tip over uncontrolled due to its own weight and fall down.

Danger of being crushed

- Secure the planetary gear against falling with suitable lashing gear during disassembly.

The wheel bearing is checked by retightening the wheel bearing adjustment nut.

- On oil-filled hub assemblies the oil must be drained off.
- On hub assemblies with drum brake the brake drum must be disassembled/mounted if necessary. See supplier's requirements.
- On hub assemblies with planetary gears, the planetary gear and, if necessary, the sun gear are disassembled/mounted.
- On hub assemblies without planetary gears, these steps are omitted. Only the cover is disassembled/mounted.
- The steps loosening / checking / retightening / securing the wheel bearing adjustment nut always remain the same, regardless of the axle type.



Standard execution

Wrench for wheel bearing adjustment nut

Order number: 598938

or



Light way execution

Wrench for wheel bearing adjustment nut

Order number: 598938

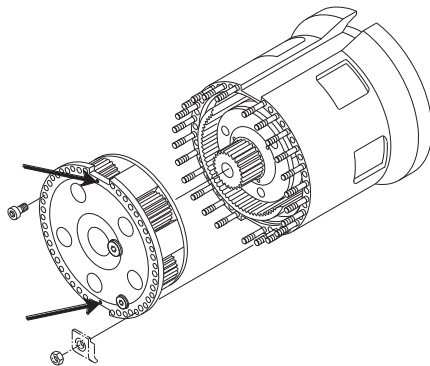

Disassembly of planetary gear:

1. Loosen and remove the screw connection of the planetary gear to the wheel hub.
2. Separate external planetary gear from the wheel hub with the aid of the two forcing threads in the planetary cover / wheel hub.
 - see arrows
3. Remove O-ring from wheel hub.
4. Take out inner planetary stage.

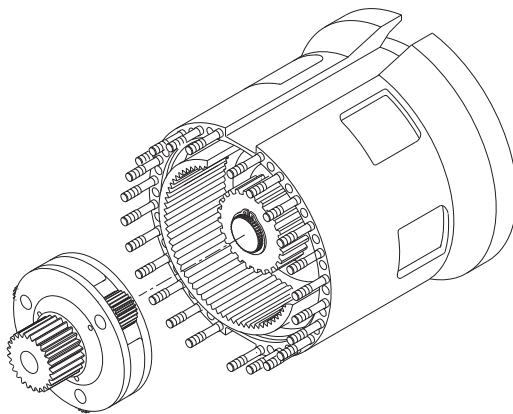

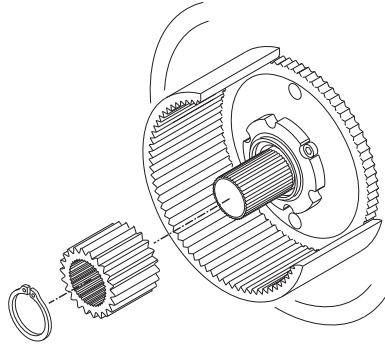
**Disassembly of sun gear:**

5. Remove circlip.
6. Pull sun gear from the universal joint or the axle shaft.

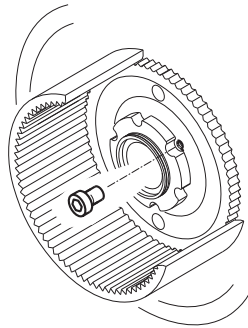
**Loosening the wheel bearing adjustment nut:**

7. Loosen the securing screw of the wheel bearing adjustment nut, clean it and deposit safely.

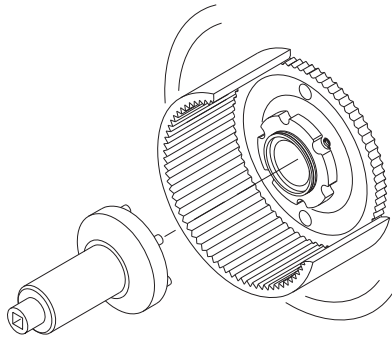
**Checking/Retightening the wheel bearing adjustment nut:**

8. Put the customer service tool on the wheel bearing adjustment nut and tighten to the specified tightening torque.
 - Customer service tool: Wrench for wheel bearing adjustment nut (see above)
 - Tightening torque for used bearings: 750 Nm
 - Rotate the wheel hub several times while tightening.
 - If it is not possible to secure at this position, the wheel bearing adjustment nut needs to be turned forward to the next possible position for securing.

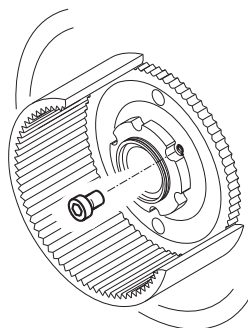
**Securing the wheel bearing adjustment nut:**

9. Secure the wheel bearing adjustment nut with a screw.
 - Hexagon socket screw
 - Screw securing: Loctite 270
 - Tightening torque: 125 Nm

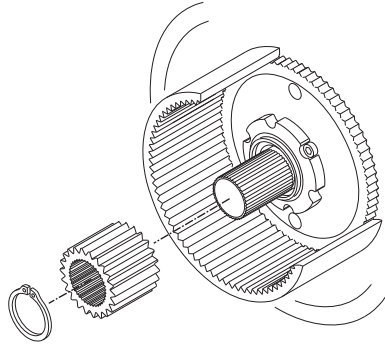
**Assembly of sun gear:**

10. Slide sun gear onto the universal joint or the axle shaft.
 - Bevel of the sun gear is in sliding direction.
11. Mount the circlip.
12. Slide the universal joint or the axle shaft to the inside until circlip contacts the sun gear and the sun gear contacts the thrust ring.
13. Rotate the hub assembly until one of the oil compensating holes of the ring gear carrier is at the bottom position!

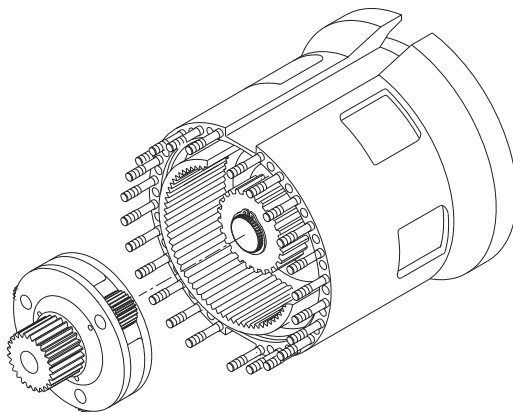
**Assembly of planetary gear:**

14. Slide inner planetary stage into the ring gear and onto the sun gear.
 - **Tip:** Turning the drive flange facilitates the assembly of the planetary stage on the sun gear.

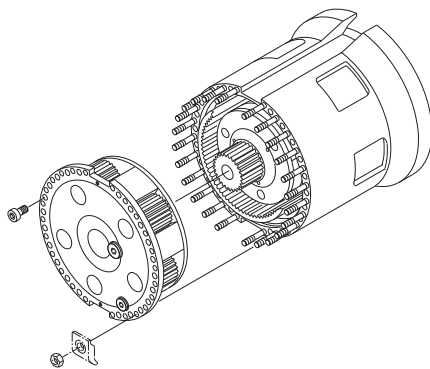

15. Slide external planetary stage into the ring gear and onto the sun gear.
16. Align the boreholes with each other and screw planetary housing to wheel hub with cleaned screws.
 - The oil drain plug has to be at the bottom!
 - Tightening torque: 920 Nm
17. Top up with oil.
 - See ["Oil change" on page 23.](#)

⚠ DANGER



When disassembling and mounting wheels on vehicles with clamped rim fixation, damaged parts of the rim may suddenly be ejected explosively due to the tire pressure when loosening the clamped rim fixation.

Serious or fatal injuries of the mechanic

- Release the air in the tire completely before carrying out any work.
- Never stand directly in front of the rim when air is released or while pumping air.

9.10 Wet multiple disk brake regulations

General:

- Vehicles that are approved for public roads must comply with the ordinances, standards, and regulations of the respective countries. Brake components need to be checked at regular intervals and, if necessary, be repaired or replaced. The regulations of the brake manufacturer must be observed for this.
- Vehicles that are not authorized need to be inspected by an expert in accordance with the respective accident prevention regulations at least once a year.
- If there are indications of thermal overload, consult a brake specialist or the manufacturer.

Replacing the brake lining:

- Worn, burned, or glazed lining disks need to be replaced.
- If this is not observed, the general operating license of the vehicle will be void. Any claims for possible damage will not be acknowledged as well.

Running-in instructions for wet multiple disk brakes:

- When starting up the vehicle, drive carefully to bring the brakes to the operational temperature.
- Drive carefully to get used to the brake effect.

9.11 Lining wear measurement of wet multiple disk brakes

⚠ WARNING



When work is being performed on the brake, its braking effect is disabled.

Rolling away of the vehicle

- Make sure that no machine movements can take place.

⚠ CAUTION



Hot brakes and hot cooling oil

Burns

- The amount of wear rate may be measured only when the vehicle is cold.

Checking the wear rate by comparing the imprinted value (= measurement with new disks) and the value to be measured (= measurement with used brake).

The reference dimension (= measurement with new disks) is imprinted below the wear inspection hole.

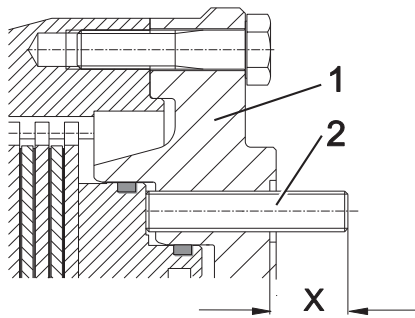

- 1 Brake carrier
- 2 Adjusting screw

1. Disconnect the supply and return lines of the cooling oil from the brake.
2. Drain the oil from the brake. [see "Oil change" on page 23](#)
3. Remove cap nut and lock nut from the adjusting screw (position with the imprinted value).
4. Actuate the brake and screw in the adjusting screw to contact at the piston.
5. Measure dimension X from the adjusting screw end face to the countersink of the brake carrier.
6. Make a note of dimension X.
7. Calculate the difference between the imprinted value with the measured value.
 - If the difference lies within the permissible tolerance, the brake can continue to be used.
 - If the difference is greater than the permissible wear rate, consult KESSLER.
8. After finishing the measurement readjust the given clearance.
 - [see "Readjust the clearance" on page 38](#)
9. Check the cooling oil level in the vehicle.



For Wet multiple disk brake (NLB) 6650, the maximum permissible wear rate is 3.0 mm.

9.12 Readjust the clearance

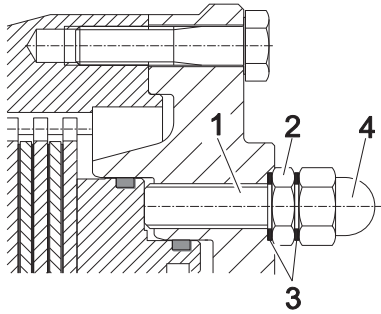

1. With the brake being applied remove cap nuts (4), sealing rings (3), and lock nuts (2).
2. Screw in the adjusting screws (1) all the way at the piston.
3. Turn back the adjusting screws (1) according to the set value of the clearance.
 - Set value of the clearance: see below
4. Add the sealing rings (3) and screw on and tighten the lock nuts (2).
 - Do not turn the adjusting screws (1) when doing so.
5. Add the sealing rings (3) and screw on the cap nuts (4) and tighten loosely.
 - Hold the lock nuts (2) while doing so.



The specified value for the clearance of the wet multiple disk brake 6650 is $4 +0.5/- 0.1$ mm.

10 Ordering spare parts

10.1 Guarantee

KESSLER provides a warranty only for the supplied original spare parts.

Please note that use of spare parts that are not original may negatively modify the specified design characteristics of the axles, gearboxes, drive assemblies, wheel gears, and wheel ends and thus adversely affect the safety.

KESSLER accepts no liability for damage caused by use of non-original spare parts and accessories. Please note that special manufacturing and supply specifications exist for proprietary and third-party parts and that we always offer spare parts according to the latest statutory standards.

10.2 Required specifications for ordering spare parts

The following specifications are needed for ordering KESSLER spare parts:

- Part number (no. of the installation drawing) >>see type plate
- Serial number >>see type plate
- Manufacturer of the vehicle
- Name of the spare part
- Spare part number (drawing or DIN no.)
- Quantity
- Shipping mode

10.3 Type plate

The type plate is usually located near the differential and carrier assembly on the side of the oil filling plug.

The axle serial number is imprinted additionally on the axle housing next to the type plate.

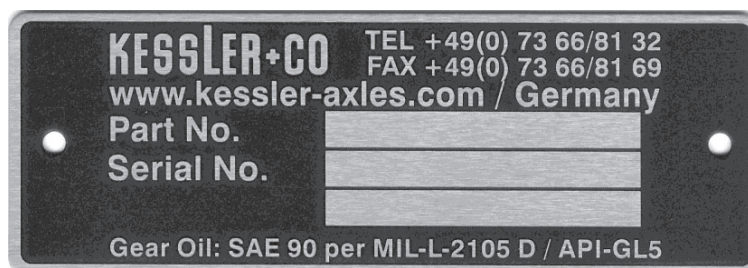

10.4 Necessary consultation with KESSLER

- If there are any questions, please contact KESSLER.
- In the event of major repairs or overhauls, it would be appropriate to send the entire KESSLER product to KESSLER.
- If there are necessary repairs, repair instructions can be requested from KESSLER.

11 Storage

11.1 Standard conservation

Standard conservation of the delivered KESSLER products is sufficient for:

- 18 months - with dry storage in closed rooms
- 12 months - with storage without water ingress
- 3 months - with storage in the open air (breather has to be closed)

11.2 Conditions for storage with standard conservation

Inadmissible and necessary conditions for storage of KESSLER products with standard conservation:

- Open air storage is not permissible in harbor areas (salt water)!
- If the packaging is damaged, renew the packaging!

11.3 Measures for longer storage periods

The following measures are necessary for longer storage periods:

- Oil leaks and water ingress are not permissible; the breather needs to be replaced by a screw plug with sealant.
- Fill units and multiple disk brake with oil.
- Filling volume: 80% of the axle housing volume / hub assembly volume / brake volume / drive assembly volume / gearbox volume.
- Oils to be used:
 - Axle housing / Hub assembly / Drive Assembly / Gearbox: Hypoid gear oil SAE 90 API GL5
 - Multiple disk brake: Shell SPIRAX TXM (Donax TD)

Attention: Do not overfill due to build-up of pressure during temperature fluctuations.

- Apply additional corrosion protection onto uncoated surfaces (for example: rim unit, steering cylinders, brake disks, drive flange, ...).

11.4 Measures before startup after storage

The following measures need to be taken prior to startup of the KESSLER product:

- Remove storage oil and fill KESSLER product with suitable oil to correct oil level.
[Refer to "Oil change" on page 23.](#)
- Check running surfaces of the sealing rings for corrosion. Check sealing points for leaks immediately after startup. If this is not ensured, replace the sealing rings as well.
- Remove corrosion protection completely from uncoated surfaces at startup (e.g. rim unit, steering cylinder, brake disks, drive flanges, ...). Possible surface corrosion on the brake contact surface of the brake disks is a normal und harmless phenomenon. Surface corrosion on the brake disks will be removed automatically by the first brake operations during vehicle commissioning.
- The rim unit needs to be clean and grease-free so that frictional adhesion to the rim is ensured and loosening of rims is avoided.
- Check load-bearing components for corrosion, in particular if stored over several years.

11.5 Responsibility during storage

- The operator has the responsibility for proper storage of KESSLER products and, if applicable, additional necessary corrosion protection measures.

12 Disposal

KESSLER products consist of various materials that can be reused after disposal and must be disposed of separately. The following steps have to be taken.

- Put the vehicle out of operation before starting disassembly.
- Secure the steering assembly parts so that movements are no longer possible.
- Depressurize pressure connections.
- Drain and remove all operating fluids (coolants, lubricants) and dispose of properly.
See "Oil change" on page 23.
- Attach KESSLER product to a suitable hoisting device and disassemble from vehicle.
- Dismantle KESSLER product into individual subassemblies and components.
NOTICE! Dismantling of spring applied subassemblies (e.g. brakes) is not permitted. For this process, the respective safety regulations of the manufacturer must be observed.
- Separate individual parts according to type of material and dispose of according to national and local ordinances as well as valid regulations for the protection of the environment.

13 Important information

13.1 Auxiliary materials: Adhesives, sealing compounds, grease, and assembly pastes



If a screw is used covering with a securing (for example: Precote covering), more Loctite must not apply.

13.1.1 Use of auxiliary materials

Type	Application	Product	Type	Color
Adhesive	Screw securing light	LOCTITE	243	Blue
Adhesive	Screw securing medium	LOCTITE	262	Red
Adhesive	Screw securing very tight	LOCTITE	270	Green
Adhesive	Friction increase in joint faces	LOCTITE	270	Green
Adhesive	Surface sealing	LOCTITE	510	Orange
Adhesive	Special sealing	LOCTITE	572	White
Adhesive	Sealing with wide gap	LOCTITE	638	Light green
Adhesive	Surface sealing	LOCTITE	5926 or 209 125	Blue
Sealing compound	Elastic sealing	Dirko	Grey	Gray
Assembly paste with MoS ₂	Prevents stick-slip	LIQUI MOLY	LM 48	Gray
Multi-purpose grease	Adhesive lubricant	FUCHS	RENOLIT AS	Yellow transparent
Multi-purpose grease lithium soap-based	Bearing lubrication - worked penetration in accordance with NLGI 2	FUCHS	RENOLIT MP150	Yellow transparent
Special grease	Gear-shifting	Klüber	Mircolube GL261	yellow, almost transparent
Assembly-Gel	Elastomer components	Klüber	S06-100	transparent

13.1.2 Handling auxiliary materials

Handling of Loctite 243 / 262 / 270 / 510 / 572 / 638

- The surfaces or screws and threaded boreholes to be cemented need to be free of paint, grease, and oil (washed).
- The Loctite adhesives applied cure under the following conditions:
 - Absence of air
 - Metal contact
 - Warmth
- Only a short time may pass between pre-assembly and controlled tightening (5 - 10 minutes).
- Parts prepared with Loctite intended for cementing can be exposed to air for up to 1 hour.
Exception: Parts made of nonferrous metal may rest for no more than one minute.
- Allow loaded connections to cure for at least 24 hours.

Loctite amount:

For screws: 1 bead

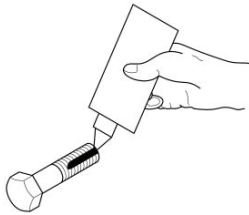

sealing surface: ensure sufficient coating

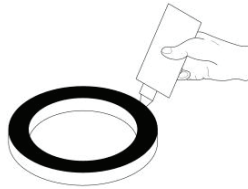

Handling of Loctite 5926

- The surfaces or screws and threaded boreholes to be cemented need to be free of paint, grease, and oil (washed).
- The Loctite adhesives applied cure under the following conditions:
 - moisture curing begins immediately after the product is exposed to the atmosphere
- Parts to be assembled should be mated within a few minutes after the product is dispensed.

Loctite amount:

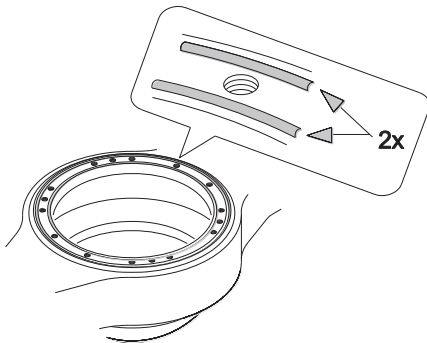

on sealing surface: 2 beads

13.2 Tightening torques

Friction: $\mu = 0.14$

The tolerance of the tightening torques is $\pm 5\%$ (provided that a manual torque wrench is used).

13.2.1 Tightening torque wheel nut

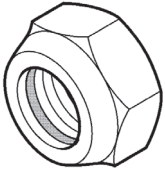
Wheel nut with clamp	Size	Galvanized
	M 18 x 2	350 Nm Tolerance +50 Nm
	M 22 x 1,5	650 Nm

13.2.2 Tightening torques for standard metric threads

Thread size	Screw	Nut	Screw	Nut	Screw	Nut
	8.8	8	10.9	10	12.9	12
M 4	3.0 Nm		4.4 Nm		5.1 Nm	
M 5	5.9 Nm		8.7 Nm		10 Nm	
M 6	10 Nm		15 Nm		18 Nm	
M 8	25 Nm		36 Nm		43 Nm	
M 10	49 Nm		72 Nm		84 Nm	
M 12	85 Nm		125 Nm		145 Nm	
M 14	135 Nm		200 Nm		235 Nm	
M 16	210 Nm		310 Nm		365 Nm	
M 18	300 Nm		430 Nm		500 Nm	
M 20	425 Nm		610 Nm		710 Nm	
M 22	580 Nm		830 Nm		970 Nm	
M 24	730 Nm		1050 Nm		1220 Nm	
M 27	1100 Nm		1550 Nm		1800 Nm	
M 30	1450 Nm		2100 Nm		2450 Nm	

13.2.3 Tightening torques for metric fine threads

Thread size	Screw	Nut	Screw	Nut	Screw	Nut
	8.8	8	10.9	10	12.9	12
M 8 x 1	27 Nm		39 Nm		46 Nm	
M 10 x 1	55 Nm		81 Nm		95 Nm	
M 10 x 1.25	52 Nm		76 Nm		90 Nm	
M 12 x 1.25	93 Nm		135 Nm		160 Nm	
M 12 x 1.5	89 Nm		130 Nm		155 Nm	
M 14 x 1.5	145 Nm		215 Nm		255 Nm	
M 16 x 1.5	225 Nm		330 Nm		390 Nm	
M 18 x 1.5	340 Nm		485 Nm		570 Nm	
M 20 x 1.5	475 Nm		680 Nm		790 Nm	
M 22 x 1.5	650 Nm		920 Nm		1050 Nm	

13.2.4 Tightening torques for galvanized screws and nuts

Observe the reduced tightening torques for galvanized screws and nuts!

13.2.5 Tightening torque for screw plugs

Thread size	Tightening torque (reference values for screws with copper ring)	Tightening torque (sealing plug with O-ring)
M 14 x 1.5	approx. 45 Nm (33 lbf x ft)	45 Nm (33 lbf x ft)
M 16 x 1.5	approx. 60 Nm (44 lbf x ft)	--
M 22 x 1.5	approx. 100 Nm (74 lbf x ft)	100 Nm (74 lbf x ft)
M 24 x 1.5	approx. 120 Nm (89 lbf x ft)	--
M 30 x 1.5	approx. 160 Nm (118 lbf x ft)	--
M 42 x 1.5	approx. 260 Nm (192 lbf x ft)	--
M 45 x 1.5	approx. 280 Nm (207 lbf x ft)	--
9/16-18 UN(F)	--	34 Nm (25 lbf x ft)

13.3 Units

Conversion table

25.40 mm	=	1 in. (inch)
1 mm	=	0.0394 in. (inch)
1 kg (kilogram)	=	2.205 lbs (pounds)
9.81 Nm (1 kpm)	=	7.233 lbf x ft (pound force foot)
1.356 Nm (0.138 kpm)	=	1 lbf x ft (pound force foot)
1 bar (1.02 kp/cm ²)	=	14.5 psi (pound force per square inch lbf/in ²)
0.070 bar (0.071 kp/cm ²)	=	1 psi (lbf/in ²)
1 liter	=	0.264 gallon (imp.)
4.456 liters	=	1 gallon (imp.)
1 liter	=	0.220 gallon (US)
3.785 liters	=	1 gallon (US)
1609.344 m	=	1 mile (land mile)
0°C (Celsius)	=	+32°F (Fahrenheit)
1°C (Celsius)	=	+33,8°F (Fahrenheit)
0°C (Celsius)	=	273.15 Kelvin
1°C (Celsius)	=	274.15 Kelvin

Description of the legal units

Term	Symbol	New	Old	Conversion	Remarks
Moment of torque	T	Nm (Newton meter)	kpm	1 kpm = 9.81 Nm	T (Nm) = F (N) x r (m)
Moment of force	M	Nm (Newton meter)	kpm	1 kpm = 9.81 Nm	M (Nm) = F (N) x r (m)
Pressure	p	bar	atm (gauge)	1.02 atm = 1.02 kp/cm = 1 bar = 750 torr	---

14 Supplier documents

An overview follows with links to data sheets and supplier documentation:

14.1 [Knott - FSG90, FSG110, TM6397](#)

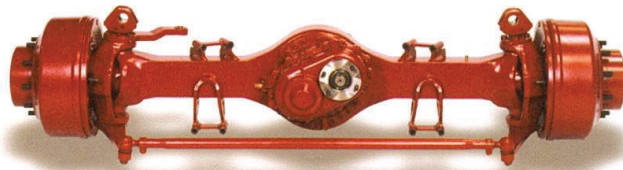
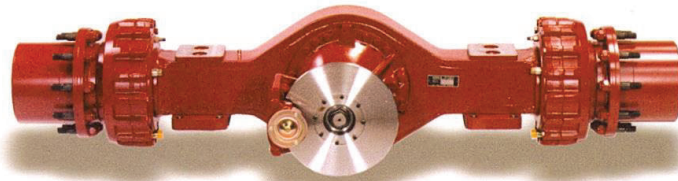
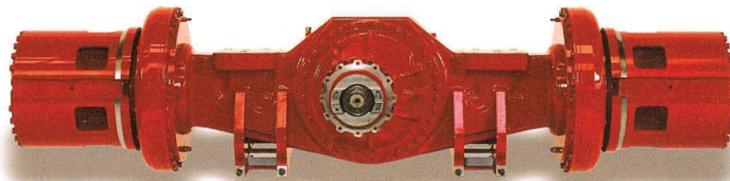
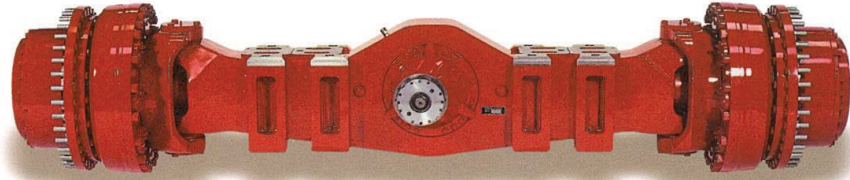

Kessler & Co. GmbH & Co.KG
Huettlinger Straße 18-20
D-73453 Abtsgmuend
Germany

KESSLER+CO

Phone +49 (0) 73 66/81-32
Fax +49 (0) 73 66/81-69
service@kessler-axles.com
www.kessler-axles.de

1. Construction and funktion

Bild 1-1:

Parts of the brake

- 1 housing
- 2 pressure ring
- 3 thrust bolt
- 4 adjusting screw
- 5 bank of cup springs
- 6 piston
- 7 lining pad
- 8 lining pad
- 9 gliding bolt

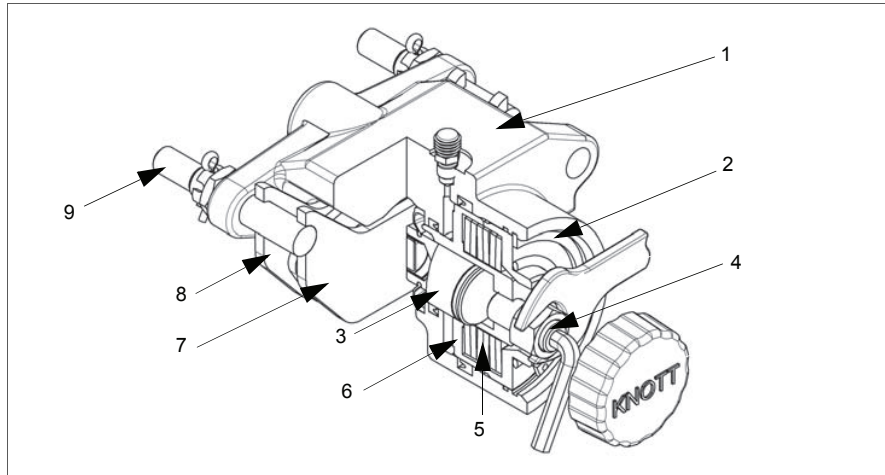

The two identical brake pads and slide freely on the guide bolt, which is fastened in the housing. The guide bolts are guided in an additional brake anchor plate which in turn is screwed onto the vehicle, i.e. its axle.

On actuation, the brake generates a clamping force at the brake lining pads, which cause a tangential force/braking moment to be generated at the brake disk, the extent of which depends on the coefficients of friction generated by the linings.

The clamping force is generated by the bank of cup springs, during which the piston is moved together with the adjusting screw, the thrust bolt and the brake pad towards the brake disk.

When the brake pad comes into contact with the brake disk, the reaction force shifts the housing onto the guide bolts until the brake pad is also pressed against the brake disk.

The brake is released by complete pre-tensioning of the bank of cup springs. During this process, through application of the necessary release pressure after overcoming the cup spring force, the piston must move back until it comes to rest against the pressure ring.

The clamping force diminishes with wear of the brake lining and brake disk. The brake must be adjusted at the latest at the times indicated by the adjusting specification below.

2. Mounting and basic setting regulations

Basic brake setting is required after mounting new brake lining plates or brake disks, as well as during all repair stages and in the event of insufficient braking performance.

Bild 2-1:

Adjusting and assembly possibilities

- 1 thrust bolt
- 2 bank of cup springs
- 3 adjusting screw
- 4 screw cap
- 5 lock nut
- 6 piston
- P even surface
- S socket wrench

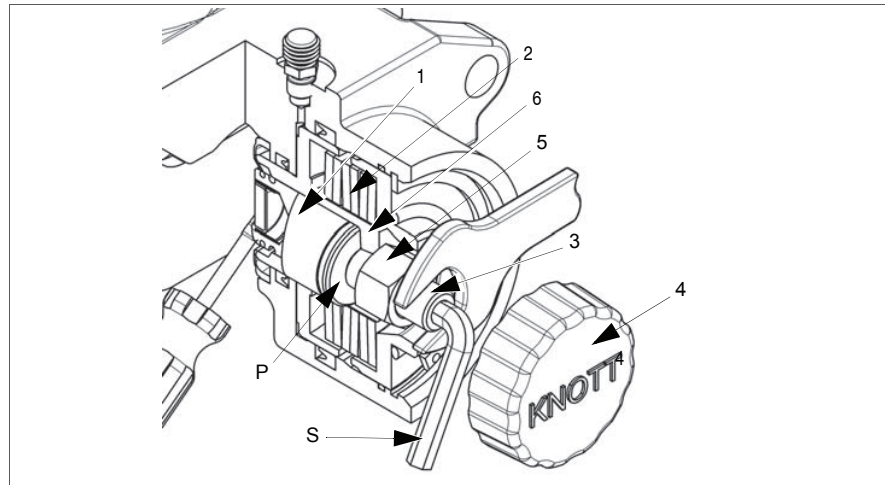

Note:

All mounting and basic setting work must be carried out on the brake when cold.

2.1. Mounting the brake

1. Stand the vehicle on an even surface and secure against rolling away.
2. Release the screw cap.
3. Release the lock nut (size 24 or 30) and turn the adjusting screw anticlockwise using a size 8 or 10 socket wrench until the pressure bolt comes to rest against the even surface of the piston. In this status, the brake can be mounted onto the brake disk and fastened.
4. Mount the pressure connection again.

Apply the necessary release pressure to the brake until the bank of cup springs is completely pre-tensioned

Following carry out the below described basic setting regulation.

2.2. Basic setting regulation

1. Turn the adjusting screw manually clockwise until both brake pads make contact with the brake disk. Then it is not longer possible to turn the adjusting screw without exerting a major amount of force.
2. Turn the adjusting screw anticlockwise in order to set the following rated clearances:

type	adjusting srew	clearance (mm)		turns
FSG90	M16 (SW 8)	min.	0,5	1/4
		clearance	1,0	1/2
		max.	1,5	3/4
FSG110	M20 (SW 10)	min.	1,0	2/5
		clearance	2,0	4/5
		max.	3,0	1 1/5

3. Hold the adjusting screw in position with a hexagonal socket wrench and lock with lock nut.
4. Mount the screw cap and tighten as far as possible manually.
5. Stellen Sie den Druckanschluß gemäß der Vorschrift der Achs- bzw. Getriebehersteller her. Mount the pressure connection in accordance with the instructions of the axle / gear manufacturer.

For bleeding the piston chamber use the socket spanner size 13 for the bleeding valve.

2.3. Adjusting regulations

During this adjusting process, the parking brake must be released, i.e. the bank of cup springs must be completely pre-tensioned.

1. Stand the vehicle on an even surface and secure against rolling away.
2. Release the parking brake by using the required release pressure.
3. Release the screw cap and unscrew.
4. Release the lock nut (size 24 or 30) and turn the adjusting screw with socket wrench size 8 or 10 manually clockwise until the two brake pads make contact with the brake disk.
5. Turn the adjusting screw anti-clockwise and set the clearance specified in the above table.
6. Hold the adjusting screw in position with the hexagonal socket wrench and lock with the lock nut.
7. Mount the screw cap and tighten as far as possible manually.

Actuate the brake valve several times and check the braking efficiency of the parking brake on a slope.

3. Emergency release of the parking brake

After the failure of the pressure release the parking brake by using following manual procedure:

Bild 3-1:

Adjusting and assembly possibilities

- 1 thrust bolt
- 2 bank of cup springs
- 3 adjusting screw
- 4 screw cap
- 5 lock nut
- 6 piston
- P even surface
- S socket wrench

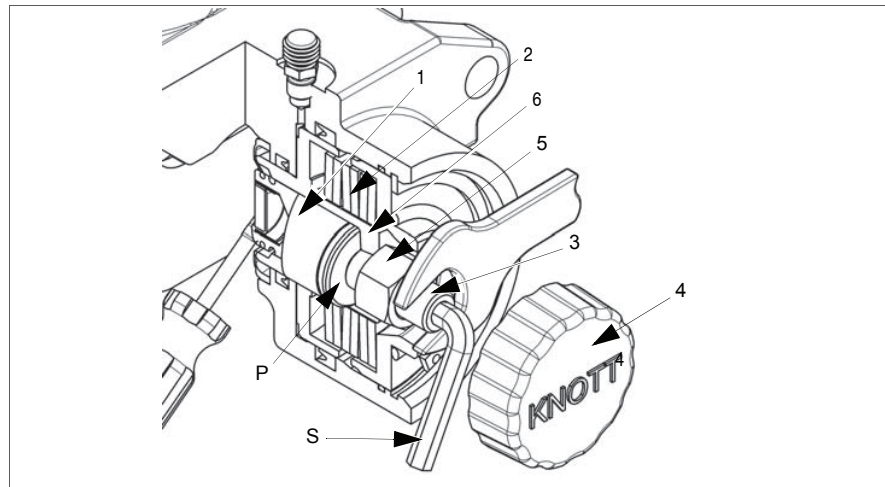

1. The vehicle has to be secured against rolling away.
2. Release the screw cap and unscrew.
3. Release the lock nut (size 24 or 30) and turn the adjusting screw with socket wrench size 8 or 10 manually counter-clockwise until the brake disc is free.



Caution!

For the emergency release is an actuation torque of 40 Nm respectively 70 Nm required .

4. Mount the lock nut and the screw cap and tighten both as far as possible manually. (Protection against dirt



Caution!

Now, the vehicle do not have any brake function. The vehicle must be secured against moving away with proper means. Before putting the vehicle into operation again, the brake has to be adjusted again. Res. „Assembly and basic setting regulations“.

4. Maintenance and repair work

4.1. Maintenance and exchange of brake pads

The brake pads themselves are maintenance free. All that is required here is a check for damaged parts, as well as inspection to ensure that the brake disk remains easy running.

The thickness of the brake lining must be subjected to a visual inspection at regular intervals, which depend on vehicle usage, but every six months at the latest. In the event of a minimal residual lining thickness, these intervals must be reduced accordingly in order to avoid major damage to the brake or disk:

- FSG 90:
min. residual thickness 1,0 mm per lining pad (6 mm carrier plate thickness).
- FSG 100:
min. residual thickness 2.0 mm per lining pad (8 mm carrier plate thickness).

Bild 4-1:
Extending the lining pads

- 1 piston
- 2 adjusting screw
- 3 lock nut
- 4 thrust bolt
- S socket wrench
- S1 screwdriver
- P inside of the piston

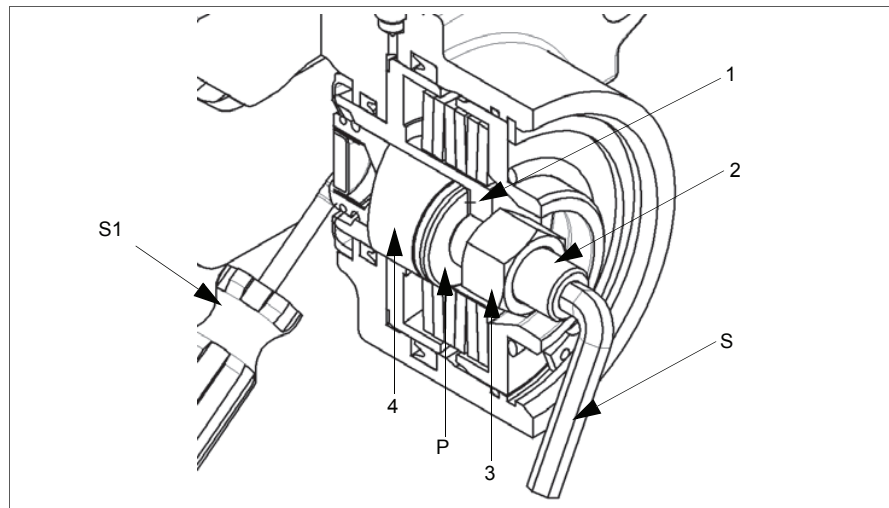

Note:

Only Knott original spare lining plates may be used. If any other spare parts are used, no warranty claims will be accepted either for the brakes or their functional characteristics

1. Stand the vehicle on an even surface and secure against rolling away.
2. Release the parking brake by applying the required release pressure
3. Release the screw cap and unscrew.
4. Release the lock nut (size 24 or 30) and turn the adjusting screw with socket wrench size 8 or 10 manually clockwise until it lies flush with the inside of the piston.
5. Press back the thrust bolt using a suitable screwdriver until it has contact with the piston.

Bild 4-2:
Exchanging the lining pads

- 1 guide bolt
- 2 lining pad
- 3 lining pad
- 4 permanent magnet
- 5 castellated nut
- 6a safety splint
- 6b safety clip

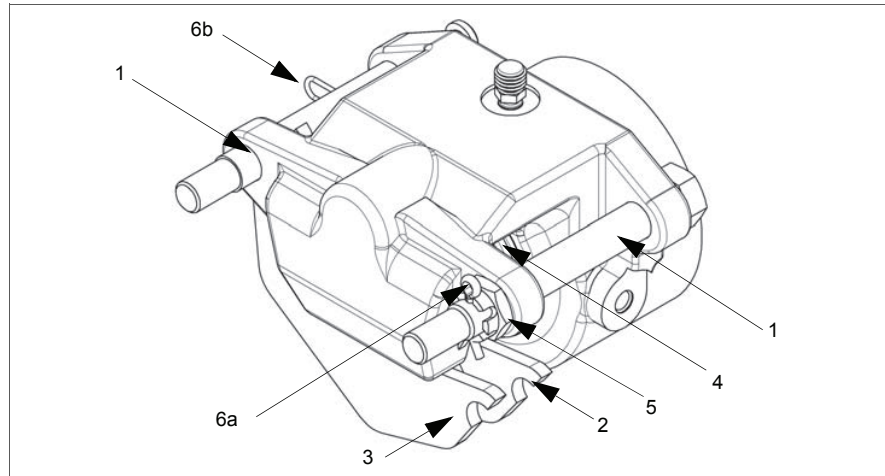

6. Depending on the free space available, release one of the two guide bolts, removing the safety splint, unscrewing the castellated nut and pulling the guide bolt out of the brake anchor plate. Now, the brake lining pads can be removed tangentially to the brake disk.



Note:

In the event of minimal clearance, i.e. it is not possible for space reasons to exchange the brake lining plate in accordance with these instructions, the brake must be removed completely. To do this, pull both guide bolts out of the brake anchor plate.



Caution!

Check the pressure hose. If the pressure hose is too short, it must be unscrewed to remove the brake. Before the pressure hose can be released the brake must be emergency released.

7. Exchange the brake pads and insert the guide bolts into the brake anchor plate. If you have removed the complete brake you have to mount the brake on both guide bolts again, now.
8. Check both permanent magnets if they still have sufficient magnetic force to hold the brake lining plates. Should this not be the case, the permanent magnets must also be changed by using a suitable screw driver.
9. Secure the guide bolt with the castellated nut and the safety splint res. safety clip.



Note:

After mounting new brake lining plates or their repair, the brake must be correctly set in accordance with the instructions „Adjusting regulations“.

4.2. Changing the seal

Bild 4-3:

Change of the seals!

- 1 piston
- 2 adjusting screw
- 3 lock nut
- 4 housing
- 5 circlip
- 6 seal
- 7 guide bolt
- 8 thrust bolt
- 9 bank of cup spring
- A detail of the seal
- B detail of the seal

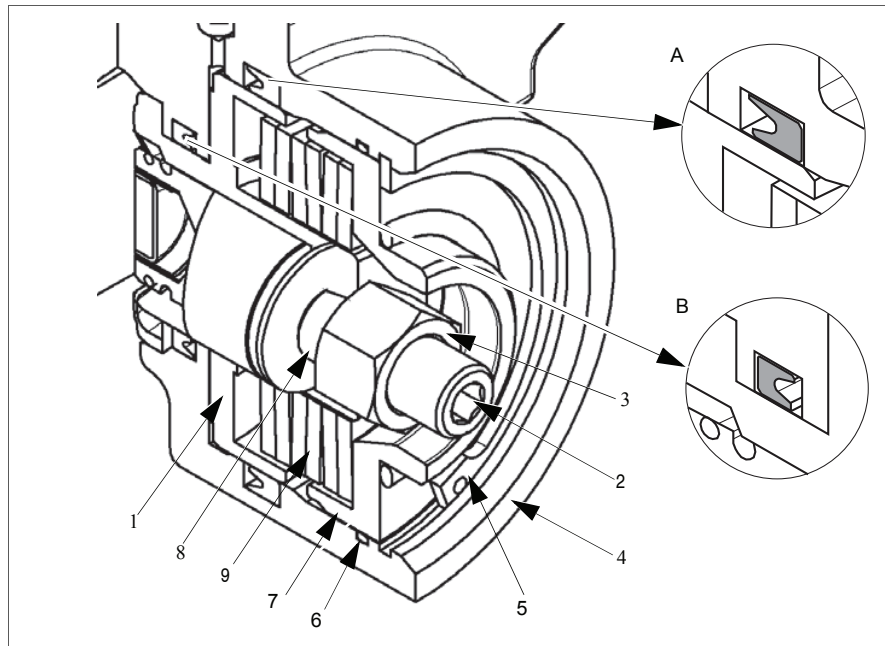

Faulty seals must be exchanged in accordance with the instructions below:

1. Stand the vehicle on an even surface and secure against rolling away.
2. Release the parking brake by applying the necessary release pressure.
3. Release the screw cap and unscrew.
4. Release the lock nut (size 24 or 30) and turn the adjusting screw with socket wrench size 8 or 10 manually counter clockwise until the adjuster screw is flush with the inner side of the piston.
5. Push back the thrust bolt until it has contact with the piston. Following actuate the hand brake valve. (no pressure must be in the piston chamber). The bank of cup springs is now completely depressurized.
6. Unscrew the pressure hose and remove the brake.
7. Release the circlip and remove the pressure ring of the housing.
8. Release the bank of cup springs and the piston.



Caution!

Pay attention to the mounting direction of the seal rings, otherwise leaks can occur.

Use for mounting the new seal rings a suitable mounting needle with rounded edge. Be careful,

9. Change all seals and mount the parts of the brake in other way round order. By mounting the piston, the sliding and sealing surfaces must be greased lightly using lubricating grease to DIN 51825.
The dust protection cap is fitted with a vulcanized-in steel ring which is used to press it through the locating hole. For exchanging, "lever out" the ring using a suitable tool. The new dust protection cap must be pressed in with the aid of a suitable mounting ring and screw clamps or a lever press.

Mount the brake in accordance with the above procedure into the vehicle / at the axle.

4.3. General

Any discovered defects or damage to parts not listed here must naturally be repaired or replaced using original parts.

For any other information not contained in these instructions or for more detailed instructions, please contact the vehicle or brake manufacturer