

## Lubrication L120

Proper and consistent lubrication of articulation points on your Wagner is vital to the longevity of your machine.

An optional automatic lubrication system will lubricate most of the points on your Wagner, but inspection of these points is still necessary to ensure the automatic system is working properly.

**Note:** Manual lubrication is always required for the drivelines, and the steering column.

**Note:** The drivelines require a different grease than the rest of the machine. See Fluids chart in Section 5-2, or the tables on page 5-3-2 for details.

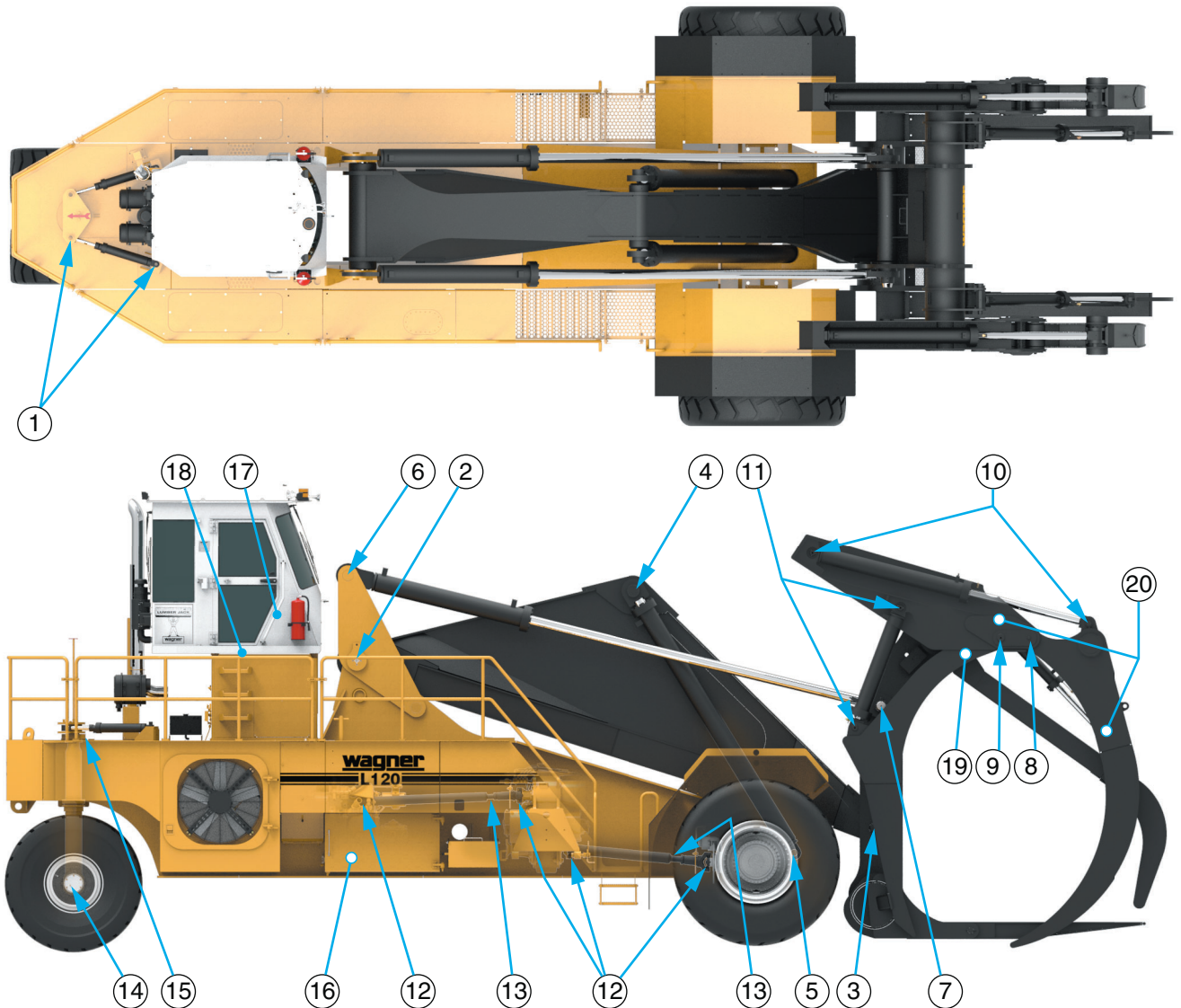

Figure 1 Lubrication Points

# Lubrication Schedule

Refer to: Figure 1

## 10 Hours

Before engine startup, check the following:

①	Steering Cylinder Pins	Mobilgrease Special No. 2
②	Boom To Chassis Pins	
③	Boom To Carriage Pins *a	
④ & ⑤	Hoist Cylinder Pins *a	
⑥ & ⑦	Tilt Cylinder Pins	
⑧	Holddown Arm Pins	
⑨	Kickoff Arm Pins	
⑩	Holddown Cylinder Pins	
⑪	Kickoff Cylinder Pins	
⑲	Aux Holddown Arm Pins	
⑳	Aux Holddown Cylinder Pins	

## 50 Hours

⑫	Driveline Cross Assemblies *b*c (refer to service form 80-627)	Mobilith SHC 220 Grease
⑯	Optional Automatic Grease System. Check grease level. See 80-1052 for service and maintenance information.	Mobilgrease Special No. 2

## 250 Hours

⑱	Seat Platform Swivel Bearing *c (grease fitting located under cab)	Mobilith SHC 220 Grease
---	---	-------------------------

## 500 Hours

⑭	Tailwheel Bearing	Mobilgrease Special No. 2
⑮	Tailpost	
⑯	Optional Automatic Grease System. Clean or replace grease filter. See 80-1052 for service and maintenance	

## 1000 Hours

⑬	Driveline Slip Yokes *b*c (refer to service form 80-627)	Mobilith SHC 220 Grease
---	--	-------------------------

## 2000 Hours

⑰	Steering Column U-Joints *c	Mobilgrease Special No. 2
---	-----------------------------	---------------------------

\*a When operating in water, lubricate submerged points more frequently.

\*b Use handgun or lower pressure adaptor; lubricate sparingly.

\*c Not lubricated by optional automatic grease system.