

Daily/Shift Maintenance

Note general vehicle condition. Clear away all collected debris - steam clean if necessary. Check for mechanical damage and loose or leaking components. Report all faults to maintenance department.

Always refer to manufacture's (e.g. engine, transmission, axle) maintenance manual before performing any maintenance.

Before Starting Engine, Check the Following:				
Ref	Component	OK	NO	ADD
1	ENGINE (Check oil level - check for leaks)			
2	ENGINE BELTS & DRIVEN EQUIPMENT (Check for loose belts, fasteners, etc)			
3	COOLERS & FANS (Check for damage - clear debris buildup)			
4	HYDRAULIC TANK (Check oil level - check for leaks)			
5	COOLANT LEVEL CHECK (Check coolant level - check for leaks)			
6	AIR CLEANER/INTAKE SYSTEM (Check indicator - clean / change element if indicator shows red, check for leaks / damage)			
7	FUEL/WATER SEPARATOR (Drain)			
8	WHEELS & TIRES (Check condition and pressure)			
9	TORQUE WHEEL NUTS (Daily for first 50 hours, every 100 hours thereafter)			
10	LUBRICATE CHASSIS (Refer to lube chart)			
11	WALK AROUND INSPECTION OF STRUCTURE (Check welds, leaks, damaged components, etc...)			
12	FIRE SAFETY CHECK (Check for accumulated debris in engine compartment, etc)			
13	FIRE SUPPRESSION SYSTEM (Verify certifications are current)			
14	TRANSMISSION (Check oil level)			
15	DEF Tank (Check level. Fill as necessary.)			

After Starting Engine, Check the Following:				
Ref	Component	OK	NO	ADD
16	ENGINE (Does it sound normal?)			
17	INSTRUMENTS AND CONTROLS (Check for normal readings and functioning)			
18	AIR INTAKE SYSTEM (Inspect all connections)			
19	EXHAUST SYSTEM (Check for leaks and excessive smoke)			
20	CHARGE AIR PIPING (Check for leaks and inspect all connections)			
21	AFTERTREATMENT EXHAUST PIPING (Check for leaks and inspect all connections)			
22	TRANSMISSION (After warming to operation temp, check oil level - check for leaks)			
23	HYDRAULIC FILTERS (Check indicator - change element as required)			

Note Anything Abnormal or in Need of Repair:	
Component	Comments
LIGHTS	
DEFROSTER	
REVERSE WARNING HORN	
HORN	
WINDSHIELD WIPERS	
HEATER / AIR CONDITIONER	

OPERATOR _____

SUPERVISOR _____

DATE _____

MODEL _____

SERIAL No _____

HOUR METER _____

Daily Maintenance Procedures

General

The following maintenance procedures should be performed at the beginning of each work shift. The numbers before each maintenance procedure correspond to the numbers on the charts on the previous page.

Before Starting Engine

1. Engine

The oil level should be checked prior to starting the engine. The dipstick, sight gauge, and fill port are located on the right side of the machine, just in front of the cooling fan (See Figure 1). Make sure that the area around the dipstick is clean and the machine is sitting on level ground.

NOTE: A 15 minute drain-back time is recommended if the engine has been running.

The oil level must be maintained between the “L” (low) mark and the “H” (high) mark, but as close to the “H” mark as possible.



CAUTION

Never operate the engine with the oil level below the “L” mark or above the “H” mark. Refer to the engine’s Operation and Maintenance manual for detailed engine service information. Use only approved engine oil (see Lubricant Specifications Chart). Do not overfill. Check engine for leaks.

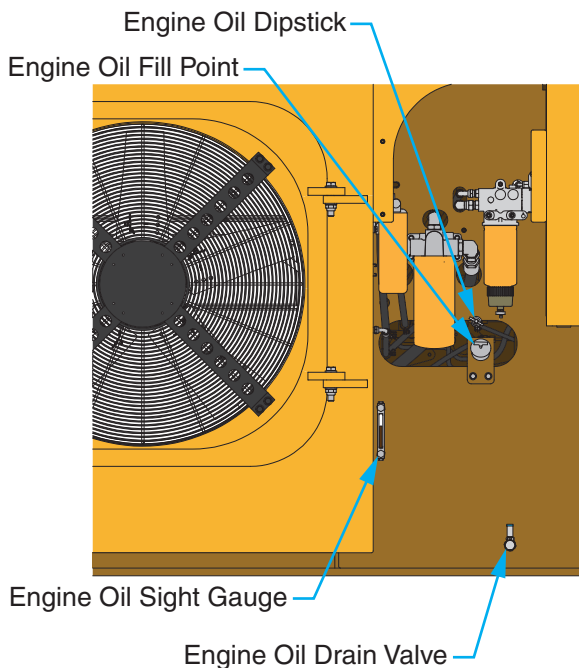

Figure 1 Engine Oil Dipstick & Fill Tube

2. Engine Belts and Driven Equipment

If any belt is loose or worn, report to maintenance for corrective action. Check the connection between the engine and torque converter. Consult the manual supplied with your engine for inspection procedures.

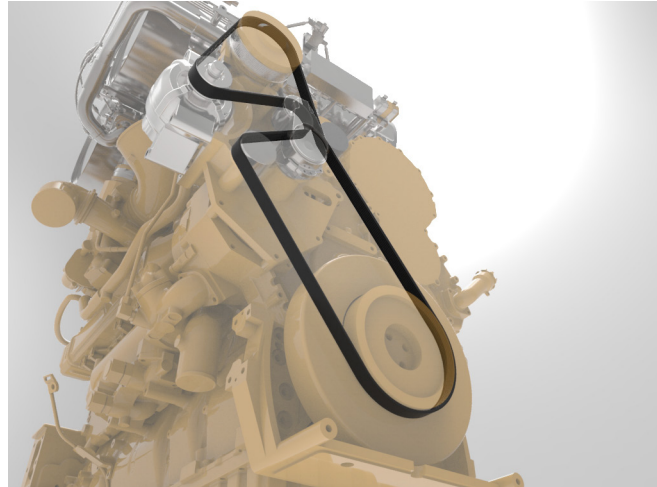

Figure 2 Engine Belt Deflection

3. Coolers and Fans

A visual inspection of the coolers and fans is required daily. Check coolers on both sides of the chassis. Inspect for any damaged or bent components or leaking connections. Clean any debris buildup in the cooling bays. Ensure that the fan blades are not damaged and are free to rotate.

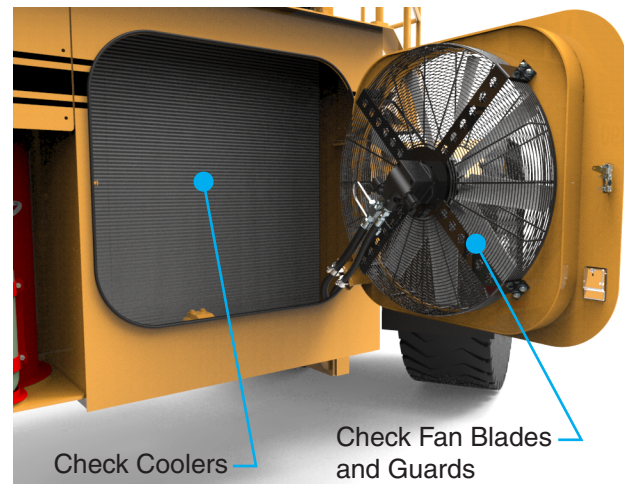

Figure 3 Radiator/Fan Inspection

4. Hydraulic Tank

CAUTION

Always open the tank breather petcock (located on the breather pipe) before adding oil at the fill port. Failure to vent tank can result in injury or a substantial oil spill. Be sure to close the petcock before operating the machine.

Always check the hydraulic oil level prior to operation. The sight gauge is located on the right side of the chassis (See Figure 4). Oil added at the pressure fill port is directed through the return filters before entering the tank to keep your oil as clean as possible.

The oil level should be checked with the carriage in the normal park position (see Section 4-2). The oil level should be at or near the “H” (high) mark on the sight glass. Fill with approved hydraulic fluid as required. Do not overfill.

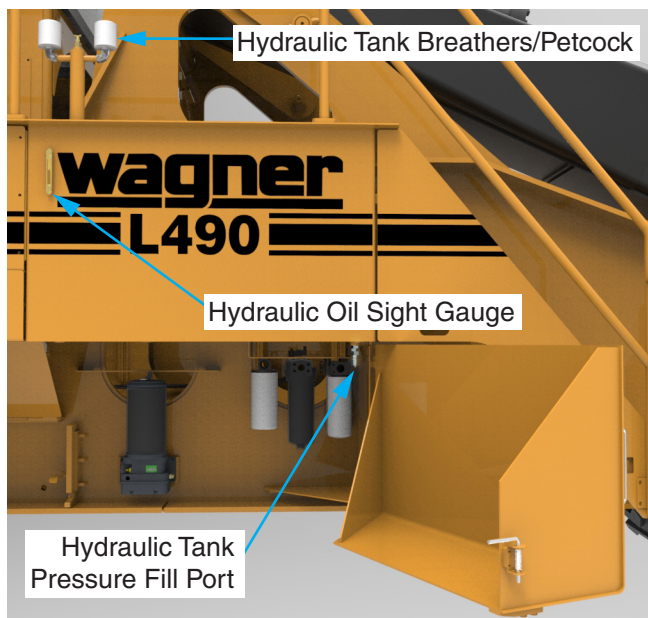

Figure 4 Hydraulic Oil Dipstick and Fill

5. Coolant Level Check

Inspect the coolant level daily. The coolant reservoir sight gauge and fill cap are located on the left side of the chassis, under the cab (See Figure 5). Cooling systems using anti-aeration baffles restrict visual observation of the true coolant level. Although the coolant can be seen, the system may not be full. To gain a true fill, add water slowly up to the bottom of the fill neck and allow a 30 second settling period. Remember to compensate for the loss of antifreeze when adding water.

WARNING

Never remove the radiator cap if the engine is hot. The coolant will be under pressure and could flash to steam with explosive force, causing severe burns. Remove the radiator cap only when the engine is cool.

NOTE: If the engine is hot, the coolant will be higher than when it is cold. Inspect the radiator daily for restriction caused by leaves, paper or bent fins. Inspect the radiator cap, hoses and connectors for any signs of leakage or damage.

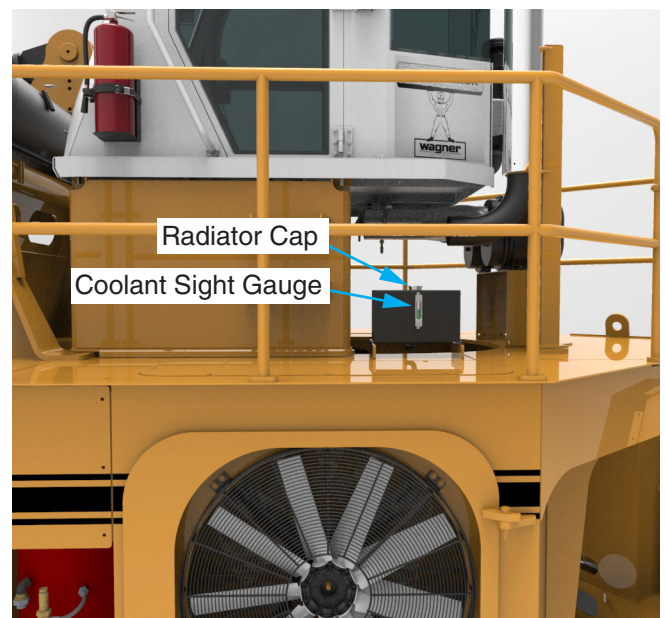

Figure 5 Coolant Fill and Sight Gauge

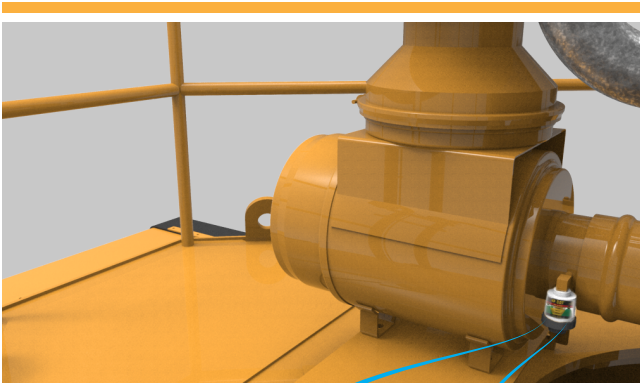

Figure 6 Air Filter Service Indicator

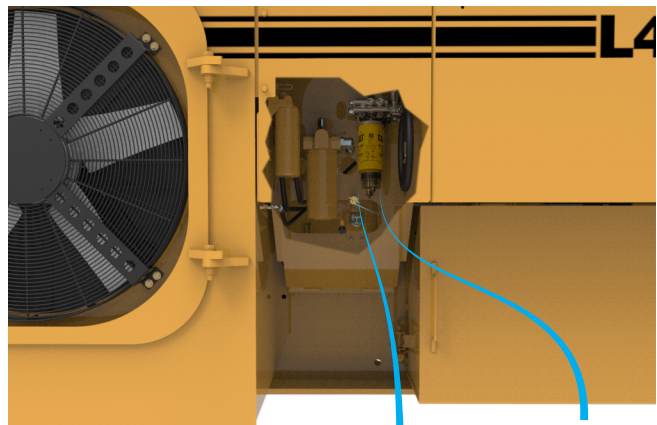

Figure 7 Fuel Water Separator

6. Air Cleaner/Intake System

The air cleaner is a two stage dry air filter, mounted behind the cab.

A service indicator (See Figure 6) shows the condition of the filter. Check the indicator daily, and clean or replace the air cleaner elements as necessary. Consult the Operation and Maintenance manual for your engine for details.

7. Fuel/Water Separator

The fuel/water separator is mounted on the chassis, right side (See Figure 7). Drain the fuel/water separator into a container and dispose of in accordance with local environmental regulations. Consult the Operation and Maintenance Manual for your engine for details.

8. Wheels & Tires

Visually inspect the tires for low air pressure and damage. Also check the wheel assemblies for cracks, loose or missing lug nut, broken studs, etc. Report any problems to maintenance.

9. Torque Wheel Nuts

Torque the wheel nuts daily for the first 50 hours, and every 100 hours thereafter. To eliminate over-torque, always use a torque wrench and torque to:

Front Axle: 450-500 ft-lbs.

See form 80-891 for details.

10. Lubricate Chassis

Refer to Section 10-1.

11. Walk Around Inspection Of Structure

Walk around the machine and inspect for structural cracks. If cracks are present, repair before resuming operation. Refer to Allied Service Form 80-850 for information on how to properly weld structural cracks.

12. Fire Safety Check

Inspect for and remove all combustible materials from engine area. These materials build up in tight corners and are highly combustible.

Inspect the driveshaft and brakes for debris and remove as necessary.

13. Fire Suppression System

Your Fire Suppression System should be activated and certified upon machine delivery, and periodically maintained by a qualified ANSUL representative. Check that the system's certifications are current before operating the machine. Contact your local ANSUL representative for details.

14. Transmission Oil Level

The transmission oil sight gauge and fill port are accessible from the right side stairwell (see Figure 8).

Always check the transmission oil level prior to starting the engine to be sure there is oil in the sump. The cold oil level must be above the "L" (low) mark on the dipstick.

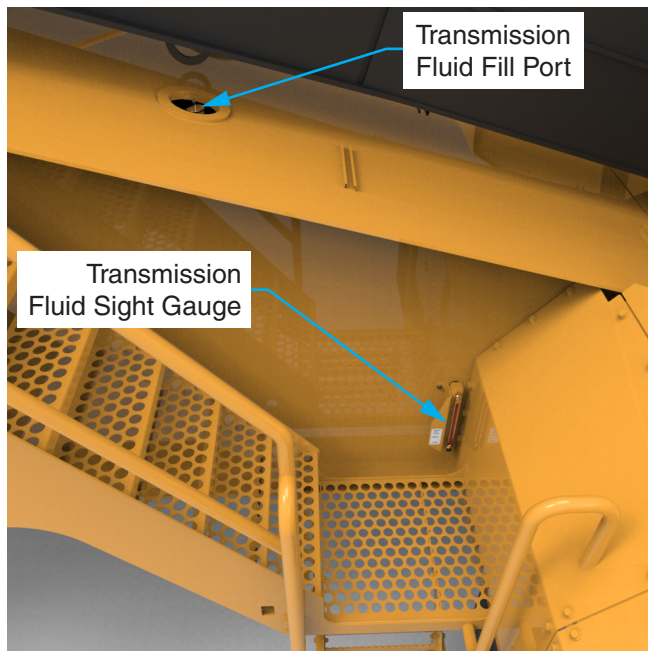

Figure 8 Transmission Oil Dipstick and Fill



Figure 9 DEF Tank

15. DEF Tank

The DEF tank must not be allowed to run dry. It MUST be checked daily. Refill as necessary. Do not overfill. The DEF tank is located on the left side of the chassis, just in front of the diesel tank. See Figure 9.

After Starting Engine

16. Engine

After starting, check that the engine runs and sounds normal. It should come up to operating temperature and pressure within a few minutes after starting. Refer to the operation and maintenance manual for your engine for details. If you notice unusual noises or excessive smoke, have maintenance check it out.

17. Instruments and Controls

Check all instruments for normal readings immediately after starting engine. Make sure that pressures and temperatures are within acceptable limits. Also, check that all controls function properly. They should be smooth and responsive. See Section 2 in your operator's manual for details.

18. Air Intake System

Inspect all connections for damage, loose clamps, and air leaks. Look for damaged fittings and loose connections. Do not operate the machine if leaks are present. Dirt could enter the engine intake and cause severe damage.

19. Exhaust System

Check for leaks. Make sure that exhaust gases are not entering the operator's cab. Mounting brackets must be in place and all connections tight. Check for excessive smoke.

20. Charge Air Piping

Inspect all connections for damage, loose clamps, and air leaks. Look for damaged fittings and loose connections. Mounting brackets must be in place and all connections tight.

21. Aftertreatment Exhaust Piping

Inspect all connections for damage, loose clamps, and air leaks. Look for damaged fittings and loose connections. Mounting brackets must be in place and all connections tight.

22. Transmission Oil Level

The transmission oil sight gauge and fill port are accessible from the right side stairwell (See Figure 8). The level should be checked again after the engine warms up, with 180 to 200 showing on the transmission temperature gauge.

Check oil level with engine running at idle, at operating temperature, and with the transmission in neutral. The level should be between the "H" (high) and "L" (low) marks. Fill with approved fluid only (see Section 10-1). Do not overfill. Inspect for leaks.