

## PARTS BULLETIN

DATE: August 13, 2021

BULLETIN NO. \_\_\_\_\_ PMB1307

PAGE: 1 of 1

MODEL(S): \_\_\_\_\_ Bull Gear Balers

ATTENTION: FREEMAN DEALERS, PARTS, AND SERVICE MANAGERS

SUBJECT: Improved design of the pinion bearings on the Freeman Bull Gear balers.

### BACKGROUND:

Allied Systems has updated the design of the pinion bearings with a new pinion bearing kit which includes all necessary parts for replacement as well as instructions to do so. The old style pinion bearing was made of cast, causing it to be more prone to damage and failure. The new style of pinion bearing is made of steel and is more resistant to damage and failure.

If your customers' baler have the old style pinion bearing (P/N: 906113) currently installed, recommend that they order the updated replacement kit (P/N: 908346).

### CORRECTIVE ACTION:

Allied Systems recommends replacing the older style pinion bearing with the new pinion bearing kit (P/N: 908346).

OLD STYLE PINION BEARING  
P/N: 906113

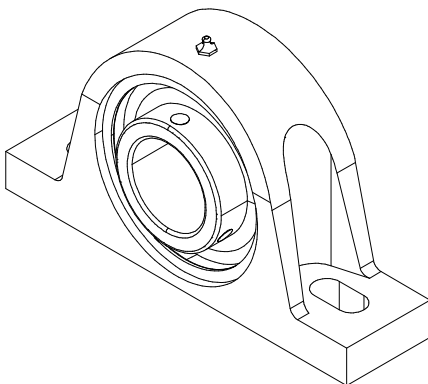

NEW STYLE PINION BEARING  
ORDER KIT P/N: 908346

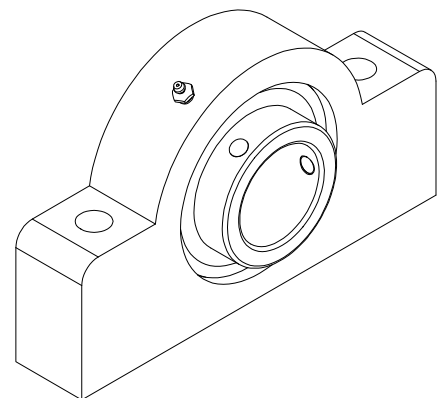

WARRANTY STATUS: NONE

For questions or concerns, please contact your local dealer or Allied Systems Company Service Department at (503) 625-2560.