

Long Reach Multi-Pallet Handlers

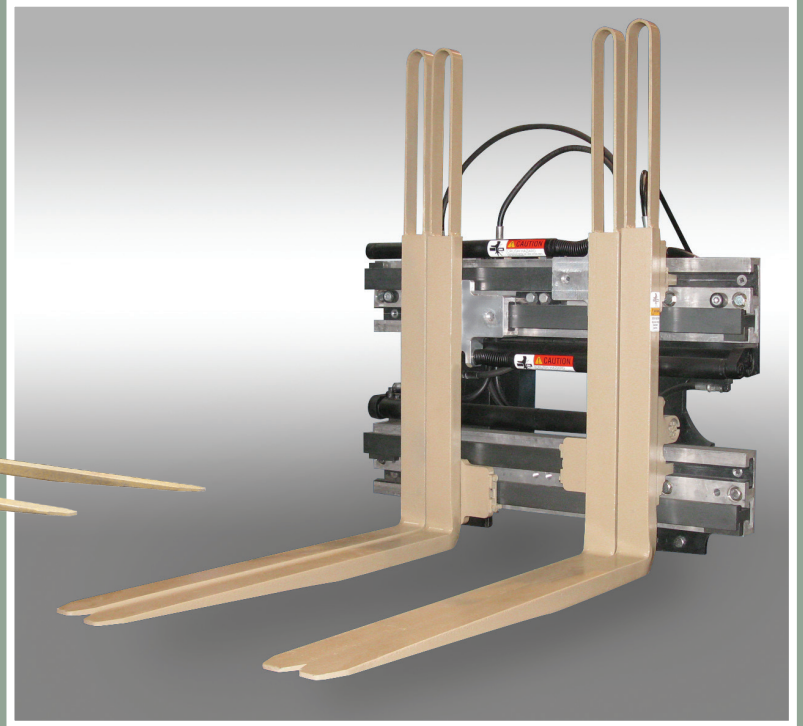
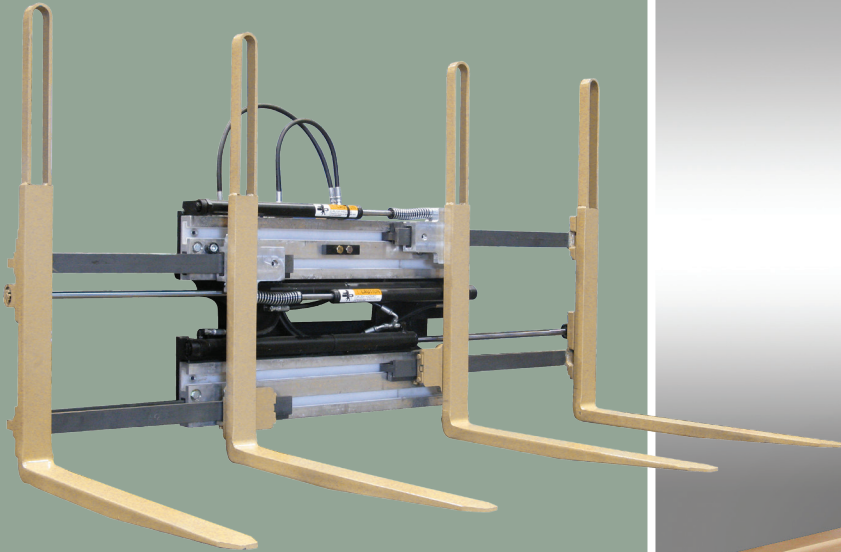

Versatile Design

- Increase productivity and reduce cost with a Long Reach multi-pallet handler. This model efficiently handles either one or two pallets.
- Flow divider for equal arm movement.
- Easy installation with bolt-on or quick mounting hooks—no welding required.
- Unobstructed view of floor level and second tier stacking heights.
- Handles CHEP® and GMA pallets.
- Other models designed specifically for the beverage industry.

Durability

- Heavy duty bronze sideshift hooks ensure long service life.
- High capacity wear strips keep arms rigid.

No-fuss Maintenance

- Service cylinders from the front.
- Interchangeable outer and inner forks.
- “Repair-N-Place” no-lube polymer wear strips can be replaced in just minutes—your load stays grease-free.

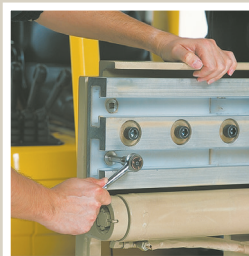

Long Reach Multi-Pallet Handlers

Sideshifting Single/Dual Pallet Handler, 2 Functions

Model Number	Capacity lb @ 24"	Fork Size W x L (in)	Inner Fork Range ITI	Outer Fork Range OTO	Fork Set Spacing OTO	Body Width (in)	Mounting Class	Lost Load AET (in)	HCG (in)	VCG (in)	Weight (lb)
LFDA55SFC336-5A	5,500	3 x 36	13.5-26	26-80	27	41	II or III	8.5	7.6	11.3	1,070
LFDA55SFC342-5A	5,500	3 x 42							8.2	10.9	1,090
LFDA55SFC332-5B	5,500	3 x 32	11-27	24-75	24	41	II or III	8.5	6.3	11.8	1,005
LFDA55SFC336-5B	5,500	3 x 36							6.9	11.5	1,030
LFDA50SFC342-55	5,000	3 x 42	16-30	28.8-87.3	28.5	43	II or III	8.5	8.1	11.0	1,115
LFDA50SFC348-55	5,000	3 x 48							8.5	10.8	1,125
LFDA55SFC342-55	5,500	3 x 42	16-30	28.3-87.3	28.5	43	II or III	8.5	8.1	11.0	1,115
LFDA55SFC348-55	5,500	3 x 48							8.5	10.8	1,125
LFDA70SFC442-70*	7,000	4 x 42	20-29	33-87	29	48	III	8.6	8.0	11.2	1,315
LFDA70SFC448-70*	7,000	4 x 48							8.9	10.9	1,345

Single/Double/Triple Pallet Handler

LFT-55NS-FM332	5,500	3 x 32	Consult Factory			48	II or III	Consult Factory for Specifications			
----------------	-------	--------	-----------------	--	--	----	-----------	------------------------------------	--	--	--

Capacities to 9,000 lb available; consult factory.

Specifications are with standard loop-type 48" high load backrest. Other load backrest options available, including tubular and interlocking.

*Outer fork widths on LFD-70 models are 4.0"; inner forks are 3.0" wide.

Some model KOOI REACHFORKS® can be incorporated into the design of LFD models. Consult factory for more information.

Put productivity up front with pallet handling flexibility from Long Reach.

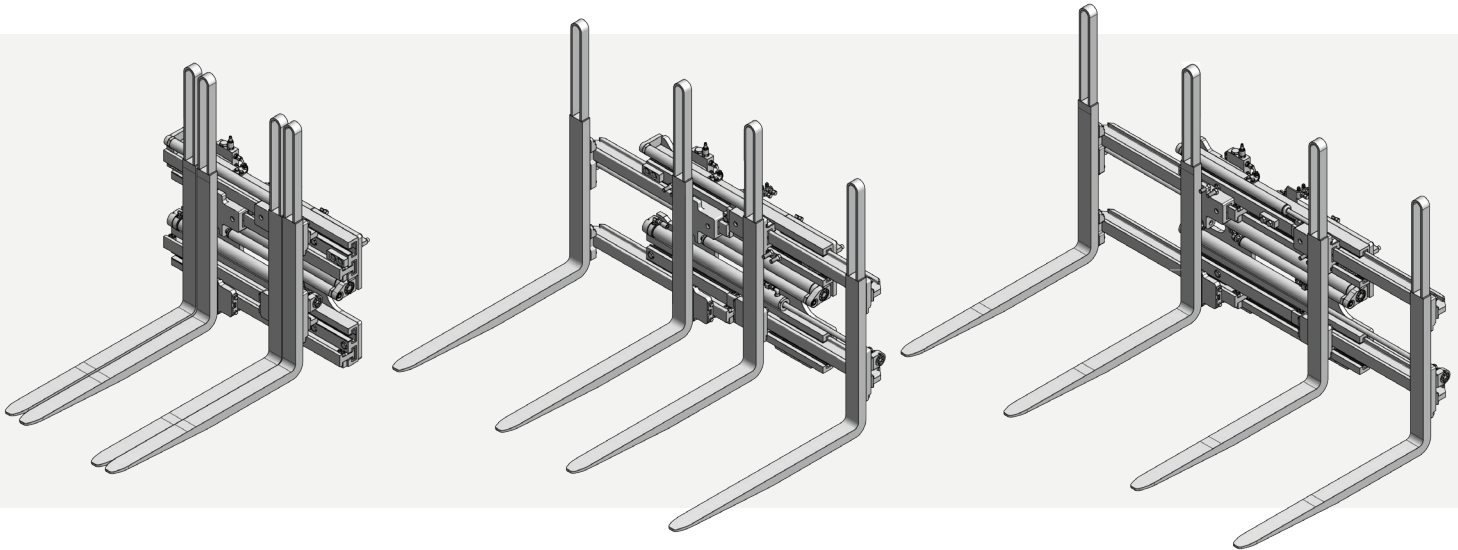

Choose Long Reach for serviceability, value, and custom design

Multi-Pallet Handlers
Fork Positioners
Integral Carriages
Paper Roll Clamps
Lateral Clamps

Carton Clamps
Push-Pulls
Rotators
Custom Design

21433 SW Oregon Street
Sherwood, Oregon 97140-9799 USA
Toll free: (800) 285-7000
Phone: (503) 625-2560
Fax: (503) 625-7269
Email: marketing@alliedsystems.com
www.alliedsystems.com/Longreach

LONG REACH®
A Division of Allied Systems Company