

Long Reach Rotating Pallet Fork Clamp

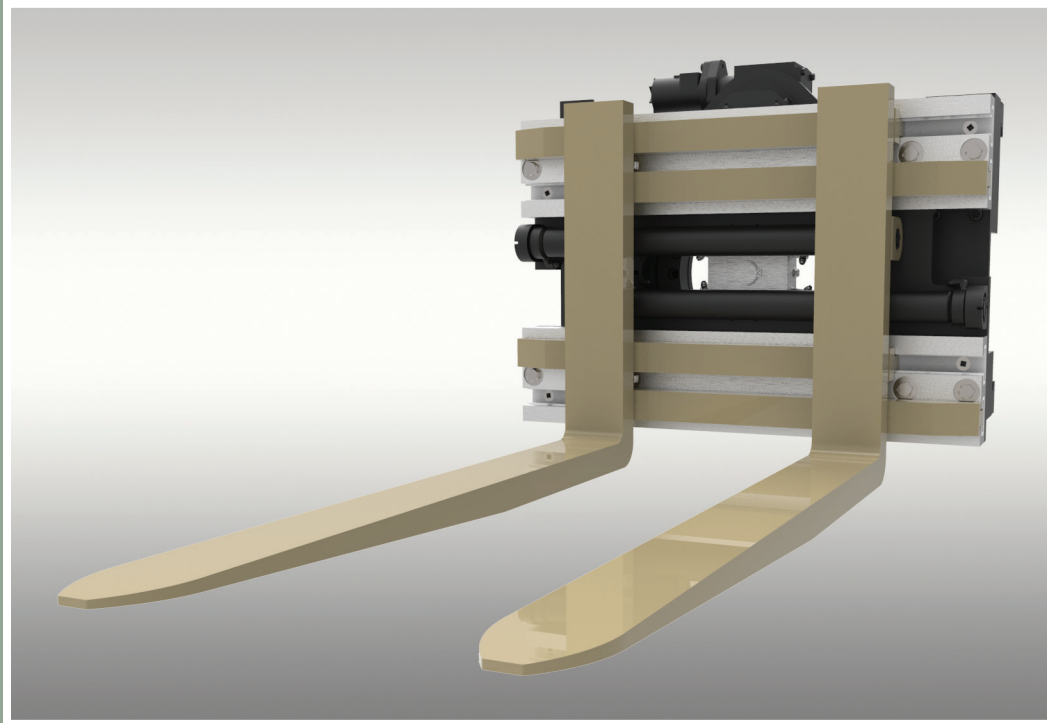

Efficient Clamping, Rotating and Fork Positioning in One Attachment

Perfect for any application requiring strength, durability and versatility, this Long Reach attachment allows forks to be spread to handle wide loads without increasing carriage width. Functions as a clamp, fork positioner and rotator with capacities from 2,500 lbs to 14,000 lbs and opening ranges from 14 inches to 88 inches.

Applications

- Recycling operations
- Food processing
- Manufacturing

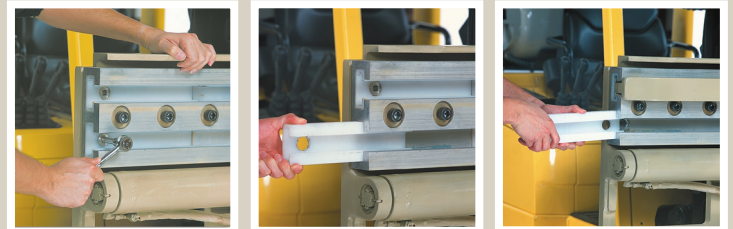

Repair-N-Place serviceability means no-lube polymer wear strips can be replaced in just minutes.

Features

- Precise fork positioning enhances overall handling efficiency
- All hoses, valves and fittings can be serviced from the front of the truck on most models
- Weld-on forks for maximum strength
- Clean, grease-free handling — no lubrication required
- High net truck capacity
- Four degree (4°) mounting available

LCS/NSQ 360° Rotating Pallet Fork Clamps

Weld-on forks for maximum strength
 Clean, grease-free handling — no lubrication required
 High net truck capacity
 Four degree (4°) mounting available

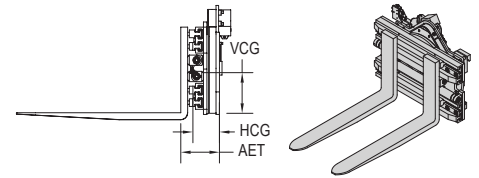

360° Rotating Pallet Fork Clamps, 2 Functions

Model Number	Capacity lb @ 24 ¹	Opening Range (in) ¹	Fork Size T x W x L (in)	Mounting Class	Angle (°)	Lost Load AET (in)	HCG (in)	VCG (in)	Weight (lb)	
LCS-25RN-FD536	2,500	14.0–60.8	2 x 5 x 36	II	0	12.8	9.7	8.8	1,210	
LCS-25RN-FD542			2 x 5 x 42				10.5	8.8	1,240	
LCS-25RN-FD548			2 x 5 x 48				11.3	8.8	1,265	
LCS-35RN-FD536	3,500	14.0–65.8	2 x 5 x 36	II	0	12.8	9.7	8.9	1,250	
LCS-35RN-FD542			2 x 5 x 42				10.4	8.8	1,280	
LCS-35RN-FD548			2 x 5 x 48				11.2	8.7	1,310	
LCS-50RN-FD636	5,000	15.0–69.4	2 x 6 x 36	II or III	0	12.8/13.1	10.2/10.0	9.6	1,650	
LCS-50RN-FD642			2 x 6 x 42				11.0/10.1	9.5	1,690	
LCS-50RN-FD648			2 x 6 x 48				11.9/11.7	9.3	1,730	
LCS-50RN-FD654			2 x 6 x 54				12.8/12.6	9.0	1,770	
LCS-70RN-FF642	7,000	22.0–86	2.5 x 6 x 42	III	0	16.5	11.6	15.5	2,403	
			IV	17.4			11.6	15.5	2,428	
LCS-70RN-FF648			2.5 x 6 x 48	III			16.5	12.4	15.3	2,453
			IV	17.4			12.4	15.3	2,478	
LCS-70RN-FF654			2.5 x 6 x 54	III			16.5	13.4	15.2	2,502
			IV	17.4			13.4	15.2	2,527	
LCS-70RN-FF660		2.5 x 6 x 60	III	16.5	14.4	15.0	2,563			
	IV	17.4	14.4	15.0	2,588					
LCS-7CRN-FF642	7,000	15.5-77.4	2.5 x 6 x 42	III	0	16.5	11.6	15.5	2,403	
			IV	17.4			11.6	15.5	2,428	
LCS-7CRN-FF648			2.5 x 6 x 48	III			16.5	12.4	15.3	2,453
			IV	17.4			12.4	15.3	2,478	
LCS-7CRN-FF654			2.5 x 6 x 54	III			16.5	13.4	15.2	2,502
			IV	17.4			13.4	15.2	2,527	
LCS-7CRN-FF660		2.5 x 6 x 60	III	16.5	14.4	15.0	2,563			
	IV	17.4	14.4	15.0	2,588					
LCS-85RN-FF742	8,500	20–84	2.5 x 7 x 42	III	0	16.5	11.0	15.0	2,599	
			IV	17.9			11.0	15.0	2,624	
LCS-85RN-FF748			2.5 x 7 x 48	III			16.5	11.9	14.8	2,649
			IV	17.9			11.9	14.8	2,674	
LCS-85RN-FF754			2.5 x 7 x 54	III			16.5	12.9	14.7	2,700
			IV	17.9			12.9	14.7	2,725	
LCS-85RN-FF760		2.5 x 7 x 60	III	16.5	14.0	14.5	2,754			
	IV	17.9	14.0	14.5	2,778					
NSQ-11RN-FH748	11,000	20–86	3 x 7 x 48	IV	0	18.7	9.0	7.6	3,960	
NSQ-14RN-FH848	14,000	18–88	3 x 8 x 48	IV	0	19.2	9.9	9.3	4,377	

¹ Opening range is to inside of forks.

Minimum Truck Carriage Width

Model Number	Body Width (in)	Minimum Truck Carriage Width (in)
LCS-25RN/35RN	36/41	29
LCS-50RN	41	33
LCS-70/85RN ITA III	50	36
LCS-70/85 ITA IV	50	39.5
NSQ-11/14RN	52/64	39/56

Recommended Hydraulic Supply

Model Number	Flow (gpm)	Max psi
LCS-25RN thru LCS-85RN	12	2,500
NSQ-11/14RN	24	2,250

Choose Long Reach for serviceability, value, and custom design

Multi-Pallet Handlers
 Fork Positioners
 Integral Carriages
 Paper Roll Clamps
 Lateral Clamps

Carton Clamps
 Push-Pulls
 Rotators
 Custom Design

21433 SW Oregon Street
 Sherwood, Oregon 97140-9799 USA
 Toll free: (800) 285-7000
 Phone: (503) 625-2560
 Fax: (503) 625-7269
 Email: marketing@alliedsystems.com
 www.alliedsystems.com/Longreach

LONG REACH[®]
 A Division of Allied Systems Company