

Long Reach Carton Clamps

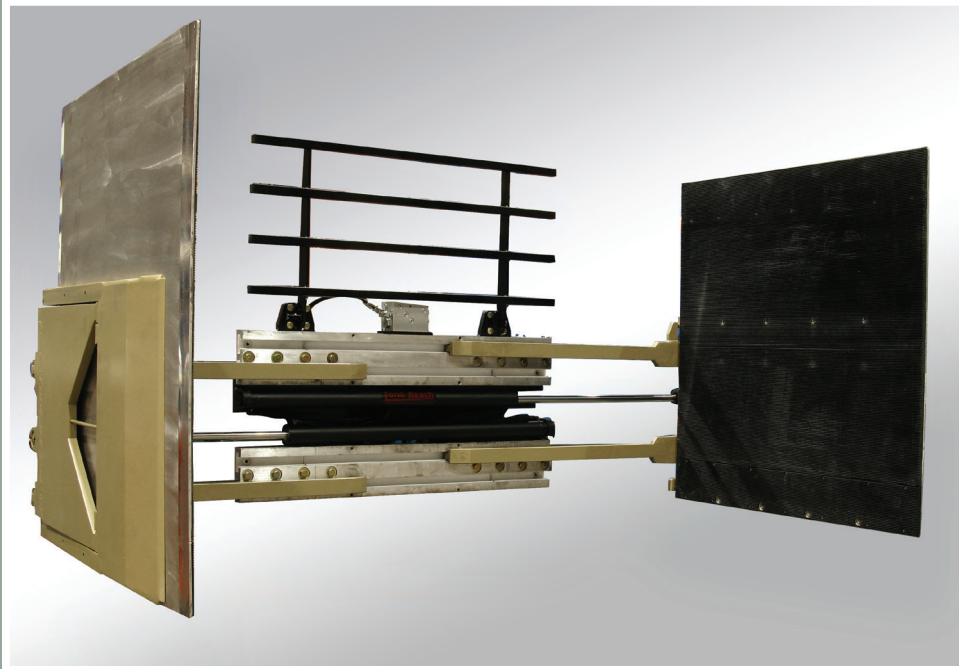

Palletless handling systems save on shipping weight, volume, and the cost of the pallets.

Benefits

- Eliminate load support
- Securely transport clamped loads at higher speeds than palletized loads
- Securely place and retrieve loads in high stacking applications
- Pick one or more layers from unit loads for easy order selection
- Prevent product damage caused by broken pallets

Features

- Ideal for handling appliances and tight breakout situations. Long Reach articulating arm carton clamps knife between tightly-stacked cartons without disturbing any adjacent rows.

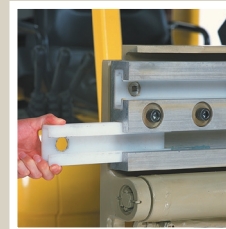
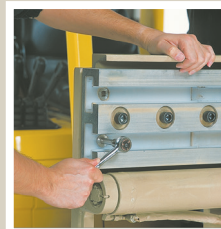

- All Long Reach carton clamps feature clean, grease-free handling and Repair-N-Place serviceability
- The clamp pad pivots in front of the centerline, reducing the chance of the lower front cases bridging or slipping.
- Thin-arm profile along the entire arm allows easy entry. With a tip thickness of only 0.38" (9.7mm) and a rear arm thickness as little as 2.7" (68.6mm), the Long Reach articulating arm design is the thinnest on the market.

LCC Articulating Arm Carton Clamps

- ◆ Thin-arm profile along the entire arm allows ease of entry
- ◆ For tight breakout situations; ideal for handling appliances
- ◆ Sideshift improves productivity

Sideshifting Carton Clamps, 2 Functions

Model Number	Capacity lbs @ LC (in)	Opening Range (in)	Arm Size L x H (in)	Mounting Class	Lost Load AET (in)	HCG (in)	VCG (in)	Weight (lb)
LCC-15NS-B3048	1,500 @ 15		30 x 48			8.3	14.4	1,130
LCC-15NS-B4048	1,500 @ 20		40 x 48			11.2	14.5	1,280
LCC-15NS-B4248	1,500 @ 21		42 x 48			11.9	14.6	1,320
LCC-15NS-B4448	1,500 @ 22	22-76	44 x 48	II or III	5.0	12.5	14.6	1,355
LCC-15NS-B4648	1,500 @ 23		46 x 48			13.2	14.6	1,390
LCC-15NS-B4848	1,500 @ 24		48 x 48			13.7	14.5	1,410
LCC-15NS-B5448	1,500 @ 27		54 x 48			15.9	14.6	1,555
LCC-2ANS-B4048	2,500 @ 20		40 x 48			11.5	14.6	1,241
LCC-2ANS-B4248	2,500 @ 21		42 x 48			12.2	14.6	1,280
LCC-2ANS-B4448	2,500 @ 22	19-65	44 x 48	II or III	5.0	12.8	14.6	1,315
LCC-2ANS-B4648	2,500 @ 23		46 x 48			13.5	14.6	1,350
LCC-2ANS-B4848	2,500 @ 24		48 x 48			14.0	14.5	1,370
LCC-25NS-B3048	2,500 @ 15		30 x 48			8.3	14.4	1,130
LCC-25NS-B4048	2,500 @ 20		40 x 48			11.2	14.5	1,285
LCC-25NS-B4248	2,500 @ 21		42 x 48			11.8	14.5	1,325
LCC-25NS-B4448	2,500 @ 22	22-76	44 x 48	II or III	5.0	12.5	14.6	1,360
LCC-25NS-B4648	2,500 @ 23		46 x 48			13.2	14.6	1,395
LCC-25NS-B4848	2,500 @ 24		48 x 48			13.7	14.5	1,415
LCC-25NS-B5448	2,220 @ 27		54 x 48			15.9	14.7	1,540
LCC-35NS-B4048	3,500 @ 20		40 x 48			11.5	14.7	1,330
LCC-35NS-B4248	3,500 @ 21		42 x 48			12.1	14.7	1,360
LCC-35NS-B4448	3,500 @ 22	22-76	44 x 48	II or III	5.0	12.8	14.8	1,400
LCC-35NS-B4648	3,500 @ 23		46 x 48			13.4	14.8	1,435
LCC-35NS-B4848	3,500 @ 24		48 x 48			14.1	14.8	1,470
LCC-35NS-B5448	3,110 @ 27		54 x 48			16.2	14.9	1,585

Shaded items are usually in stock.

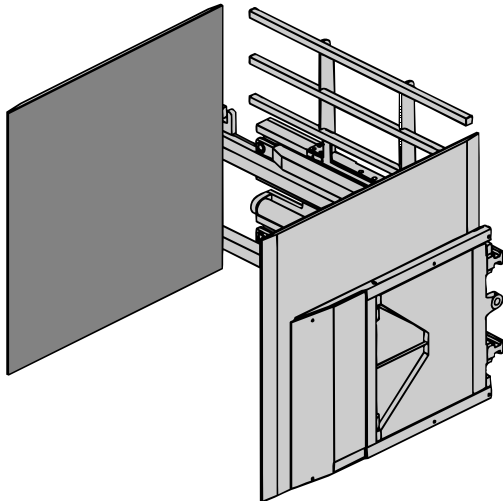

Recommended Hydraulic Supply

Model Number	Flow (gpm)	Max psi
All Models	7-9	2,500

Hydraulic flow less than minimum may reduce operating speed and/or cause irregular arm movement. Higher flow may result in heat build-up, erratic operation and shortened hydraulic system life.

Optional Mounting Equipment

Shaft- or pin-type mounting brackets

ITA dual mounting brackets –
Quick-Change: Class II & III

Minimum Truck Carriage Width

Model Number	Body Width (in)	Minimum Truck Carriage Width (in)
LCC-2A	36	30
LCC-15/25/35	41	35

Carton Clamp Options

Height extensions of arm and backrest

Steel

Rubber

Sight holes in steel extensions

Arms: Less than 48" high

From 36" minimum to 48" high

Less than 36" high

Pad lengths not shown

Bottom wear strips

Leading edge/nose protection strips

7" high replaceable pad on bottom of arm

Modified opening ranges

LCC ADJUST-A-FORCE™ Carton Clamps

- ◆ Provides “soft touch” to handle the most delicate products
- ◆ Exclusive spring plate arms distribute force evenly over load support area
- ◆ Fine tune the clamp for fragile products by adjusting fulcrum levers in each arm
- ◆ Beveled contact pad tips and smooth outer surfaces provide a thin arm profile and easy entry between loads

Sideshifting Carton Clamps, 2 Functions

Model Number	Capacity lbs @ LC (in)	Opening Range (in)	Arm Size L x H (in)	Mounting Class	Lost Load AET (in)	HCG (in)	VCG (in)	Weight (lbs)
LCC-25NS-S4048	2,500 @ 20	21.0–75.5	40 x 48	II	5.0	13.0	13.6	1,181
LCC-25NS-S4248	2,500 @ 21		42 x 48			13.5	13.7	1,200
LCC-25NS-S4648	2,500 @ 23		46 x 48			14.3	13.8	1,228
LCC-25NS-S4848	2,500 @ 24		48 x 48			15.5	13.8	1,294
LCC-35NS-S4048	3,500 @ 20	21.0–75.5	40 x 48	II	5.0	12.6	13.5	1,223
LCC-35NS-S4248	3,500 @ 21		42 x 48			13.1	13.5	1,242
LCC-35NS-S4648	3,500 @ 23		46 x 48			13.9	13.7	1,270
LCC-35NS-S4848	3,500 @ 24		48 x 48			15.1	13.7	1,336
LCC-35NS-S5248	3,230 @ 26	21.0–75.5	52 x 48	II	5.0	16.0	13.8	1,364
LCC-35NS-S5448	3,110 @ 27		54 x 48			1.0	13.8	1,490
LCC-35NS-S4054	3,500 @ 20		40 x 54			13.2	14.5	1,255
LCC-35NS-S4254	3,500 @ 21		42 x 54			13.8	14.6	1,275
LCC-35NS-S4654	3,500 @ 23	21.0–75.5	46 x 54	II	5.0	14.6	14.9	1,310
LCC-35NS-S4854	3,500 @ 24		48 x 54			15.6	14.9	1,375
LCC-35NS-S5254	3,230 @ 26		52 x 54			16.5	15.0	1,407
LCC-35NS-S5454	3,110 @ 27		54 x 54			18.5	15.0	1,534
LCC-35NS-S4060	3,500 @ 20	21.0–75.5	40 x 60	II	5.0	13.3	15.6	1,288
LCC-35NS-S4260	3,500 @ 21		42 x 60			13.9	15.8	1,310
LCC-35NS-S4660	3,500 @ 23		46 x 60			14.8	16.1	1,345
LCC-35NS-S4860	3,500 @ 24		48 x 60			16.0	16.1	1,415
LCC-35NS-S5260	3,230 @ 26	21.0–75.5	52 x 60	II or III	5.0	17.0	16.3	1,450
LCC-35NS-S5460	3,110 @ 27		54 x 60			18.9	16.3	1,580
LCC-50NS-S4248	5,000 @ 21		42 x 48			13.0	13.5	1,265
LCC-50NS-S4648	5,000 @ 23		46 x 48			13.7	13.6	1,295
LCC-50NS-S4848	5,000 @ 24	21.0–75.5	48 x 48	II or III	5.0	14.9	13.6	1,360
LCC-50NS-S4060	5,000 @ 20		40 x 60			13.2	15.5	1,316
LCC-50NS-S4260	5,000 @ 21		42 x 60			13.7	15.7	1,334
LCC-50NS-S4660	5,000 @ 23		46 x 60			14.6	16.0	1,369
LCC-50NS-S4860	5,000 @ 24	21.0–75.5	48 x 60	II or III	5.0	15.8	16.0	1,438

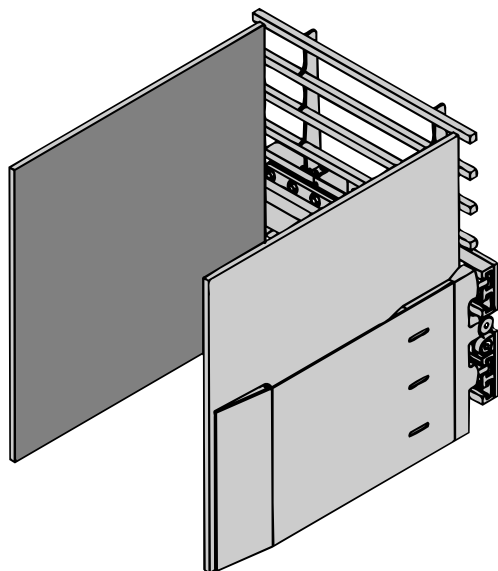

Recommended Hydraulic Supply

Model Number	Flow (gpm)	Max psi
All Models	7–9	2,500

Hydraulic flow less than minimum may reduce operating speed and/or cause irregular arm movement. Higher flow may result in heat build-up, erratic operation and shortened hydraulic system life.

Minimum Truck Carriage Width

Model Number	Body Width (in)	Minimum Truck Carriage Width (in)
LCC-25/35/50	41	35

White Goods Carton Clamp

- ◆ Designed for handling one to four unit loads at a time
- ◆ Sideshift improves productivity

Sideshifting Carton Clamps, 2 Functions

Model Number	Capacity lbs @ 24"	Opening Range (in)	Arm Size L x H (in)	Mounting Class	Lost Load AET (in)	HCG (in)	VCG (in)	Weight (lbs)
LCC-2CNS-B3454	2,500	21.9–83.6	34 x 54	II	5.1	9.3	15.0	1,255

Forward Tipping Clamp

- ◆ 90 degree forward upending function
- ◆ Sideshift improves productivity

Sideshifting Carton Clamps, 2 Functions

Model Number	Capacity lbs @ 24"	Opening Range (in)	Arm Size L x H (in)	Mounting Class	Lost Load AET (in)	HCG (in)	VCG (in)	Weight (lbs)
LCC-2AUS-B3432	1,750	19–65	34 x 32	II	11.7	11.6	13.6	2,200

Other arm sizes/opening ranges are available. Consult factory.

Mini-Arm Appliance Clamps

- ◆ Designed to handle large carton items such as washers, dryers, freezers and furniture

Sideshifting Appliance Clamp, 2 Functions

Model Number	Capacity lbs @ 18"	Opening Range (in)	Arm Size L x H (in)	Mounting Class	Lost Load AET (in)	HCG (in)	VCG (in)	Weight (lb)
LCC-25NS-M1540			15 x 40			5.7	17.0	1,150
LCC-25NS-M1560	2,500	24.1-78.9	15 x 60	II	7.0	6.2	27.0	1,270
LCC-25NS-M1572			15 x 72			6.9	33.0	1,340

Double-Wide Carton Clamp

- ◆ Designed for handling one or two unit loads at a time

Sideshifting Carton Clamps, 2 Functions

Model Number	Capacity lbs @ 24"	Opening Range (in)	Arm Size L x H (in)	Body Width	Mounting Class	Lost Load AET (in)	HCG (in)	VCG (in)	Weight (lbs)
LCC-1DNS-B4848	1,500	36 – 102	48 x 48	48	II	5.0	12.6	14.5	1,568
LCC-2DNS-B4848	2,500	36 – 102	48 x 48	52	II	5.1	12.5	14.5	1,590
LCC-3DNS-B4848	3,500	26 – 102	48 x 48	62	II	5.0	12.4	14.7	1,690

Razor-Flex Arm Design

- ◆ Thin arm profile designed to handle large loads
- ◆ Larger capacity available

Sideshifting Carton Clamp, 2 Functions

Model Number	Capacity lbs @ 24"	Opening Range (in)	Arm Size L x H (in)	Mounting Class	Lost Load AET (in)	HCG (in)	VCG (in)	Weight (lb)
LCC-25NS-F3030			30 x 30			6.3	10.2	880
LCC-25NS-F3430	2,500	17.9–67.6	34 x 30	II	5.75	6.3	10.2	905
LCC-25NS-F3048			30 x 48			6.4	10.2	1,160

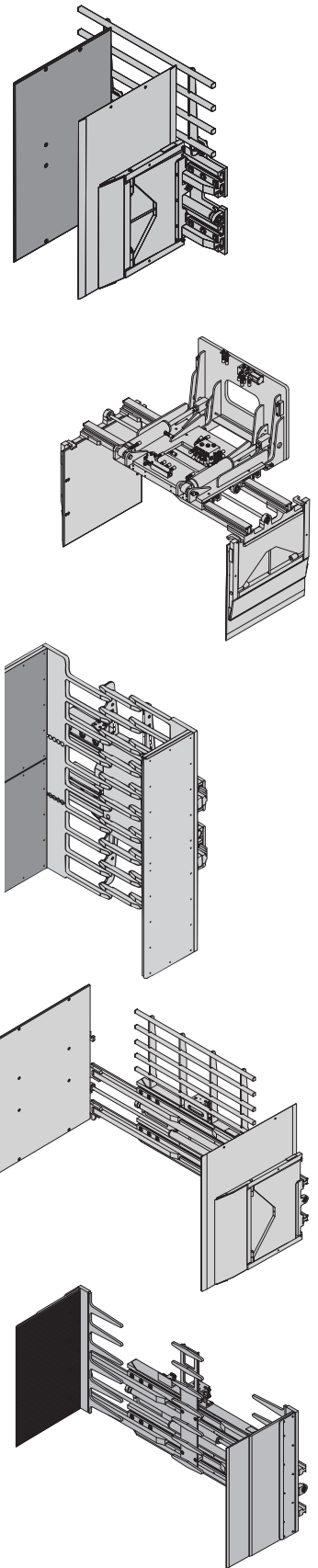

Choose Long Reach for serviceability, value, and custom design

Multi-Pallet Handlers
Fork Positioners
Integral Carriages
Paper Roll Clamps
Lateral Clamps

Carton Clamps
Push-Pulls
Rotators
Custom Design

21433 SW Oregon Street
Sherwood, Oregon 97140-9799 USA
Toll free: (800) 285-7000
Phone: (503) 625-2560
Fax: (503) 625-7269
Email: marketing@alliedsystems.com
www.alliedsystems.com/Longreach

LONG REACH[®]
A Division of Allied Systems Company

87-569 5/18