

Carton Clamp Camber Adjustment

Installation Instructions

- 1) Carton clamp arms must be inside the frame as shown in Figure 1-1. Measurements T and B are taken at the pivot point (center of pad).
- 2) Total camber is T minus B.
- 3) Each 1/16" spacer (part number 156057) will increase or decrease camber 1/8" on a 48" high pad.
- 4) To increase camber, add one or more 1/16" spacers between the pad and the lower platen support.
- 5) To decrease camber, add one or more 1/16" spacers between the pad and the upper platen support.
- 6) Use existing bolts if one spacer is used. Increase bolt length if two or three spacers are used.

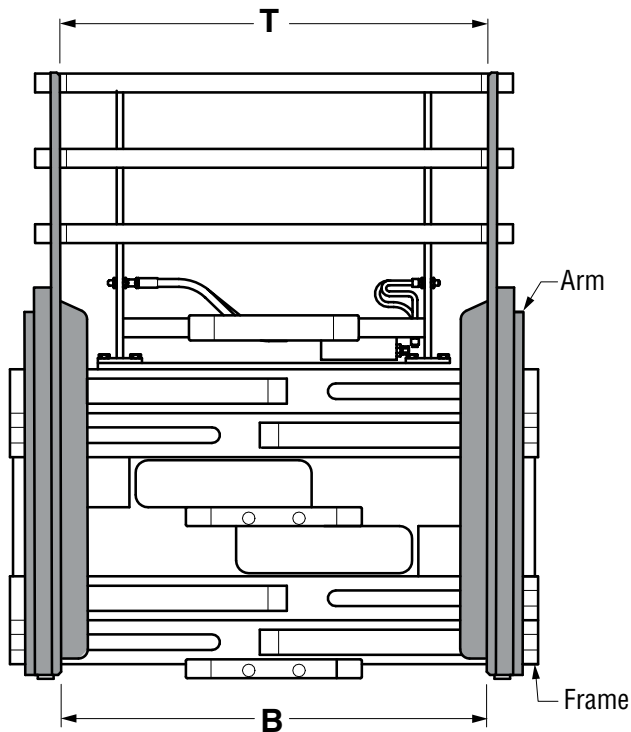

Figure 1-1

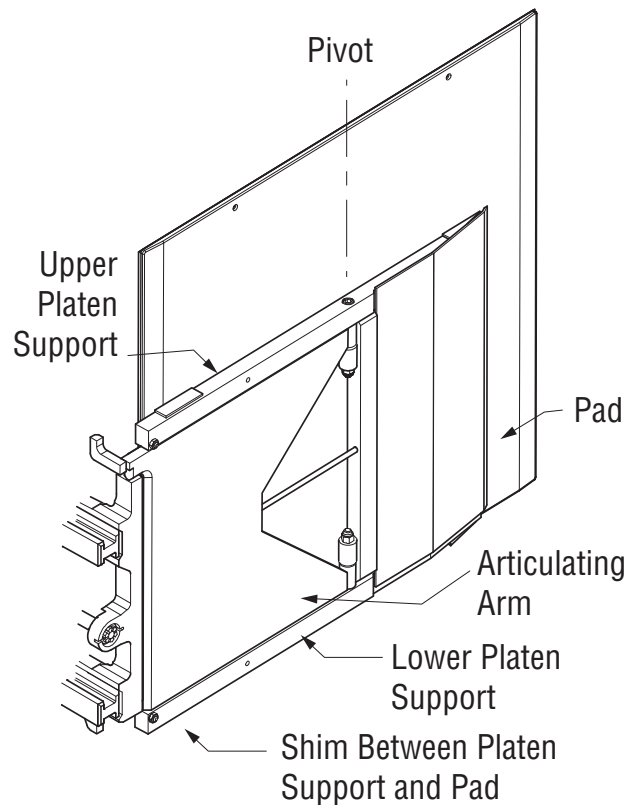

Figure 1-2