



Installation, Maintenance and Service Manual LPF, LPB

Load Push Attachments

THIS PAGE WAS INTENTIONALLY LEFT BLANK

TABLE OF CONTENTS

SECTION 1 NAMEPLATE LOCATION..	4	SECTION 5 MAINTENANCE	28
SECTION 2 MODEL INFORMATION....	5	5.1 Maintenance Schedule Daily:.....	28
SECTION 3 SAFETY SUMMARY	7	5.2 Torque Specifications	28
3.1 Safety Information.....	7	SECTION 6 SERVICE PROCEDURES...	31
3.2 Product Modifications.....	7	6.1 Attachment Handling Safety.....	31
3.3 Safety Regulations.....	7	6.2 General	32
3.4 Safety Symbols	7	6.3 Pivot Pin Installation and Removal.	33
3.5 Labeling	8	6.4 Cylinder Removal.....	33
3.6 Training	8	6.5 Cylinder Installation.....	34
3.7 Personnel Safety.....	9	6.6 Gripper Pad Removal.....	35
3.8 Pre-start Checks	10	6.7 Gripper Pad Installation	36
3.9 Operation Warnings	10	6.8 Faceplate Angle Adjustment	36
3.10 Hydraulic Hazards	10	6.9 Platen Removal.....	37
3.11 Electrical Hazards	11	6.10 Platen Installation.....	37
3.12 Maintenance Warnings	11	6.11 Platen Repositioning	40
3.13 Load Handling.....	12	6.12 Platen Disassembly.....	41
3.14 Load Positioning.....	13	6.13 Platen Reinstallation	42
3.15 Operator's Controls	14	6.14 Platen Lubrication	42
3.16 Clamp Open Control	15	6.15 Mechanism Disassembly	42
3.17 Industry Standards.....	16	6.16 Bushing Replacement.....	45
SECTION 4 INSTALLATION AND RE-		6.17 Mechanism Reassembly.....	45
MOVAL	18		
4.1 Truck Requirements	18		
4.2 Hydraulics	20		
4.3 Attachment Handling Safety.....	20		
4.4 Attachment Installation, Fork Mounted (LPF Only)	22		
4.5 Attachment Removal, Fork Mounted (LFP Only)	24		
4.6 Attachment Installation, Dedicated (LP)	24		
4.7 Attachment Removal, Dedicated (LP)	27		

SECTION 1 NAMEPLATE LOCATION

Notice

When you receive your attachment, locate the Long Reach nameplate (upper left corner on the body or front of base unit) and record the information in the space provided on the bottom of this page. If the nameplate is missing, look for the serial number stamped directly into the frame at the original location and consult factory for replacement.

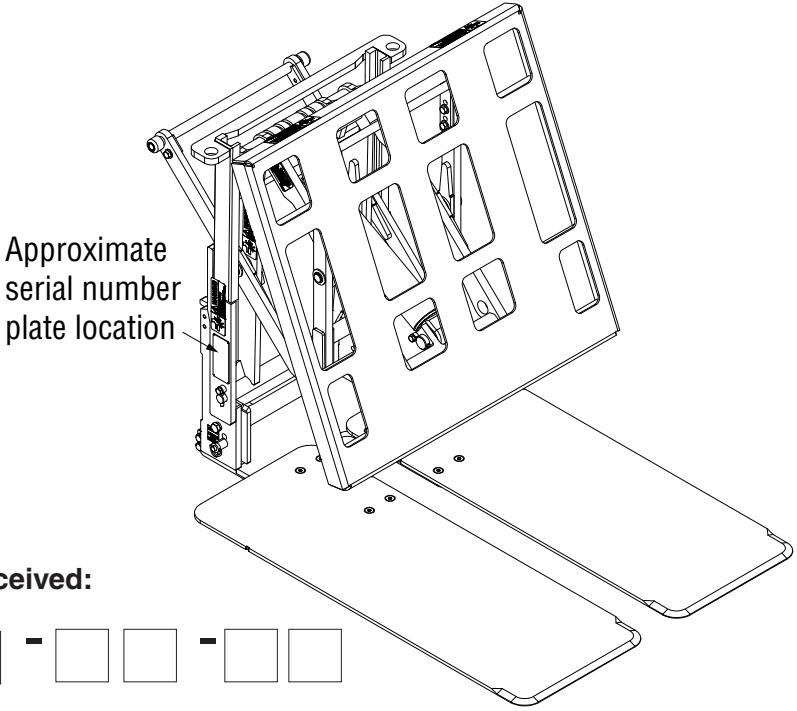

Date Received:

		-			-		
--	--	---	--	--	---	--	--

LONG REACH A Division of Allied Systems Company		21433 SW Oregon Street Sherwood OR 97140 USA www.alliedsystems.com	2500005 rF
MODEL NO.:			SERIAL NO.:
CAPACITY AT LOAD CENTER:	<input type="text"/> KG @ <input type="text"/> MM <input type="text"/> (LBS) @ <input type="text"/> (IN)	MASS: <input type="text"/> KG <input type="text"/> (LBS)	AET: <input type="text"/> MM <input type="text"/> (IN)
MAXIMUM HYDRAULIC PRESSURE:	<input type="text"/> BAR <input type="text"/> (PSI)	FLOW: <input type="text"/> L/min <input type="text"/> (GPM)	HCG: <input type="text"/> MM <input type="text"/> (IN)
DATE:			VCG: <input type="text"/> MM <input type="text"/> (IN)
SEE TRUCK NAMEPLATE FOR COMBINED TRUCK & ATTACHMENT CAPACITY			

QUICK PARTS LOCATION GUIDE

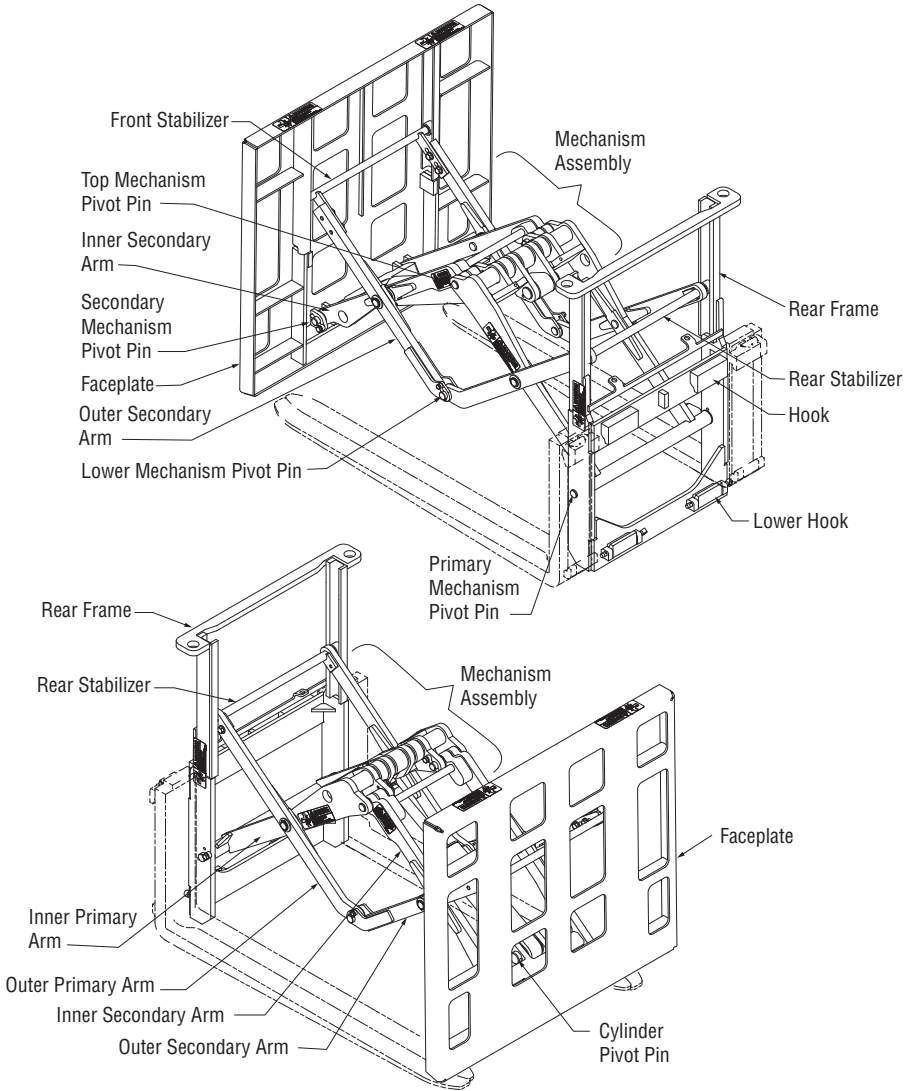

SECTION 2 MODEL NUMBER INFORMATION

LP Series Model Number:

Each attachment is identified by a model number and a serial number located on the name plate attached to the unit prior to shipment. Long Reach's model numbers are designed to describe how an attachment is equipped. The guide below illustrates the information that is represented in a multi-digit model number. Always include model and serial number when ordering parts or requesting service information.

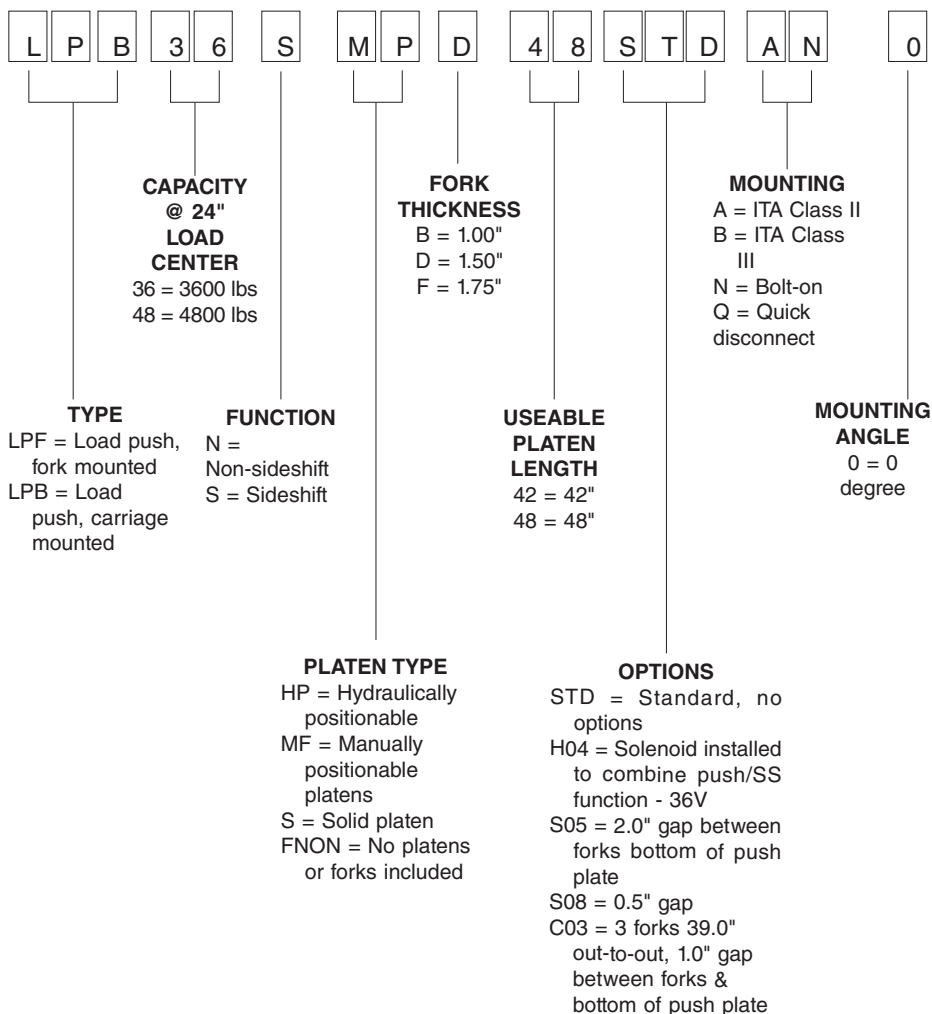

SECTION 3 SAFETY SUMMARY

3.1 Safety Information

Safety is Everyone's Responsibility

Whether you are new on the job or a seasoned veteran, these safety tips may prevent injury to you, to others, or to the materials you are handling. Always be alert, watch out for others, and follow these suggestions:

Attachments handle material, not people.

Safety starts with common sense, good judgement, properly maintained equipment, careful operation, and properly trained operators.

The safety instructions and warnings, as documented in this manual and shipped with the machine, provide the most reliable procedures for the safe operation and maintenance of your Long Reach attachment. It's your responsibility to see that they are carried out.

3.2 Product Modifications

Any alterations to the product, that have not been approved by Allied Systems Company or use of any non-OEM replacement parts will void the warranty, and may introduce serious safety hazards. Any non-OEM parts used, or any alterations made are done so at your own risk to personnel safety. This includes the addition of accessories and attachments not manufactured by Allied Systems Company.

3.3 Safety Regulations

Know your company's safety rules. Some companies have site-specific directions and procedures. The methods outlined in your operator's manual provide a basis for safe operation of the machine. Because of special conditions, your company's material handling procedures may be somewhat different from those shown in this manual.

3.4 Safety Symbols

The following terms define the various precautions and notices:



DANGER

Indicates a hazardous situation which, if not avoided, will result in death or serious injury. Carefully read the message that follows to prevent serious injury or death.



WARNING

Indicates a hazardous situation which, if not avoided, could result in death or serious injury. Carefully read the message that follows to prevent serious injury or death.

CAUTION

Indicates a hazardous situation which, if not avoided, could result in minor or moderate injury, or equipment damage or void the machine warranty. Carefully read the message that follows to prevent minor or moderate injury.

Notice

Describes information that is useful but not safety related.

WARNING

Multiple hazards.

Ignoring safety warnings may cause equipment damage, personal injury or death.

All possible safety hazards cannot be foreseen and included in this manual. The operator must always be alert to possible hazards that could endanger personnel or damage the equipment.

3.5 Labeling

- Change capacity, operation, and maintenance instruction plates, tags, or decals when a forklift truck is equipped with an attachment. If the truck is equipped with front-end attachments other than factory installed attachments, truck must be marked to identify the attachments and show the approximate weight of the truck and attachment combination at maximum elevation with load laterally centered.

3.6 Training

- Make sure all operators are trained in the fork and attachment adaptation, operation, and use limitations. Retrain an operator if a new attachment is added to the forklift. Consult the operator's manual for instructions on how to use the new equipment.
- Know the mechanical limitations of your forklift.
- Modifications or additions that affect capacity or safe operation must have prior written approval from the forklift truck manufacturer. Capacity, operation, and maintenance instruction plates, tags, or decals shall be changed accordingly.
- Never use free rigging for a below-the-forks lift. It could affect the capacity and safe operation of a lift truck.

3.7 Personnel Safety

- When removing or installing dismountable attachments always keep hands and feet free from dangerous positions or pinch points. Never leave a dismounted attachment in a dangerous position.
- Keep hands, feet, long hair and clothing away from power-driven parts. Do not wear loose fitting clothing or jewelry while performing maintenance and lubrication in these areas.
- Never jump on or off the machine.
- Never stand on top of material being raised, lowered, or transported. (Figure 3-1)

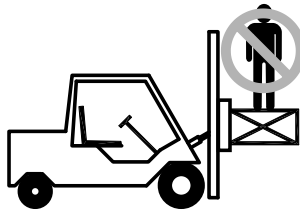

Figure 3-1,

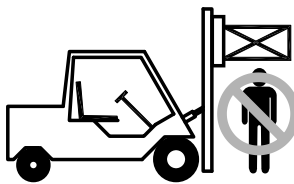

Figure 3-2,

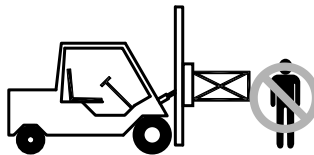

Figure 3-3,

- Never use the attachment or its load to support a man-carrying device.
- Never allow anyone under a load or under the carriage. (Figure 3-2)
- Never stand in front of or beside an attachment that is being operated. Never allow another person to approach an attachment that is being operated. (Figure 3-3)
- Never leave an attachment or load in an elevated position.
- Never reach through the mast of the truck. Keep all parts of the body within the driver's compartment.

- Always operate an attachment from the operator's seat, never while standing next to the lift truck.
- Do not allow riders on the truck at any time.
- Always use reverse when carrying a load that impedes full vision. Watch for pedestrians when transporting.
- Always use personal protective equipment (PPE) appropriate to the situation.

3.8 Pre-start Checks

- Check your equipment before you operate it. If anything looks wrong, unusual or different, report it before using the attachment.
- Do not operate this machine if you know of malfunctions, missing parts, and/or mis-adjustments. These situations can cause or contribute to an accident or damage to the machine. Stop the machine immediately if problems arise after starting.
- Check to make sure the attachment on your truck is the same as on the truck capacity plate.
- Check for hydraulic leaks and cracked hoses or fittings. Check the hydraulic oil level in the lift truck hydraulic reservoir.
- All electrical cables and connectors must be in good condition. Use caution in wet weather to avoid danger from electrical shock.
- Always check the attachment for proper fit and engagement of the truck carriage.

3.9 Operation Warnings

- You must be trained to operate this equipment prior to operation. Be extremely careful if you do not normally operate this machine. Reorient yourself to the machine before starting, then proceed slowly.
- Always operate an attachment from the driver's seat.
- Always lower the attachment if you need to leave the lift truck. A lift truck supporting a load requires your full attention.

3.10 Hydraulic Hazards



Injection hazard.

Infection and gangrene will result when hydraulic oil penetrates the skin. See a doctor immediately to prevent loss of limb or death.

Use a piece of cardboard to check for hydraulic leaks.

- Wear personal protective equipment, such as gloves and safety glasses, whenever servicing or checking a hydraulic system.
- Assume that all hydraulic hoses and components are pressurized. Relieve all hydraulic pressure before disconnecting any hydraulic line.
- Never try to stop or check for a hydraulic leak with any part of your body; use a piece of cardboard to check for hydraulic leaks.

3.11 Electrical Hazards



WARNING

Electrocution hazard.

Contact with energized equipment may result in injury or death and will damage equipment.

Remain at least 25 feet from high voltage electrical wires.

- All electrical cables and connectors must be in good condition (free of corrosion, damage, etc). Use caution in wet weather to avoid danger from electrical shock. Never attempt electrical testing or repair while standing in water.
- Do not wear electrically conductive jewelry, clothing, or other items while working on the electrical system.

3.12 Maintenance Warnings

Maintenance, lubrication and repair of this machine can be dangerous unless performed properly. You must have the necessary skills and information, proper tools and equipment. Work in a method that is safe, correct, and meets your company's requirements.

- Do not attempt to make adjustments, or perform maintenance or service unless you are authorized and qualified to do so.
- Include attachments in a scheduled maintenance and inspection program. Tailor inspection steps to the attachment.
- Unless specified in service procedures, never attempt maintenance or lubrication procedures while the machine is moving or the engine is running.
- Always perform all maintenance and lubrication procedures with the machine on level ground, parked away from traffic lanes.

Notice

Local laws and regulations may require that additional safety measures be taken.

- Never rely on the hydraulic system to support any part of the machine during maintenance or lubrication. Never stand under a component that is supported only by the hydraulics. Make sure it is resting on its mechanical stops or appropriate safety stands.
- Use caution when working around hot fluids. Always allow lubricating and hydraulic oils to cool before draining. Burns can be severe.
- Use extreme caution when using compressed air to blow parts dry. The pressure should not exceed 30 psi (208 kPa) at the nozzle. Never use compressed air on yourself. Air pressure penetrating your skin can be fatal.



WARNING

Suffocation hazard.

Engine exhaust fumes can cause death.

Remove the exhaust fumes from the area with an exhaust pipe extension, or use ventilation fans and open shop doors to provide adequate ventilation.

- Before disconnecting hydraulic lines, be sure to lower all loads and relieve all hydraulic pressure. The load could fall on you, or escaping hydraulic oil could cause severe personal injury.
- Prevent personal injury or equipment damage by using a lifting device with a lifting capacity greater than twice the weight of any equipment to be lifted.

3.13 Load Handling

- Treat an unloaded forklift with an attachment as partially loaded.



CAUTION

Equipment overload hazard.

Injury or equipment damage may result if the capacity of the truck and attachment combined are less than the attachment capacity.

Consult truck nameplate for truck capacity with an attachment installed.

- Never overload the attachment. Refer to the attachment nameplate for the rated capacity of the attachment. Refer to the truck nameplate for the maximum net working capacity of the truck/attachment combination. Never use a load to support or move another object. Doing so can easily exceed the holding capacity of the attachment.
- Always check loads to be handled. Correct loads that are broken, unbalanced, loose, or too heavy.

- Never lift, lower, side shift, pivot, rotate, or tilt loads while traveling. Repositioning loads while traveling affects the stability of the truck and may impede vision or clearances.
- Do not use an attachment to open or close boxcar doors. Doing so can severely damage the attachment and cause loss of warranty. Damage to clamp arms may result in product damage.
- Do not carry loose items or unsupported loads on top of a clamped load.
- Never use chains, cables, or other devices in conjunction with an attachment for load handling.
- Never clamp loads other than what the attachment was designed to handle.
- Always carry cylindrically shaped loads in the vertical position, not the horizontal.
- Always clamp loads with the contact pads, if applicable, not the arm or arm base.
- Never rotate a load that is off center to the centerline of rotation. Severe damage to the rotator could result.
- Always ensure that the load is the same width as the pallet and neatly stacked when using a carton clamp.

3.14 Load Positioning

- Be accurate in load placement. It's important to know what the load will do when it's released.
- Always carry loads as close to the floor as possible, consistent with the surface being traversed. Scraping or bumping the floor surface with the load or the attachment can severely damage the attachment and cause product damage. The mast should be tilted back.
- Always keep the load positioned as close as possible to the horizontal center of the lift truck.
- Always back down ramps or inclines. Driving forward down a ramp or incline with a clamped load will lessen the stability of the truck. (Figure 3-4)

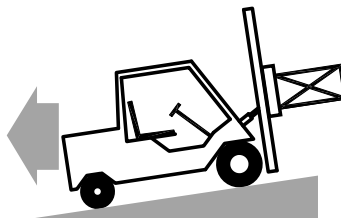

Figure 3-4,

- Do not cross dock boards or dock levelers with the attachment or carriage fully lowered. Ramming the front or rear of the attachment against a dock board can cause severe damage.
- Limit lift truck movement to a minimum when high stacking. Limit sideshift movement to a minimum when high stacking.
- Always be observant when high stacking. Look for poorly stacked loads, overhead obstacles, broken cartons, or damaged products in the stack.
- Travel slowly around corners. Sound horn on blind corners. Be careful of tail swing and overhead clearances. Watch in all directions. Avoid sudden stops.

3.15 Operator's Controls

Some lift trucks are equipped with a single lever to control both hoist and tilt functions, others have separate levers for each function. Refer to your lift truck manual for more information.

For clarity, the direction of arm movement is shown on the control handle. To move the arms in the direction shown, pull the handle towards the operator. To move the arms in the opposite direction, the push the handle away from the operator. (Figure 3-5)

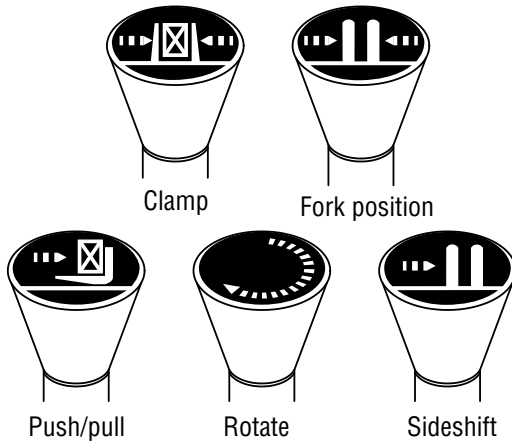

Figure 3-5, Operator controls

Lifting speed is controlled by the speed of the engine and the position of the control lever. Engine speed has no effect on lowering speed.

Before going on the job, shift the truck control levers one way and then the other to determine which direction the attachment moves when the levers are shifted. Make sure the attachment moves smoothly throughout its travel, without binding or pinching hoses.



CAUTION

Equipment damage hazard.

Injury or equipment damage may result if the attachment does NOT operate smoothly.

Do not take malfunctioning equipment on the job. Check with your supervisor about needed repairs.

3.16 Clamp Open Control

Effective October 7, 2010, safety standard ANSI/ITSDF B56.1, Section 7.25.7 covers all lift trucks with a load bearing clamp (paper roll clamp, carton clamp, etc.), and requires the driver to make two distinct motions before opening or releasing the clamp. For example, you must press a switch and then move a lever to unclamp the load. This requirement applies to new and used attachments being mounted on trucks which shipped from the factory after October 7, 2010, and is a recommended feature to be installed on dealer orders and existing applications.



WARNING

Load loss hazard.

Injury or equipment/load damage may result if a fork positioner attachment is used to clamp a load. The fork positioner does not have enough clamping force to safely hold a load.

Always support the load with the forks. Do not use fork positioning attachments as clamps.

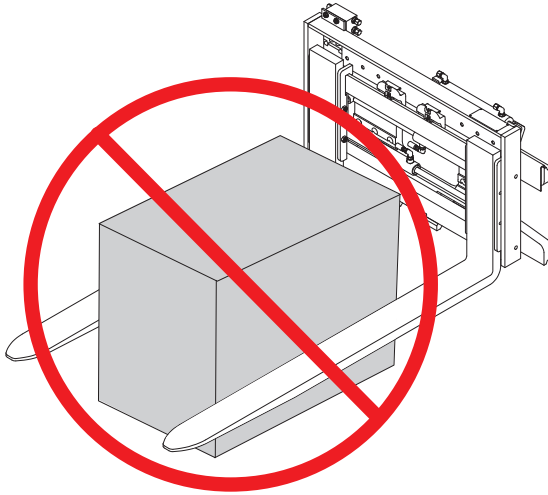

Figure 3-6, Do Not Clamp

3.17 Industry Standards

ANSI/ITSDF B56.1-2016 is the published sequence and direction standard for lever- and hand-type controls.

Notice

The chart on the following page shows industry standards. Your equipment may be different. If you do not routinely operate this equipment, refresher training is recommended. You must reacquaint yourself with this manual and the equipment before starting, and then proceed slowly.

Special controls such as automatic devices should be identified, preferably according to the recommendations in Figure 3-7.

When a function is controlled by a pair of push buttons, they should operate in the same sense as the lever controls. For example, pushing a button located to the rear (relative to the operator's position) should serve the same function as moving a control lever to the rear.

Function	Direction of motion	
	Load	Operator's hand on control handle, facing the load*
Hoist	Up Down	Rearward or up Forward or down
Reach	Retract Extend	Rearward or up** Forward or down
Tilt	Rearward Forward	Rearward or up** Forward or down
Sideshift	Right Left	Rearward or up Forward or down
Push-pull	Rearward Forward	Rearward or up** Forward or down
Rotate, lateral	Clockwise Counterclock- wise	Rearward or up Forward or down
Rotate, longitude	Rearward Forward	Rearward or up Forward or down
Load stabilizer	Down Up	Rearward or up Forward or down
Swing	Right Left	Rearward or up Forward or down
Slope	Clockwise Counterclock- wise	Rearward or up Forward or down
Fork position	Together Apart	Rearward or up Forward or down
Trip	Engage Release	Rearward or up Forward or down
Grip	Engage Release	Rearward or up Forward or down
Truck stabilizer	Raise Lower	Rearward or up Forward or down
Clamp	Clamp Release	Rearward or up Forward or down

Figure 3-7, ANSI/ITSDF

Sequence of location and direction of motion for lever or hand-type controls

- * For high lift order picker trucks and center control pallet trucks, predominant motion of the operator's hand when actuating the control handle while facing away from the load.
- ** The sense of rotation of the control handle is intended to be in the same direction as the desired motion of the mast or load.

SECTION 4 INSTALLATION AND REMOVAL

4.1 Truck Requirements

CAUTION

Equipment Overload Hazard.

Injury or equipment damage may result if the capacity of the truck and attachment combined are less than the attachment capacity.

Consult truck nameplate for information on capacity of the truck with an attachment installed!

Notice

The dealer and/or the user are responsible for installing any valving required to meet the recommended hydraulic pressures and flow. The required valving can be furnished by the dealer, the truck factory or Long Reach.

Hoses should meet or exceed SAE100 RI Type AT, with maximum working pressure of 3,000 psi for all attachment functions. The lift truck hydraulic system must meet the following specifications:

1. Supply petroleum-based hydraulic oil
2. 7-10 GPM (26.5-37.8 LPM)
3. 2200-2300 PSI (150-160 Bar)
4. At least one auxiliary function (two auxiliary functions required if attachment is equipped with sideshift)
5. For fork-mounted versions (LPF), these additional specifications apply (Figure 4-2):
 - a. Fork thickness: 1.50 - 1.75" (35-45 mm) thick
 - b. Fork length of 48.0 - 42.0" (1220-1066 mm)
 - c. Standard bottom taper on forks
 - d. Minimum fork opening range of 21.8" (550 mm)
 - e. Quick-disconnect fittings are recommended on the supply lines to the attachment
 - f. ITA Class II carriage

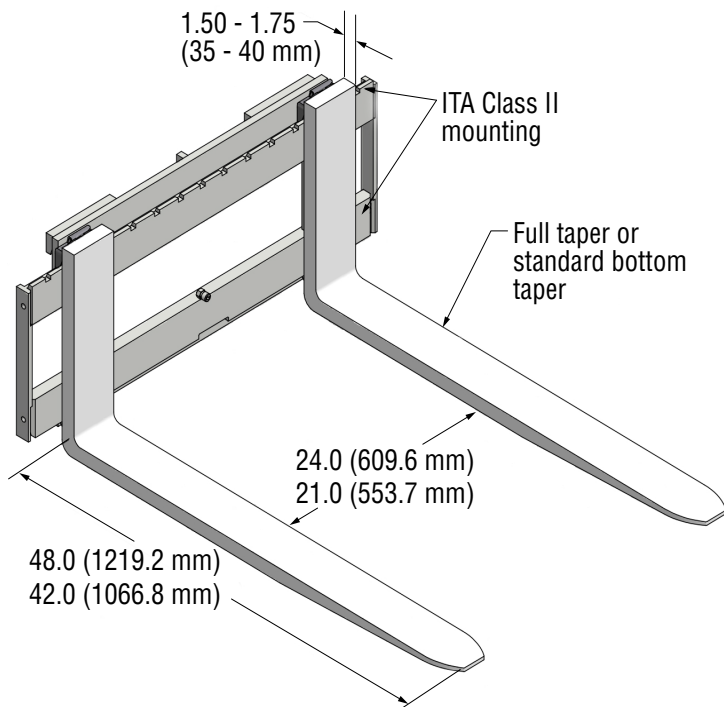

Figure 4-1, Fork Requirements

6. For standard LP and LPBs with hydraulic platens, an over-the-mast electrical cord is necessary to activate the solenoid.

Tools Required:

To work on these attachments you will need a metric set of Allen wrenches, socket drivers and wrenches, 10mm to 14 mm; hex head socket drivers 6 mm to 14 mm; plus the following:

- a. 11/16" end wrench
- b. 3/4" end wrench
- c. 13/16" end wrench

For a fork-mounted attachment (LPF), you will need all the above, plus:

- a. 15/16" socket driver

4.2 Hydraulics

Before connecting the truck hydraulic system to the attachment, the system must be purged through the filtration system. This will eliminate any contamination that might exist in the auxiliary hydraulic system of the truck.

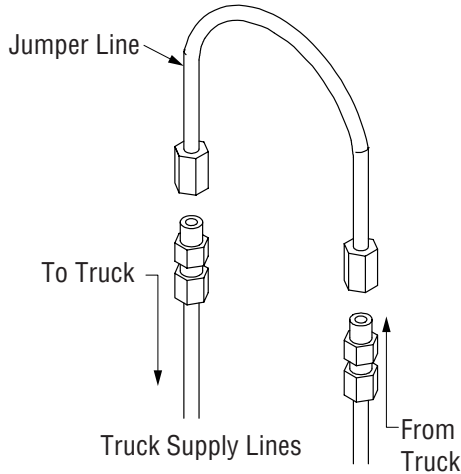

Figure 4-2, Jumper Line

Purge the system by installing a jumper line and operating each hydraulic function (clamp, rotate and side shift, if equipped) in each direction for a minimum of 30 seconds.

4.3 Attachment Handling Safety

Handling push-pull attachments safely means paying close attention to stabilizing the mechanism assembly to prevent unwanted or unexpected movement during any procedure.

WARNING

Crush hazard.

The mechanism assembly will collapse and may cause injury if not stabilized as described below.

Block faceplate rollers securely, and attach a lifting device to the mechanism assembly before starting service procedures.

7. Install wood blocks in the roller tracks as shown in Figure 4-3, to prevent the rollers from moving. The tracks will accept a piece of 2 x 4 (nominal). Use zip ties to secure the blocks in place. Remove blocks and ties before returning the attachment to service.

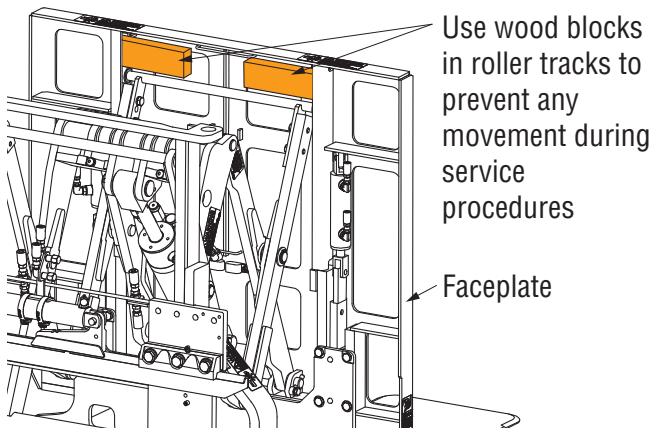

Figure 4-3, Block Rollers

8. Support the mechanism assembly through the upper bar on the inner secondary arm, near its center of gravity. (Figure 4-4)

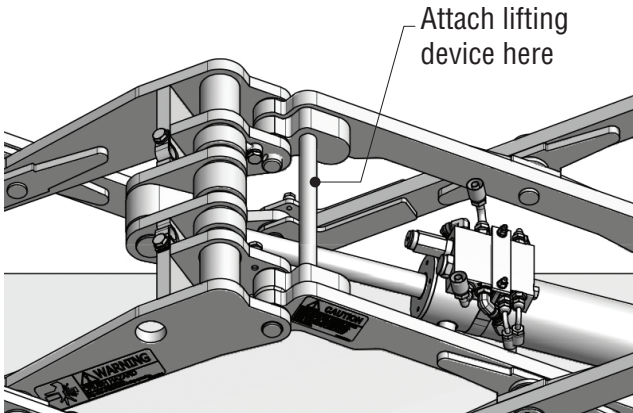

Figure 4-4, Lifting Point

9. Make sure there is NO residual pressure in the hydraulic system when working on the attachment. Cycle levers back and forth to relieve hydraulic pressure after turning off the lift truck. Observe all cautions and warnings in this manual.

 WARNING

Crush Hazard.

Serious injury could result if residual hydraulic pressure causes faceplate to drift outward.

Cycle all hydraulic circuits as described above to relieve all system pressure.

4.4 Attachment Installation, Fork Mounted (LPF Only)

1. Align truck with the attachment. Set fork width to straddle the attachment. Fork position should be set as close to 21.8" (550 mm) between forks as possible, (measured at the fork shank). The forks must be fully underneath the platens and the fork lock pin engaged in a carriage notch.
2. Angle the fork tips slightly towards the floor.
3. Move forward slowly until truck comes into contact with rear of unit. Continue moving forward until fork surface is flush with the attachment, then tilt back all the way.
4. Raise the attachment to waist height or until lower hook and upper stop are accessible. Turn off lift truck.
5. Depress button on the detent pin and pull the pin out. Reach under attachment and hand-raise the lower hook to align the lower hook holes and the attachment holes, lifting directly under the pin. Insert the detent pin in the hole corresponding to the lift truck's fork thickness, see decal. Repeat for opposite side. (Figure 4-5)

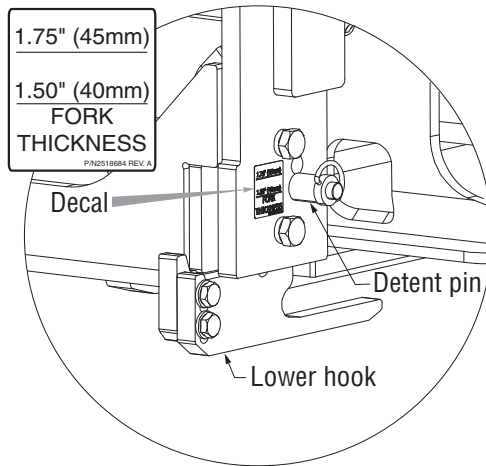

Figure 4-5, Fork Mounted Attachment

6. Measure gap between the top of the adjustable lower hook and the lower carriage bar (Figure 4-6). Gap should not exceed 3/16" (4.7 mm). Adjust the gap by loosening the bolts holding the adjustable lower hook to the rear of the lower hook. Tighten the bolts to the torque stated on page 18. Repeat for opposite side.

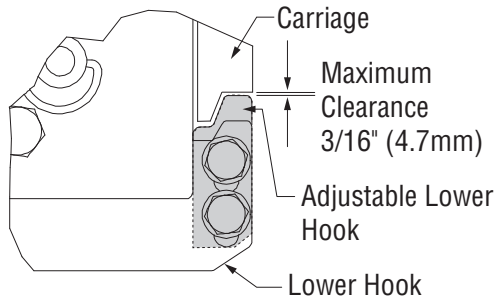

Figure 4-6, Lower Hook Clearance

7. Loosen the bolts holding the adjustable upper stop and position the stop to provide clearance to within 1/8" (3.2 mm) of the top carriage bar. Tighten the bolts to the torque stated on page 18. (Figure 4-7)

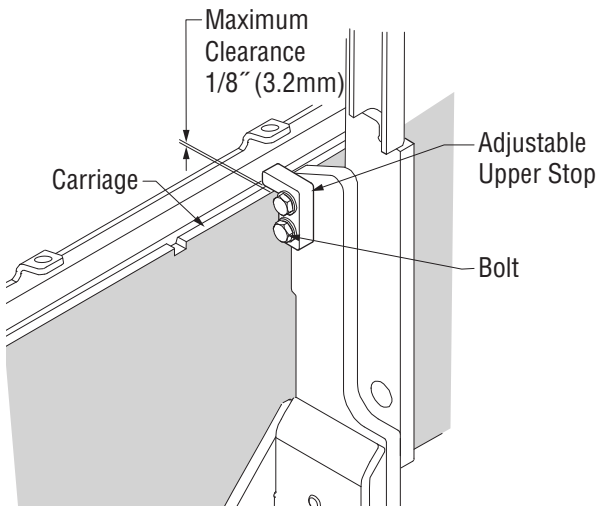

Figure 4-7, Fork Mounted Upper Stop

8. If quick hooks are used instead of bolt-on hooks, make sure the truck carriage allows the slide plate (see Figure 4-8) to be raised high enough to click into place. Slide plate must click into place. Contact factory (800-285-7000) if the slide plate does not click into place.
9. Connect the hydraulic supply hoses from the lift truck carriage to the attachment. Ensure all hydraulic supply hoses are secured to carriage. Refer to Section 4.1.
10. Inspect installation to ensure hoses are not kinked or pinched between the truck carriage and attachment.
11. Operate all functions slowly and continuously for several minutes to determine that all hydraulic connections are secure, with no leaks or interference.

12. Completely retract faceplate and check lower hook clearance (Figure 4-6). Reset as necessary to meet stated clearance.

4.5 Attachment Removal, Fork Mounted (LFP Only)

Refer to Section 4.3 Attachment Handling Safety for safe handling requirements.

1. Extend the faceplate fully.
2. Turn off the lift truck and relieve pressure from the auxiliary lines by cycling all levers back and forth several times.



WARNING

Crush Hazard.

Serious injury could result if residual hydraulic pressure causes faceplate to drift outward.

Cycle all hydraulic circuits as described above to relieve all system pressure.

3. Disconnect hydraulic hoses and cap hose ends with metal plugs and caps to prevent cylinder travel during handling. Tag for reassembly.
4. Reach under attachment to support the hook. Remove detent pin and lower the hook. Replace detent pin in top hole. Repeat for opposite side.
5. Lower carriage and attachment to floor. Back away from the attachment. Platen tips will rest on floor.

4.6 Attachment Installation, Dedicated (LP)

Refer to Section 4.3 Attachment Handling Safety for safe handling requirements.

6. Remove the lower bolt-on hooks and, if applicable, make a note of any factory installed shims. If quick change hooks are used, simply depress the button on the back of the hooks, allowing the slide plate to drop, Figure 4-8.

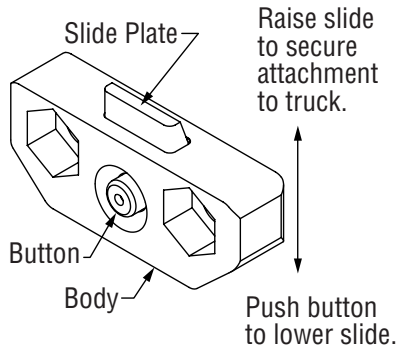

Figure 4-8, Quick Change Hook

7. Center the truck behind the attachment and drive toward the attachment with the mast tilted forward approximately 4°.
8. Line up the locking lug (if applicable) with the appropriate notch on the truck's carriage.
9. Make sure the wear pads (sideshifting units only) are in place and making contact with lower carriage bar.

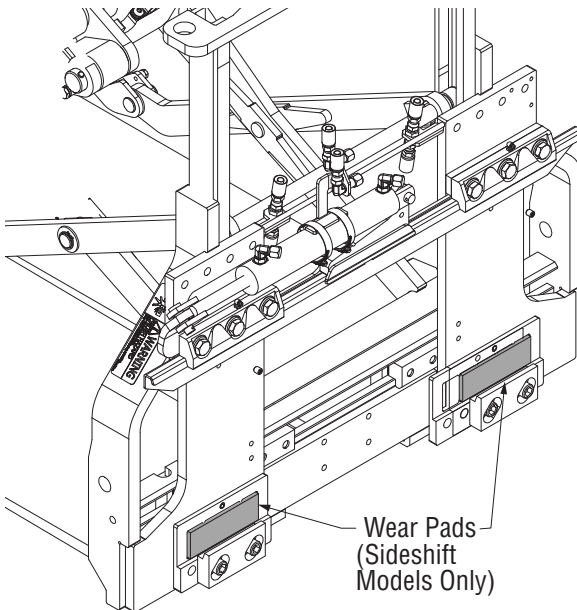

Figure 4-9, Wear Pad Locations

10. Slowly raise the truck carriage completely to engage the top hooks with the truck carriage. Tilt carriage back until the unit is against the carriage bottom fork bar (0°).

11. Install the bolt-on lower hooks. Prime and apply Loctite 242 (Blue) to M16 X 2 capscrews before installation. Adjust the lower hooks for a maximum clearance of .078" (2 mm). See Figure 5-2. Torque bolts, and re-torque after the first 5-10 hours of use.

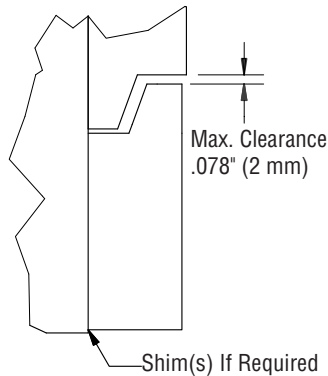

Figure 4-10, Lower Hook Clearance

12. If quick hooks are used instead of bolt-on hooks, make sure the truck carriage allows the slide plate (see Figure 4-6) to be raised high enough to click into place. Slide plate must click into place. Contact factory (800-285-7000) if the slide plate does not click into place.

! WARNING

Equipment failure hazard.

The attachment could fall off the truck if the quick hook is not properly installed.

Slide plate must click into place. If the slide plate does not click into place because the truck carriage prevents the slide plate from being raised up high enough, install shims between the attachment and the body of the quick hooks.

13. Apply grease to bronze top hooks through fittings and spread on entire slide area of mid plate.
14. Check all fittings, connections and bolts for any interference.
15. Connect the truck hydraulic supply to the unit.

4.7 Attachment Removal, Dedicated (LP)

Refer to Section 4.3 Attachment Handling Safety for safe handling requirements.

1. Extend faceplate fully.
2. Turn off the lift truck and relieve pressure from the auxiliary lines by cycling all levers back and forth several times.
3. Disconnect hydraulic hoses and cap hose ends with metal plugs and caps to prevent cylinder travel during handling.
4. Slightly raise the truck carriage to remove the bottom mounting hooks

If the attachment is equipped with quick change hooks (button-type), press the slide plate release button and drop the slide plate down (Figure 4-6).

If the attachment is equipped with quick change hooks (pin-type), remove the retaining pin and the quick change hook.

SECTION 5 MAINTENANCE

5.1 Maintenance Schedule Daily:

1. Visually inspect all hoses, fittings, cylinders, and valves for signs of hydraulic leaks.
2. Inspect hoses for wear/pinching and replace as required.
3. Inspect platens for nicks, dents, rough spots, and repair as required.
4. Visually inspect lower hook installation and check unit for external damage or cracks.

40 Hour Maintenance:

1. Complete the above daily checks.
2. Inspect retaining pins and replace as required.
3. Tighten mechanism pivot retaining pin bolts.
4. Lube bronze top hooks if needed.
5. Lube mechanism if desired. (Use light oil.)
6. Lube platen cylinder grease zerks (if so equipped).
7. Check lower hook clearance ($3/16'' = 5 \text{ mm}$ maximum) and adjust as required.
8. Tighten and torque all bolts (see Section 5.2), especially:
 - a. Top hooks
 - b. Lower hooks
 - c. Platen hooks
 - d. Gripper jaw capscrews
9. Inspect any forks that contact the ground. The fork blade and shank must be thoroughly checked for wear, especially near the heel. Reference Form 45-038 Fork Wear Inspection for instructions.

500 Hour Maintenance

1. Perform 40 hour inspection.
2. Check gripper pad for tears or excessive wear and replace as required.
3. Inspect bushings for excessive clearance ($1/32'' = 1 \text{ mm}$ maximum) at all pivots and replace as required.

Recommended Grease:

Mobile XHP222 Special, or similar quality EP-2 with Lithium Complex Base.

Recommended Dry Film Graphite Coating:

1. SLIP Plate #3, or similar, to lubricate platens as needed.

5.2 Torque Specifications

The following torque values are to be used on all fasteners unless otherwise specified.

Lubricated refers to fasteners in the “As Received” condition, which is normally a light preservative oil coating on unplated fasteners and no oil coating on plated fasteners. No special steps are taken to add further lubrication prior to assembly. Dry refers to parts that have been degreased, both mating parts.

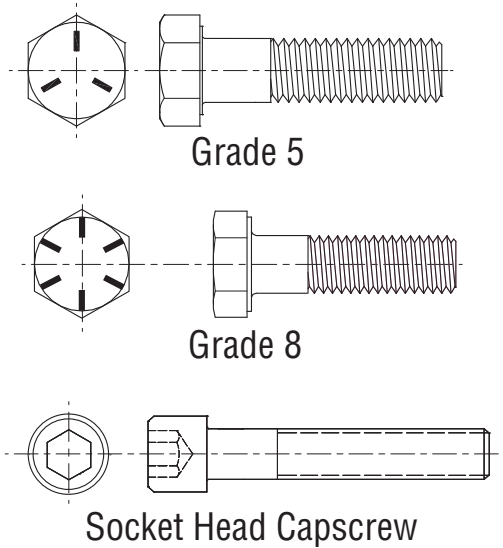

Figure 5-1, Bolt Identification

GRADE 8 COARSE THREAD		GRADE 5 COARSE THREAD		SOCKET HEAD COARSE THREAD	
Bolt Size	Lubricated Torque	Bolt Size	Lubricated Torque	Capscrew Size	Lubricated Torque
1/4"	11 ft-lbs	1/4"	7.5 ft-lbs	1/4"	12.5 ft-lbs
5/16"	23	5/16"	16	5/16"	26
3/8"	40	3/8"	28	3/8"	46
7/16"	63	7/16"	45	7/16"	74
1/2"	96	1/2"	68	1/2"	115
9/16"	140	9/16"	98	9/16"	160
5/8"	195	5/8"	140	5/8"	215
3/4"	340	3/4"	240	3/4"	385
7/8"	550	7/8"	390	7/8"	615
1"	820	1"	580	1"	920
1-1/8"	1,160	1-1/8"	715	1-1/8"	1,305
1-1/4"	1,640	1-1/4"	1,010	1-1/4"	1,840
1-3/8"	2,150	1-3/8"	1,330	1-3/8"	2,415
1-1/2"	2,850	1-1/2"	1,760	1-1/2"	3,205

Figure 5-2, Torque Specification

SECTION 6 SERVICE PROCEDURES

6.1 Attachment Handling Safety

Handling push-pull attachments safely means paying close attention to stabilizing the mechanism assembly to prevent unwanted or unexpected movement during any procedure.

WARNING

Crush hazard.

The mechanism assembly will collapse and may cause injury if not stabilized as described below.

Block faceplate rollers and securely attach a lifting device to the mechanism assembly before starting service procedures.

1. Install wood blocks in the roller tracks as shown in Figure 6-1, to prevent the rollers from moving. The tracks will accept a piece of 2 x 4 (nominal). Use zip ties to secure the blocks in place. Remove blocks and ties before returning the attachment to service.

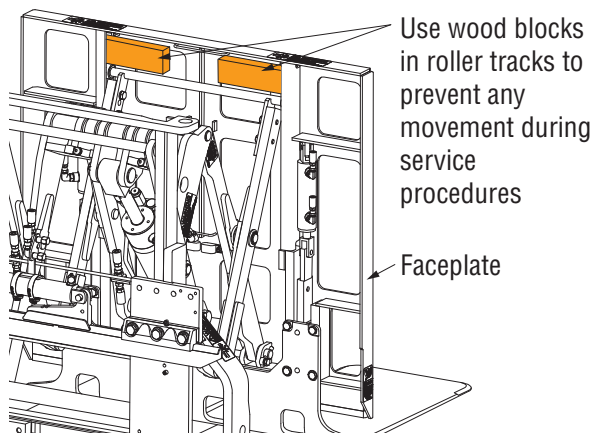

Figure 6-1, Block Rollers

2. Support the mechanism assembly through the upper bar on the inner secondary arm, near its center of gravity. Figure 6-2

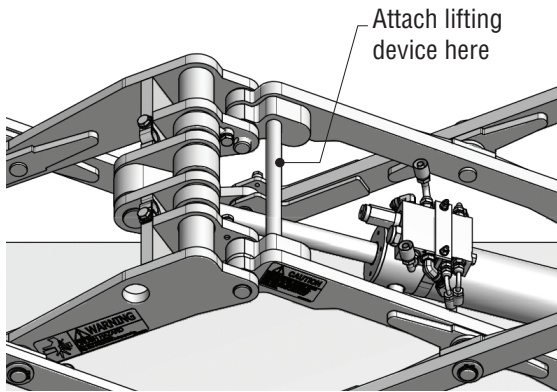

Figure 6-2, Lifting Point

3. Make sure there is NO residual pressure in the hydraulic system when working on the attachment. Cycle levers back and forth to relieve hydraulic pressure after turning off the lift truck. Observe all cautions and warnings in this manual.

! WARNING

Crush Hazard.

Serious injury could result if residual hydraulic pressure causes faceplate to drift outward.

Cycle all hydraulic circuits as described above to relieve all system pressure.

! WARNING

Crush hazard.

If the cylinder is removed from the assembly prior to lifting, the mechanism will collapse and may cause injury.

Securely attach a lifting device to the mechanism assembly before removing the cylinder.

6.2 General

Not all procedures require that the attachment be removed from the truck. Review each procedure before beginning. Make sure any lifting equipment used is rated for the load being lifted.

6.3 Pivot Pin Installation and Removal

Refer to Section 6.1 Attachment Handling Safety for safe handling requirements.

1. Before removing the pin, remove the bolt and retaining pin and insert a brass drift punch into the retaining pin hole. Check to see if the pin will rotate by hand. If the pin is difficult to hand turn, lower or raise the lifting device and then check the pin again.
2. To prevent damage to the bushing, the brass drift should have a minimum diameter of 0.5" (12.7 mm) at the bore end.

CAUTION

Bushing damage.

The bushing could be damaged if the hole for the pivot pin retainer is allowed to enter the bushing.

Make sure the pivot pin does not move inward.

3. Each pivot pin is retained with an eyebolt held in place with a capscrew and lockwasher. Carefully remove pins without passing the hole through the bushing. This is accomplished by removing and installing the pin as shown in Figure 6-3.

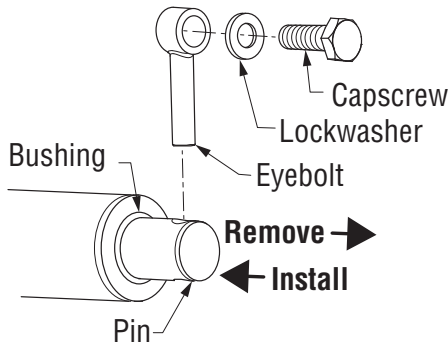

Figure 6-3, Pivot Pin Installation

4. To reinstall, follow the removal steps in reverse.

6.4 Cylinder Removal

Refer to Section 6.1 Attachment Handling Safety for safe handling requirements.

1. Extend mechanism fully.
2. The lifting device supporting the mechanism may need to be raised or lowered to access the cylinder pivot pins.

3. Before disconnecting any hydraulic connections, turn off truck power and activate the truck's hydraulic functions in both directions to bleed off the hydraulic pressure.

WARNING

Crush Hazard.

Serious injury could result if residual hydraulic pressure causes faceplate to drift outward.

Cycle the hydraulic circuit as described above to relieve all system pressure.

4. Disconnect and cap supply lines to the manifold on the cylinder. Disconnect and cap gripper hoses attaching to the manifold. Tag hoses for reassembly.
5. Remove eyebolts retaining cylinder pivot pins.
6. Tap out cylinder pivot pins from the side opposite the eyebolts. The end of the pivot pin with the eyebolt hole should never pass through the cylinder end. Support the cylinder (weight: 30 lbs/13.6 kg) to avoid possible injury when the pins are removed. (Figure 6-4)

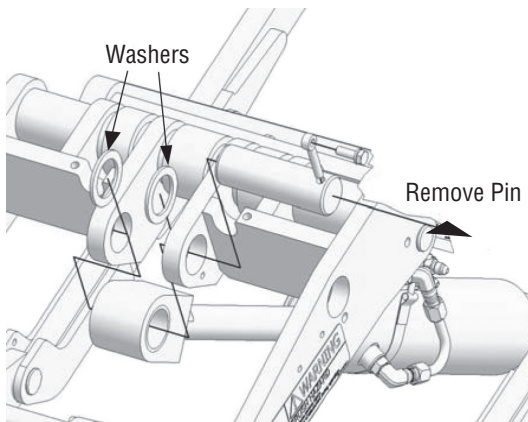

Figure 6-4, Cylinder Removal

7. Set aside cylinder pivot pins, washers, and eyebolts.

6.5 Cylinder Installation

Refer to Section 6.1 Attachment Handling Safety for safe handling requirements.

1. Extend the cylinder fully.
2. Install the cylinder pivot pins with the washers. Tap in gently from the side with the retaining pin hole to avoid damage to the bushing. The lifting device supporting the mechanism may need to be raised or lower to exactly match the hole locations.

3. Reinstall the retaining eyebolts on both cylinder pins.
4. Reconnect the supply lines and the gripper hoses to the manifold.
5. Reconnect the hydraulics to the attachment.

6.6 Gripper Pad Removal

Refer to Section 6.1 Attachment Handling Safety for safe handling requirements.

1. Extend the mechanism fully.
2. Turn off the lift truck and bleed the pressure from the auxiliary lines by cycling the lever back and forth several times.



WARNING

Crush Hazard.

Serious injury could result if residual hydraulic pressure causes gripper bar to drift down.

Cycle the hydraulic circuit as described above to relieve all system pressure.

3. Disconnect and cap supply lines to the manifold on the cylinder. Disconnect and cap gripper hoses attaching to the manifold. Tag hoses for reassembly.
4. Remove push pull jaw bolts (quantity: 8) and push pull jaw. Make note of factory-installed shims.
5. Disconnect gripper bar. Remove the cotter pins and the cylinder pins to remove the gripper bar.
6. Remove the bolts attaching the gripper pad (quantity:9) to the gripper bar.
7. When the gripper assembly is disassembled to this point, check the bushings for wear. Replace as needed. (Figure 6-5)

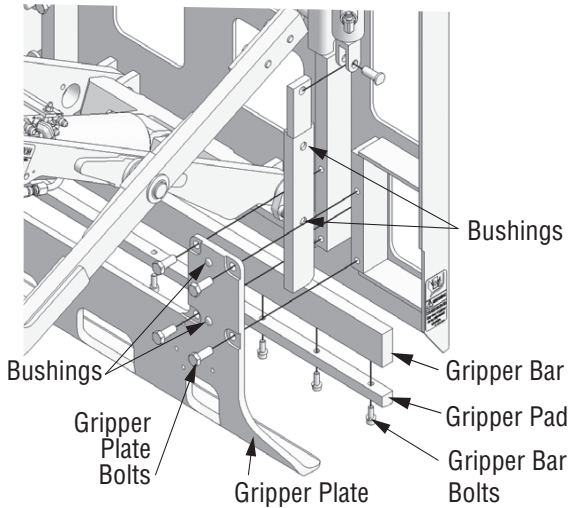

Figure 6-5, Gripper Pad Removal

6.7 Gripper Pad Installation

1. Reinstall the gripper bar bolts and torque to 28 ft-lbs (38 N-m).
2. Make sure the gripper bar is oriented correctly, with the flush (flat) side facing the faceplate. Connect the gripper bar to the gripper cylinders and insert the cotter pins into each of the cylinder pins.
3. Secure the push pull jaw with the push pull jaw bolts. Torque the push pull jaw bolts to 84 ft-lbs (114 N-m).
4. Reconnect the hydraulics to the attachment.

6.8 Faceplate Angle Adjustment

1. Extend mechanism fully and turn off lift truck.
2. Support the faceplate so that it does not tip.
3. Remove the bolts securing the front stabilizer to the outer secondary arm.
4. Use the stabilizer arm holes to align the faceplate at the desired angle. Insert bolts into the threaded holes and tighten securely. (Figure 6-6)
5. Cycle the unloaded attachment to verify that there is no catching or binding.

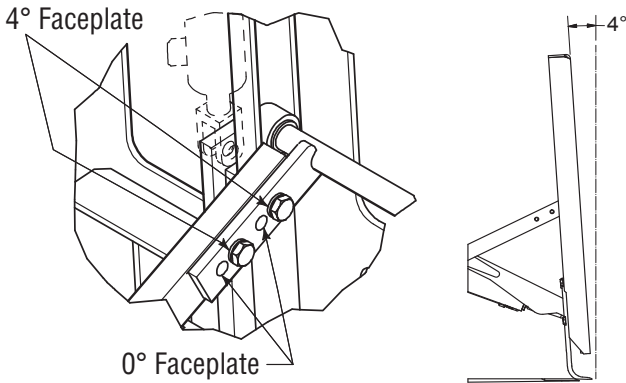

Figure 6-6, Stabilizer Arm Alignment

6.9 Platen Removal

1. Fully extend the faceplate.
2. Lower the attachment until platens rest evenly on the floor.
3. Remove the platen lock bar, upper hook retaining bolts, upper hooks, and shims. Zip tie upper hooks and shims together to maintain proper orientation.
4. Raise the attachment up and off of the lower hook and back away from the platens.

6.10 Platen Installation

1. Position platens side by side on the floor using the platen lock bar (Figure 6-11) as a template. Space the platens at the desired width. If necessary, remove graphite coating (such as Slip Plate No. 3) from platens with solvent or paint remover. Refer to product label and the manufacturer's instructions.
2. Align the platen pair to the center of the attachment. Raise the attachment until it clears lower platen hooks. Drive truck forward until carriage contacts the platen.
3. Lower the attachment slowly into the platen's lower hooks.

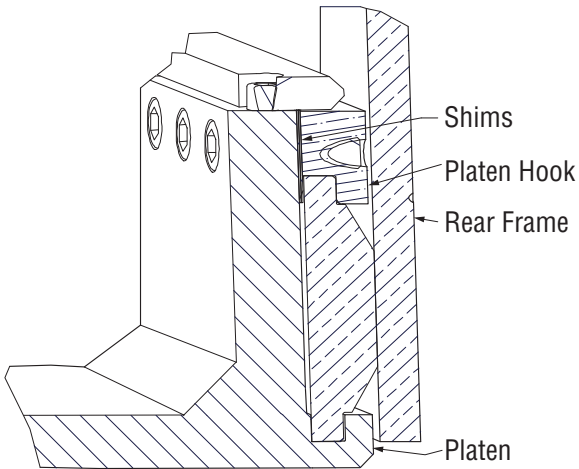

Figure 6-7, Platen Shims

4. Install the upper hooks and shims. (Figure 6-7) Leave the hook retaining bolts loose (Figure 6-8).

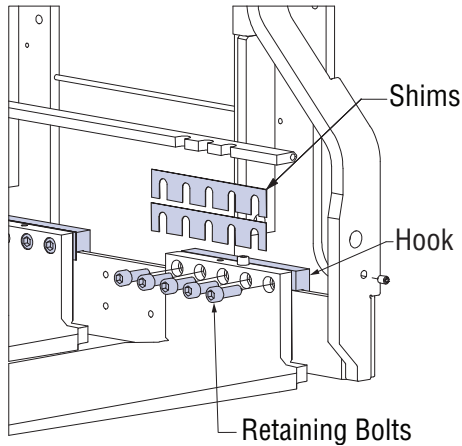

Figure 6-8, Hook installation

5. Raise the attachment approximately 1/2" from the floor. Retract the faceplate to 4" from the platen tips. (Figure 6-9)

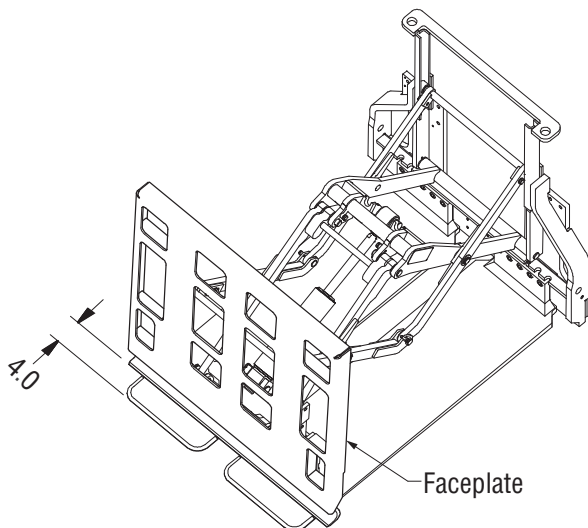
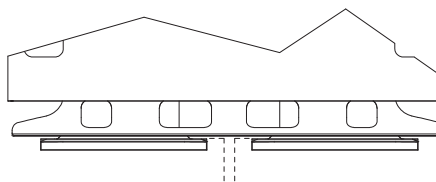

Figure 6-9, Platen Position

6. Adjust the platens by adding or removing shims until the platen tips are within $1/16''$ of the push pull jaw and both tips are no more than $1/4''$ height difference. (Figure 6-10)



Platen tips must be
even or within 0.25"

Figure 6-10, Platen Tip Alignment

Notice

Add shims to lower the tip. Remove shims to raise the tip. The thinnest shim will move the tip of the platen about .188" (3/16"). The thickest shim will move the platen tip .375" (3/8").

7. Install the platen lock bar and position the platens to line up with their corresponding lock notches on the bar. Install the M12 socket head bolt into the top of the platen heel. (Figure 6-11)

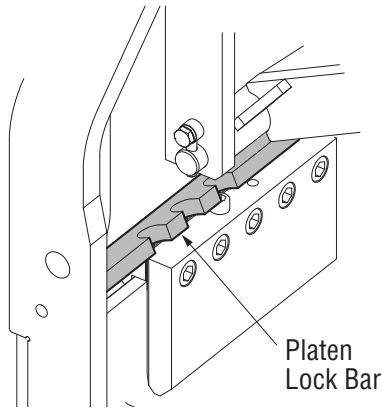

Figure 6-11, Platen Repositioning

8. Use Loctite 242 and torque the M16 platen hook retaining bolts to 166 ft-lbs (225 N-m).
9. Operate the attachment to ensure that the push pull jaw does not interfere with or force platens downward.

6.11 Platen Repositioning

1. Extend the mechanism, and turn off the lift truck.
2. Rotate the platen lock bar as shown to clear the bolt on the platen heel.
3. Place a lifting device around the platen at the specified distance from the platen heel. See chart in Figure 6-12.

Length (in.)	Width (in.)	Weight (lbs/kg)	Strap distance (in.) from heel	Part No.
42	18	187.5/85	14.4	2517982
48	8.50	140/63.5	14	2518924
48	14	164.5/74.6	15.7	2526162
48	15	170/77	16	2508346
48	15	187.5/85	16	2508293
48	18	195/88	16.7	2517661
48	18	215/97.5	17.7	2517660
64	18	230/104	23	2520464

Figure 6-12, Platen Chart

4. Slide the platen in the desired direction, aligning its final position with a cutout in the platen lock bar and a threaded hole on the top of the heel.

- a. If the platen does not slide, add more shims.
 - b. Upon re-tightening, the bolts MUST have medium strength thread locker applied and be torqued to 166 ft-lbs (225 N-m).
5. Remove the lifting device.

6.12 Platen Disassembly

1. Fully extend the faceplate. Retract the platen cylinders.
2. Turn off the lift truck and bleed the pressure from the auxiliary lines by cycling the levers back and forth several times.
3. Disconnect the hydraulic hoses that attach to the cylinder, and then disconnect the cylinder fittings (Figure 6-13). Cap and tag for reassembly.

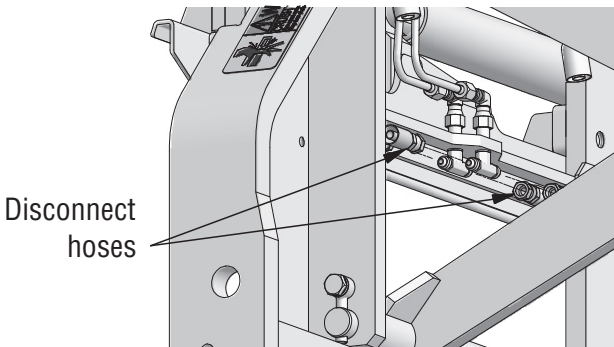

Figure 6-13, Disconnect Hoses

4. Remove the cotter pin and clevis pin holding each end of the cylinder to the platens. (Figure 6-14)

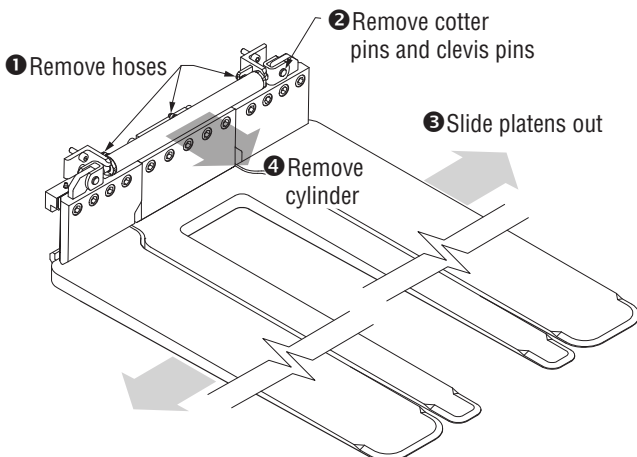

Figure 6-14, Remove Cylinder

5. With pins removed, slide both of the platens out to free the cylinder ends.
6. Carefully remove the cylinder from the platen by pulling directly out the front of the unit. Do not scratch the cylinder rod.
7. If the fittings need to be removed, mark their rotation relative to the body. The fittings must be aligned so that they do not contact the rear frame when the platens are positioned out.

6.13 Platen Reinstallation

1. To reinstall the platens, follow the disassembly procedures in reverse.
2. Once the cylinder is installed, reconnect the hydraulic hoses as they were, making sure the hose ends are pointing in their original directions.

6.14 Platen Lubrication

1. Recoat the platens with a dry film graphite coating as needed when the platens start to show wear, or if excessive friction is noticed.



Coating damage.

Using a petroleum-based lubricant over the dry film graphite coating will degrade the dry film and cause friction on the platens.

Use recommended dry film graphite coating to recoat the platens.

2. Maintenance intervals depend on surface wear. Reapply anti-friction coating SLIP Plate #3, following manufacturer's instructions.

6.15 Mechanism Disassembly

1. Remove the faceplate assembly from the mechanism.
 - a. Extend the mechanism $\frac{3}{4}$ of the way to access the eyebolts on the faceplate. Remove the retaining pins but not the secondary mechanism pivot pins.
 - b. Extend the mechanism fully. Shut the truck off. Disconnect, cap and tag hydraulic connections.
 - c. Support the faceplate with an appropriate lifting device. The standard (48" x 48") faceplate assembly weighs approximately 220 lbs (100 kg).
 - d. Disconnect and cap the gripper lines at the manifold on the main cylinder. Tag for reassembly.



DANGER

Injection Hazard.

Infection and gangrene will result when hydraulic oil penetrates the skin. See a doctor immediately to prevent loss of limb or death.

Before cycling the hydraulics, verify that all of the capped ports are tightened to prevent leakage or sprays.

- e Remove the eyebolts and the secondary mechanism pivot pins on the faceplate.
 - f Remove the four bolts that secure the front stabilizer to the outer secondary arms. This will disconnect the faceplate assembly from the mechanism.
2. Remove the mechanism from the rear frame.
- a During the mechanism removal and disassembly, note the position and quantity of all spacers and washers for reassembly.
 - b With the gripper ports capped, extend the mechanism fully, then turn off the lift truck and cycle the auxiliary function several times to bleed the pressure from the lines.
 - c Disconnect the lines supplying the manifold at the manifold. Cap all ports and hoses. Remove the hoses from the retaining clips on the inner primary arm as well.
 - d Support the mechanism through the uppermost bar on the inner secondary arm as shown (Figure 6-15), with an appropriate lifting device. A standard mechanism assembly weighs approximately 275 lbs (125 kg).

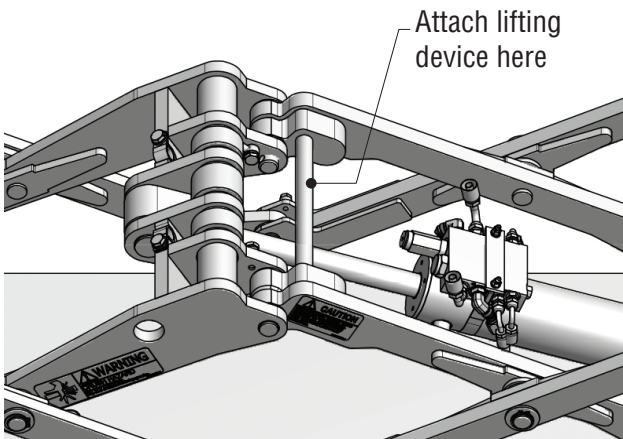

Figure 6-15, Lifting Point



WARNING

Crush Hazard.

Death or serious injury could result if inner mechanism arms are not supported during mechanism disassembly.

Support the inner arms when the main cylinder is removed.

- e. Remove the eyebolt on the primary mechanism pivot pin and tap out the primary mechanism pivot pin. Use a rod that has a radius of at least 0.25" (6.2 mm) on the contact end to avoid damage to the bushings. After the pin is out, carefully remove the rod that was used to extract the pin, use care as the mechanism may shift once the extraction rod is removed.
 - f. Lift the rear stabilizer on the mechanism out of the rear frame to remove the mechanism.
3. Disassemble the mechanism. (Figure 6-16)
- a. Remove the four snap rings retaining the outer primary and secondary arms, and remove the two bolts holding the rear stabilizer in place. Take off the rollers and the washers on the rear stabilizer as well. Remove the outer arms together. They should slide off without the use of a hammer; if not, the bushings may need to be replaced.
 - b. Support the mechanism before removing the cylinder. Use the same lifting point used to remove the mechanism from the rear frame. (Figure 6-15)

Remove the main cylinder. The inner arms of the mechanism will collapse unless supported.

- c. Remove the retaining pins on the top mechanism pivot pins and tap out the pins. Use a .5" (12.4 mm) diameter rod on the contact end to avoid damage to the bushings in the inner secondary arm. Tap the pins into the center of the mechanism. Do not pass the retaining pin hole across the bushings in the primary arm. (Figure 6-3)

6.16 Bushing Replacement

1. Bushings are all fiber-type. Where bushings are installed in a blind hole, cut the bushing along its axis using a hacksaw blade or a die grinder. Use caution to avoid cutting into the walls of the bore.
2. If possible, tap the bushing through the bore. Tapping the bushing to rotate it in the bore will also make the extraction easier. Use caution to avoid damage to the bushing bore.
3. If the bore that holds the bushing is cut or dented, use a fine grit sandpaper to remove any burrs before installing a new bushing.
4. To install a new bushing use installation tool, part numbers X-202145 and X-202146, to support the bushing during installation.
5. DO NOT use a hammer when installing a new bushing. Use an arbor press, capable of 7 tons (6.3 metric tons). Due to bore size, using a hammer could install the bushing at an angle and cause damage to the bushing and reduce its usable life.
6. When installing a .75" ID bushing, the press must be monitored so that the bushing is not pushed through the bore. Due to installation tool design and the size of the bushing, it can be pushed fully through the bore.

6.17 Mechanism Reassembly

1. To assemble the mechanism, follow disassembly steps in reverse.

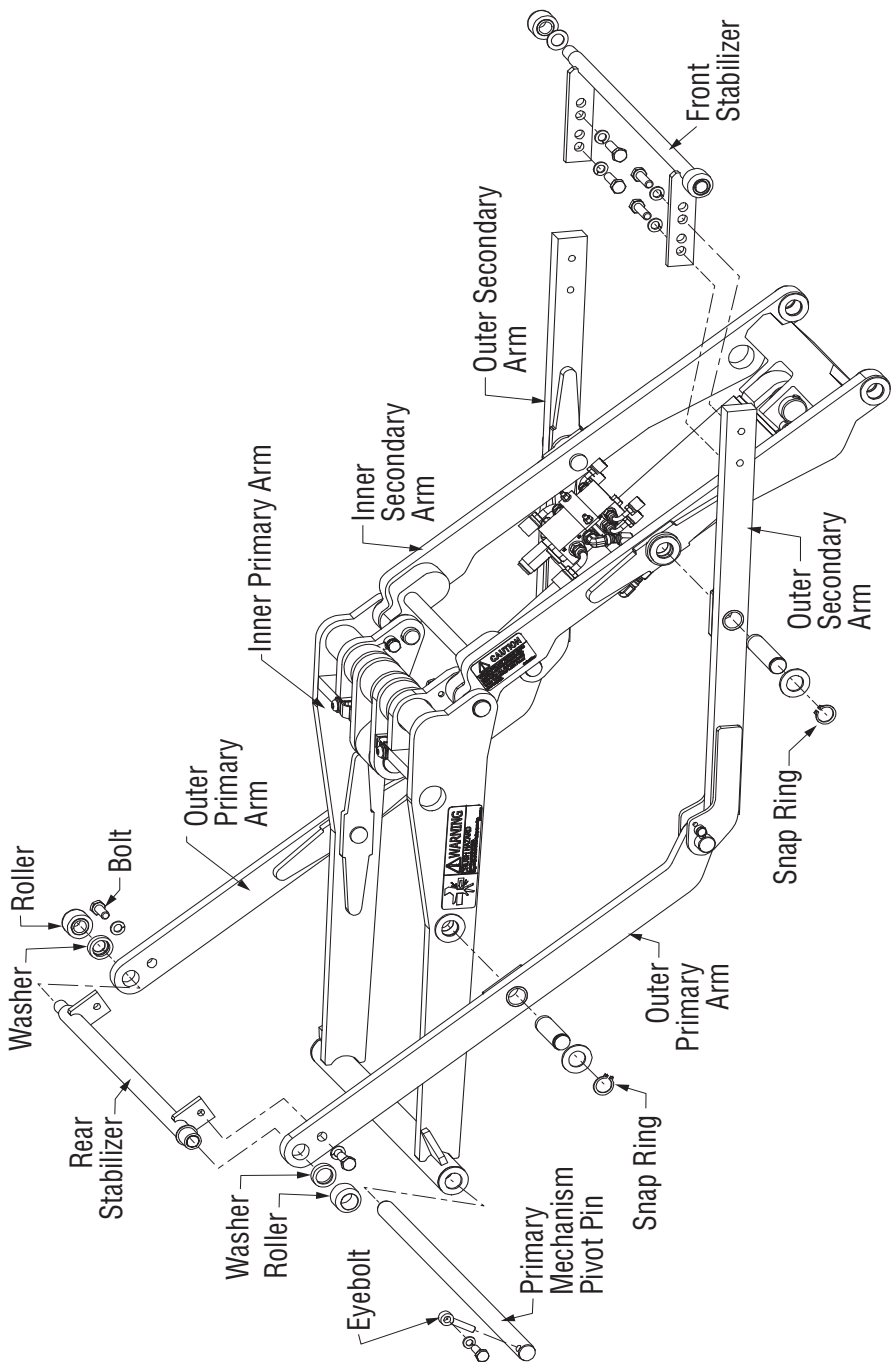

Figure 6-16, Mechanism Disassembly

THIS PAGE WAS INTENTIONALLY LEFT BLANK

Find the latest version of your
complete parts documentation
in the **Manuals and**
Publications tab at
www.alliedsystems.com.

www.alliedsystems.com
21433 Oregon Street, Sherwood, OR 97140, USA
Phone: 800.285.7000 Fax: 800.231.3273