



# Installation, Maintenance and Service Manual KHA

Beer Keg Handler

THIS PAGE WAS INTENTIONALLY LEFT BLANK

# TABLE OF CONTENTS

<b>SECTION 1 NAMEPLATE LOCATION</b> .....	<b>4</b>	<b>SECTION 4 INSTALLATION PROCEDURE</b> .....	<b>17</b>
<b>SECTION 2 MODEL NUMBER DESCRIPTION</b> .....	<b>5</b>	4.1 Truck Requirements .....	17
<b>SECTION 3 SAFETY SUMMARY</b> .....	<b>6</b>	4.2 Attachment Installation.....	18
3.1 Safety Information.....	6	4.2.1 Bolt-On Hooks .....	18
3.2 Production Modifications.....	6	4.2.2 Quick Hooks .....	19
3.3 Safety Regulations.....	6	4.3 Installations with Bolt-On Hooks	20
3.4 Safety Symbols .....	6	4.4 Installations with Quick Hooks ...	21
3.5 Labeling .....	7	<b>SECTION 5 SERVICE PROCEDURE</b> ...	<b>23</b>
3.6 Training .....	7	5.1 Attachment Removal.....	23
3.7 Personnel Safety.....	8	<b>SECTION 6 MAINTENANCE</b> .....	<b>25</b>
3.8 Pre-start Checks .....	9	6.1 Schedule.....	25
3.9 Operation Warnings .....	9	6.2 Torque Specifications .....	25
3.10 Hydraulic Hazards .....	10		
3.11 Electrical Hazards .....	10		
3.12 Maintenance Warnings .....	10		
3.13 Load Handling.....	12		
3.14 Load Positioning.....	13		
3.15 Operator's Controls .....	13		
3.16 Industry Standards.....	14		
3.17 Clamp Open Control .....	15		

# SECTION 1 NAMEPLATE LOCATION

## NOTICE

When you receive your attachment, locate the Long Reach nameplate (upper left corner on the body). Record the information from the nameplate, along with the date received, at the bottom of this page. If the nameplate is missing, look for the serial number stamped directly into the metal at the nameplate location and consult the factory for details.

Date received:

-   -

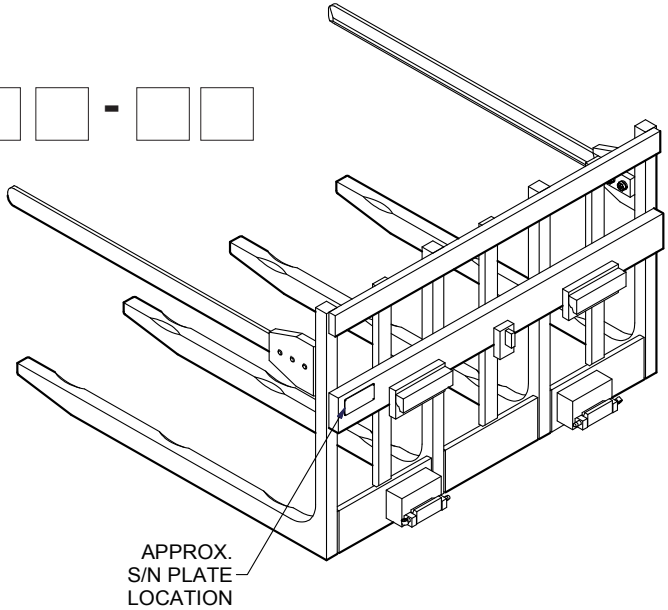

<b>LONG REACH</b> A Division of Allied Systems Company		21433 SW Oregon Street Sherwood OR 97140 USA www.alliedsystems.com		2500005 rF	
MODEL NO.:	<input style="width: 100%;" type="text"/>			SERIAL NO.:	<input style="width: 100%;" type="text"/>
CAPACITY AT LOAD CENTER:	<input style="width: 50px;" type="text"/> KG @ <input style="width: 50px;" type="text"/> MM	MASS:	<input style="width: 50px;" type="text"/> KG	AET:	<input style="width: 50px;" type="text"/> MM
	<input style="width: 50px;" type="text"/> (LBS) @ <input style="width: 50px;" type="text"/> (IN)		<input style="width: 50px;" type="text"/> (LBS)		<input style="width: 50px;" type="text"/> (IN)
MAXIMUM HYDRAULIC PRESSURE:	<input style="width: 50px;" type="text"/> BAR	FLOW:	<input style="width: 50px;" type="text"/> L/mIn	HCG:	<input style="width: 50px;" type="text"/> MM
	<input style="width: 50px;" type="text"/> (PSI)		<input style="width: 50px;" type="text"/> (GPM)	VCG:	<input style="width: 50px;" type="text"/> MM
			<input style="width: 50px;" type="text"/> (IN)	LCG:	<input style="width: 50px;" type="text"/> (IN)
DATE:	<input style="width: 100%;" type="text"/>			SEE TRUCK NAMEPLATE FOR COMBINED TRUCK & ATTACHMENT CAPACITY	

## SECTION 2 MODEL NUMBER DESCRIPTION

Each clamp is identified by a model number and a serial number located on the name plate attached to the unit prior to shipment. Long Reach's model numbers are designed to describe how an attachment is equipped. The guide below illustrates the information that is represented in the model number. Always include model and serial number when ordering parts or requesting service information.

### KHA Series Model Number:

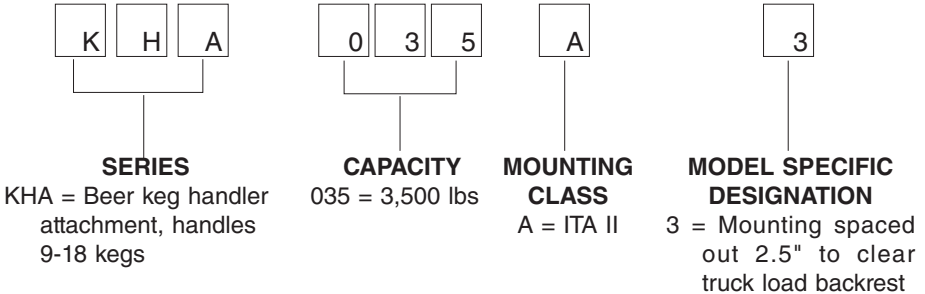

## SECTION 3 SAFETY SUMMARY

### 3.1 Safety Information

#### Safety is Everyone's Responsibility

Whether you are new on the job or a seasoned veteran, these safety tips may prevent injury to you, to others, or to the materials you are handling. Always be alert, watch out for others, and follow these suggestions:

**Attachments handle material, not people.**

**Safety starts with common sense, good judgement, properly maintained equipment, careful operation, and properly trained operators.**

The safety instructions and warnings, as documented in this manual and shipped with the machine, provide the most reliable procedures for the safe operation and maintenance of your Long Reach attachment. It's your responsibility to see that they are carried out.

### 3.2 Product Modifications

Any alterations to the product, that have not been approved by Allied Systems Company or use of any non-OEM replacement parts will void the warranty, and may introduce serious safety hazards. Any non-OEM parts used, or any alterations made are done so at your own risk to personnel safety. This includes the addition of accessories and attachments not manufactured by Allied Systems Company.

### 3.3 Safety Regulations

Know your company's safety rules. Some companies have site-specific directions and procedures. The methods outlined in your operator's manual provide a basis for safe operation of the machine. Because of special conditions, your company's material handling procedures may be somewhat different from those shown in this manual.

### 3.4 Safety Symbols

The following terms define the various precautions and notices:



**Indicates a hazardous situation which, if not avoided, will result in death or serious injury. Carefully read the message that follows to prevent serious injury or death.**



## WARNING

Indicates a hazardous situation which, if not avoided, could result in death or serious injury. Carefully read the message that follows to prevent serious injury or death.



## CAUTION

Indicates a hazardous situation which, if not avoided, could result in minor or moderate injury, or equipment damage or void the machine warranty. Carefully read the message that follows to prevent minor or moderate injury.

## NOTICE

Describes information that is useful but not safety related.



## WARNING

Multiple hazards.

Ignoring safety warnings may cause equipment damage, personal injury or death.

All possible safety hazards cannot be foreseen and included in this manual. The operator must always be alert to possible hazards that could endanger personnel or damage the equipment.

### 3.5 Labeling

- Change capacity, operation, and maintenance instruction plates, tags, or decals when a forklift truck is equipped with an attachment. If the truck is equipped with front-end attachments other than factory installed attachments, truck must be marked to identify the attachments and show the approximate weight of the truck and attachment combination at maximum elevation with load laterally centered.

### 3.6 Training

- Make sure all operators are trained in the fork and attachment adaptation, operation, and use limitations. Retrain an operator if a new attachment is added to the forklift. Consult the operator's manual for instructions on how to use the new equipment.
- Know the mechanical limitations of your forklift.

- Modifications or additions that affect capacity or safe operation must have prior written approval from the forklift truck manufacturer. Capacity, operation, and maintenance instruction plates, tags, or decals shall be changed accordingly.
- Never use free rigging for a below-the-forks lift. It could affect the capacity and safe operation of a lift truck.

### 3.7 Personnel Safety

- When removing or installing dismountable attachments always keep hands and feet free from dangerous positions or pinch points. Never leave a dismounted attachment in a dangerous position.
- Keep hands, feet, long hair and clothing away from power-driven parts. Do not wear loose fitting clothing or jewelry while performing maintenance and lubrication in these areas.
- Never jump on or off the machine.
- Never stand on top of material being raised, lowered, or transported. (Figure 3-1)

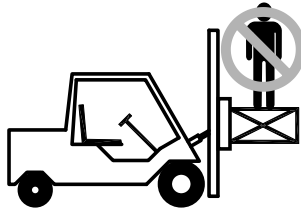

Figure 3-1,

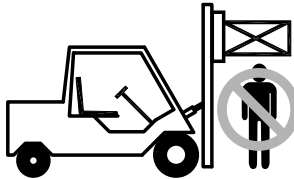

Figure 3-2,

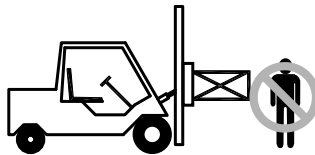

Figure 3-3,

- Never use the attachment or its load to support a man-carrying device.
- Never allow anyone under a load or under the carriage. (Figure 3-2)



- Never stand in front of or beside an attachment that is being operated. Never allow another person to approach an attachment that is being operated. (Figure 3-3)
- Never leave an attachment or load in an elevated position.
- Never reach through the mast of the truck. Keep all parts of the body within the driver's compartment.
- Always operate an attachment from the operator's seat, never while standing next to the lift truck.
- Do not allow riders on the truck at any time.
- Always use reverse when carrying a load that impedes full vision. Watch for pedestrians when transporting.
- Always use personal protective equipment (PPE) appropriate to the situation.

### **3.8 Pre-start Checks**

- Check your equipment before you operate it. If anything looks wrong, unusual or different, report it before using the attachment.
- Do not operate this machine if you know of malfunctions, missing parts, and/or mis-adjustments. These situations can cause or contribute to an accident or damage to the machine. Stop the machine immediately if problems arise after starting.
- Check to make sure the attachment on your truck is the same as on the truck capacity plate.
- Check for hydraulic leaks and cracked hoses or fittings. Check the hydraulic oil level in the lift truck hydraulic reservoir.
- All electrical cables and connectors must be in good condition. Use caution in wet weather to avoid danger from electrical shock.
- Always check the attachment for proper fit and engagement of the truck carriage.

### **3.9 Operation Warnings**

- You must be trained to operate this equipment prior to operation. Be extremely careful if you do not normally operate this machine. Reorient yourself to the machine before starting, then proceed slowly.
- Always operate an attachment from the driver's seat.
- Always lower the attachment if you need to leave the lift truck. A lift truck supporting a load requires your full attention.

### 3.10 Hydraulic Hazards



**Injection hazard.**

**Infection and gangrene will result when hydraulic oil penetrates the skin. See a doctor immediately to prevent loss of limb or death.**

**Use a piece of cardboard to check for hydraulic leaks.**

- Wear personal protective equipment, such as gloves and safety glasses, whenever servicing or checking a hydraulic system.
- Assume that all hydraulic hoses and components are pressurized. Relieve all hydraulic pressure before disconnecting any hydraulic line.
- Never try to stop or check for a hydraulic leak with any part of your body; use a piece of cardboard to check for hydraulic leaks.

### 3.11 Electrical Hazards



**Electrocution hazard.**

**Contact with energized equipment may result in injury or death and will damage equipment.**

**Remain at least 25 feet from high voltage electrical wires.**

- All electrical cables and connectors must be in good condition (free of corrosion, damage, etc). Use caution in wet weather to avoid danger from electrical shock. Never attempt electrical testing or repair while standing in water.
- Do not wear electrically conductive jewelry, clothing, or other items while working on the electrical system.

### 3.12 Maintenance Warnings

Maintenance, lubrication and repair of this machine can be dangerous unless performed properly. You must have the necessary skills and information, proper tools and equipment. Work in a method that is safe, correct, and meets your company's requirements.

- Do not attempt to make adjustments, or perform maintenance or service unless you are authorized and qualified to do so.

- Include attachments in a scheduled maintenance and inspection program. Tailor inspection steps to the attachment.
- Unless specified in service procedures, never attempt maintenance or lubrication procedures while the machine is moving or the engine is running.
- Always perform all maintenance and lubrication procedures with the machine on level ground, parked away from traffic lanes.

## NOTICE

**Local laws and regulations may require that additional safety measures be taken.**

- Never rely on the hydraulic system to support any part of the machine during maintenance or lubrication. Never stand under a component that is supported only by the hydraulics. Make sure it is resting on its mechanical stops or appropriate safety stands.
- Use caution when working around hot fluids. Always allow lubricating and hydraulic oils to cool before draining. Burns can be severe.
- Use extreme caution when using compressed air to blow parts dry. The pressure should not exceed 30 psi (208 kPa) at the nozzle. Never use compressed air on yourself. Air pressure penetrating your skin can be fatal.



## WARNING

**Suffocation hazard.**

**Engine exhaust fumes can cause death.**

**Remove the exhaust fumes from the area with an exhaust pipe extension, or use ventilation fans and open shop doors to provide adequate ventilation.**

- Before disconnecting hydraulic lines, be sure to lower all loads and relieve all hydraulic pressure. The load could fall on you, or escaping hydraulic oil could cause severe personal injury.
- Prevent personal injury or equipment damage by using a lifting device with a lifting capacity greater than twice the weight of any equipment to be lifted.

### 3.13 Load Handling

- Treat an unloaded forklift with an attachment as partially loaded.



**Equipment overload hazard.**

**Injury or equipment damage may result if the capacity of the truck and attachment combined are less than the attachment capacity.**

**Consult truck nameplate for truck capacity with an attachment installed.**

- Never overload the attachment. Refer to the attachment nameplate for the rated capacity of the attachment. Refer to the truck nameplate for the maximum net working capacity of the truck/attachment combination. Never use a load to support or move another object. Doing so can easily exceed the holding capacity of the attachment.
- Always check loads to be handled. Correct loads that are broken, unbalanced, loose, or too heavy.
- Never lift, lower, side shift, pivot, rotate, or tilt loads while traveling. Repositioning loads while traveling affects the stability of the truck and may impede vision or clearances.
- Do not use an attachment to open or close boxcar doors. Doing so can severely damage the attachment and cause loss of warranty. Damage to clamp arms may result in product damage.
- Do not carry loose items or unsupported loads on top of a clamped load.
- Never use chains, cables, or other devices in conjunction with an attachment for load handling.
- Never clamp loads other than what the attachment was designed to handle.
- Always carry cylindrically shaped loads in the vertical position, not the horizontal.
- Always clamp loads with the contact pads, if applicable, not the arm or arm base.
- Never rotate a load that is off center to the centerline of rotation. Severe damage to the rotator could result.
- Always ensure that the load is the same width as the pallet and neatly stacked when using a carton clamp.

### 3.14 Load Positioning

- Be accurate in load placement. It's important to know what the load will do when it's released.
- Always carry loads as close to the floor as possible, consistent with the surface being traversed. Scraping or bumping the floor surface with the load or the attachment can severely damage the attachment and cause product damage. The mast should be tilted back.
- Always keep the load positioned as close as possible to the horizontal center of the lift truck.
- Always back down ramps or inclines. Driving forward down a ramp or incline with a clamped load will lessen the stability of the truck. (Figure 3-4)

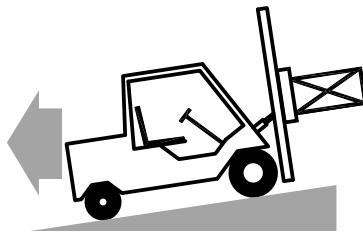

Figure 3-4,

- Do not cross dock boards or dock levelers with the attachment or carriage fully lowered. Ramming the front or rear of the attachment against a dock board can cause severe damage.
- Limit lift truck movement to a minimum when high stacking. Limit sideshift movement to a minimum when high stacking.
- Always be observant when high stacking. Look for poorly stacked loads, overhead obstacles, broken cartons, or damaged products in the stack.
- Travel slowly around corners. Sound horn on blind corners. Be careful of tail swing and overhead clearances. Watch in all directions. Avoid sudden stops.

### 3.15 Operator's Controls

Some lift trucks are equipped with a single lever to control both hoist and tilt functions, others have separate levers for each function. Refer to your lift truck manual for more information.

For clarity, the direction of arm movement is shown on the control handle. To move the arms in the direction shown, pull the handle towards the operator. To move the arms in the opposite direction, the push the handle away from the operator. (Figure 3-5)

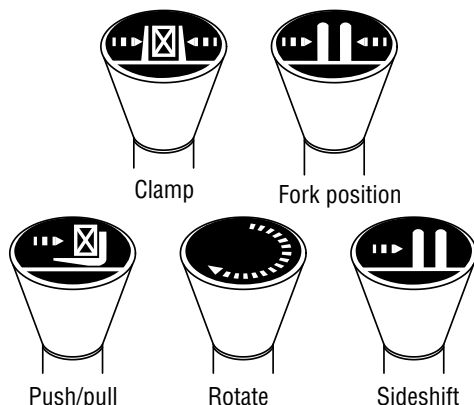

**Figure 3-5, Operator controls**

Lifting speed is controlled by the speed of the engine and the position of the control lever. Engine speed has no effect on lowering speed.

Before going on the job, shift the truck control levers one way and then the other to determine which direction the attachment moves when the levers are shifted. Make sure the attachment moves smoothly throughout its travel, without binding or pinching hoses.



**Equipment damage hazard.**

**Injury or equipment damage may result if the attachment does NOT operate smoothly.**

**Do not take malfunctioning equipment on the job. Check with your supervisor about needed repairs.**

### 3.16 Clamp Open Control

Effective October 7, 2010, safety standard ANSI/ITSDF B56.1, Section 7.25.7 covers all lift trucks with a load bearing clamp (paper roll clamp, carton clamp, etc.), and requires the driver to make two distinct motions before opening or releasing the clamp. For example, you must press a switch and then move a lever to unclamp the load. This requirement applies to new and used attachments being mounted on trucks which shipped from the factory after October 7, 2010, and is a recommended feature to be installed on dealer orders and existing applications.



# WARNING

Load loss hazard.

Injury or equipment/load damage may result if a fork positioner attachment is used to clamp a load. The fork positioner does not have enough clamping force to safely hold a load.

Always support the load with the forks. Do not use fork positioning attachments as clamps.

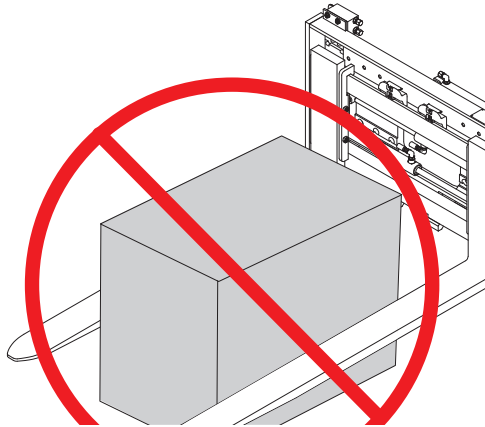

Figure 3-6, Do Not Clamp

## 3.17 Industry Standards

ANSI/ITSDF B56.1-2016 is the published sequence and direction standard for lever- and hand-type controls.

# NOTICE

The chart on the following page shows industry standards. Your equipment may be different. If you do not routinely operate this equipment, refresher training is recommended. You must reacquaint yourself with this manual and the equipment before starting, and then proceed slowly.

Special controls such as automatic devices should be identified, preferably according to the recommendations in Figure 3-7.

When a function is controlled by a pair of push buttons, they should operate in the same sense as the lever controls. For example, pushing a button located to the rear (relative to the operator's position) should serve the same function as moving a control lever to the rear.

Function	Direction of motion	
	Load	Operator's hand on control handle, facing the load*
Hoist	Up Down	Rearward or up Forward or down
Reach	Retract Extend	Rearward or up** Forward or down
Tilt	Rearward Forward	Rearward or up** Forward or down
Sideshift	Right Left	Rearward or up Forward or down
Push-pull	Rearward Forward	Rearward or up** Forward or down
Rotate, lateral	Clockwise Counterclockwise	Rearward or up Forward or down
Rotate, longitude	Rearward Forward	Rearward or up Forward or down
Load stabilizer	Down Up	Rearward or up Forward or down
Swing	Right Left	Rearward or up Forward or down
Slope	Clockwise Counterclockwise	Rearward or up Forward or down
Fork position	Together Apart	Rearward or up Forward or down
Trip	Engage Release	Rearward or up Forward or down
Grip	Engage Release	Rearward or up Forward or down
Truck stabilizer	Raise Lower	Rearward or up Forward or down
Clamp	Clamp Release	Rearward or up Forward or down

**Figure 3-7, ANSI/ITSDF**

**Sequence of location and direction of motion for lever- or hand-type controls**

- \* For high lift order picker trucks and center control pallet trucks, predominant motion of the operator's hand when actuating the control handle while facing away from the load.
- \*\* The sense of rotation of the control handle is intended to be in the same direction as the desired motion of the mast or load.



## SECTION 4 INSTALLATION PROCEDURE

### 4.1 Truck Requirements

Long Reach attachments have been designed to operate within specific limits. Operating pressures above the recommended maximum may cause damage to the attachment and may void the warranty. Operating pressure specifications for your attachment can be found on the attachment nameplate. (Section 1)

Hydraulic flow less than the recommended rates, or the use of small I.D. hoses may reduce operating speed. Higher flow can result in excessive heat buildup, erratic operation and damage to the truck/attachment hydraulic system. Hydraulic flow specifications for your attachment can be found on the attachment nameplate. (Section 1)

## NOTICE

**The dealer and/or the user must provide and install the valving required to meet the recommended hydraulic pressures and flow, or must arrange installation of the required valving at the truck factory.**

**The attachment model description, found on your shipped invoice, will state the following truck requirements: flow (gpm), psi, and minimum truck carriage width.**

1. The truck carriage must conform to the American National Standard (ANSI) dimensions shown in ANSI/ITSDF B56.11.4-2013.
2. Make sure the truck carriage is clean, conforms to ANSI recommendations, and the notches are not damaged.
3. The truck hydraulic system must supply to the attachment hydraulic oil that meets the specifications required to operate the attachment properly.
4. Find specifications for your attachment on the attachment nameplate. (Section 1)

## 4.2 Attachment Installation

1. Prior to connecting the truck to the attachment, clear an area to install safely the attachment.



# WARNING

Equipment overload hazard.

Overloading the truck may cause equipment damage.

Consult truck nameplate to determine the capacity of the truck and attachment combination, as it may be less than the capacity shown on the attachment alone.

### 4.2.1 Bolt-On Hooks

First, remove the lower bolt-on hooks and, if applicable, make a note of any factory-installed shims. Shims are used to create space between the hook and carriage.

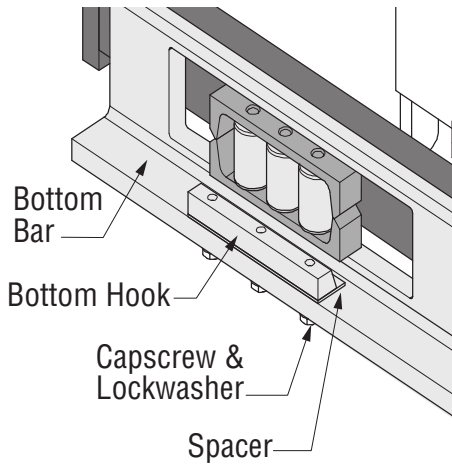

Figure 4-1, Remove the bottom bolt-on hooks

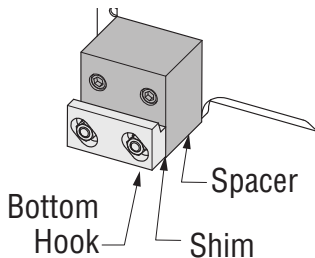
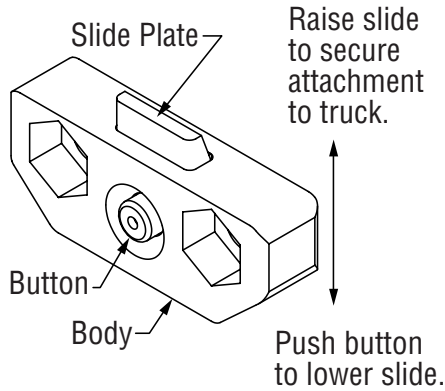

Figure 4-2, Remove the bottom bolt-on hooks

## 4.2.2 Quick Hooks

There are two kinds of quick hook, detent-pin style and push-button style.



**Figure 4-3, Push-button style quick hook**

For push button quick hooks, depress the button on the back of the hook and allow the slide plate to drop. (Figure 4-3)

Removing push button quick hooks is NOT recommended.

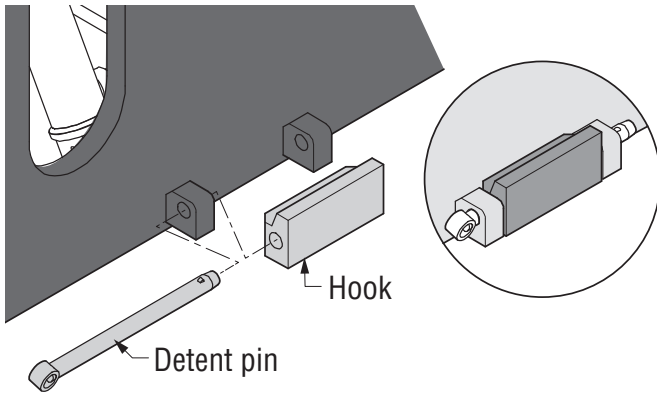
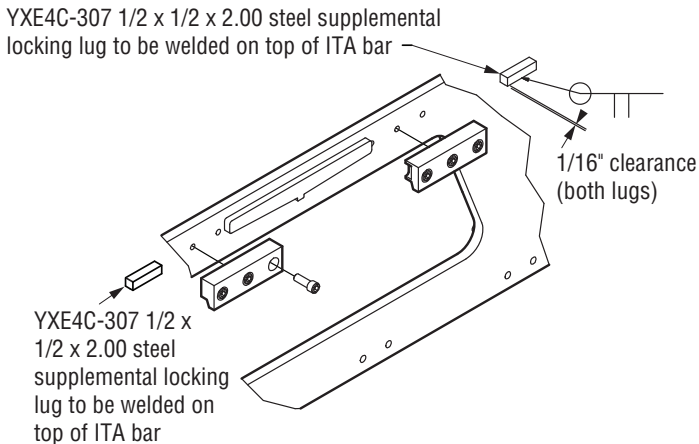

**Figure 4-4, Detent pin style quick hook**

For detent-pin style quick hooks, just pull the pin and remove it. The hook will come loose (Figure 4-4).

### 4.3 Installations with Bolt-On Hooks

1. Center the truck behind the attachment and drive toward it with the mast tilted forward about 4 degrees.
2. Line up the locking lug (if equipped) with the notch closest to the center on the truck's carriage.
3. Raise the truck carriage completely to engage the top hooks with the truck carriage. Tilt carriage back until the unit is against the carriage bottom fork bar (0 degrees).
4. Inspect for proper engagement of the locking lug in the notch that puts the attachment closest to the center of the truck's carriage.
5. Weld on the supplemental locking lug that is supplied with the attachment with either E-6011 or E-6013 welding rod or equivalent on each side of the truck carriage. Locking lugs are not required for side-shifting units with midplates. (Figure 4-5)



**Figure 4-5, Welding the optional locking lug**

6. Install the bolt-on lower hooks. Check the clearance between the carriage and the lower hooks. Loosen the bolts on the front of the hooks, and slide them up or down so the clearance is no more than 3/32".

On Class II and Class III units, tighten the 3/8" bolts to 33 ft-lbs. On Class IV units tighten the 1/2" bolts to 77 ft-lbs. On units using 9/16" UNC bolts, tighten the bolts to 112 ft-lbs.

## NOTICE

**Make note of any factory-installed spacers or shims. Shims are used to create clearance between the hook and carriage.**

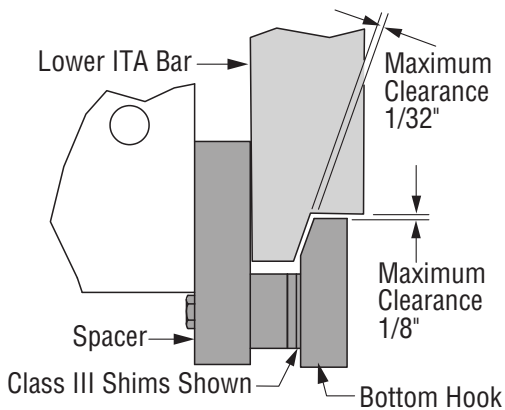

**Figure 4-6, Adjusting bolt-on bottom hooks with spacers**

#### 4.4 Installations with Quick Hooks

1. Follow steps 1-5 under bolt-on hooks.

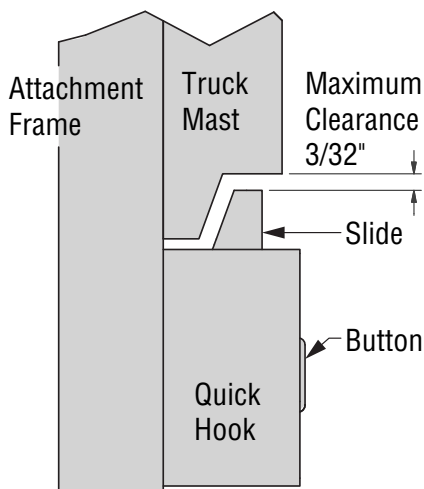

**Figure 4-7, Quick hook inspection**

2. Raise the slide plate until the button clicks into place.



# WARNING

**Equipment failure hazard.**

**The attachment could fall off the truck if the quick hook is not properly installed.**

**Slide plate must click into place. If the slide plate does not click into place because the truck carriage prevents the slide plate from being raised up high enough, install shims between the attachment and the body of the quick hooks.**

3. Check all connections and bolts for any interference.

## SECTION 5 SERVICE PROCEDURE

### 5.1 Attachment Removal

1. Secure truck in a safe removal area.



**Before disconnecting be sure to turn off the truck's power and apply safety brake.**

2. Slightly raise the truck carriage to allow the removal of the bottom mounting hooks. If the attachment is equipped with quick hooks (button-type), simply press the slide plate release button and drop the slide plate down (Figure 5-1).

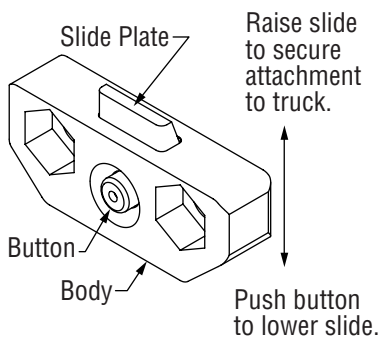

**Figure 5-1, Button-Type Quick Hook**

Removing push button quick hooks is NOT recommended.

If the attachment is equipped with pin-type quick hooks, simply remove the retaining pin and the quick hook. (Figure 5-2)

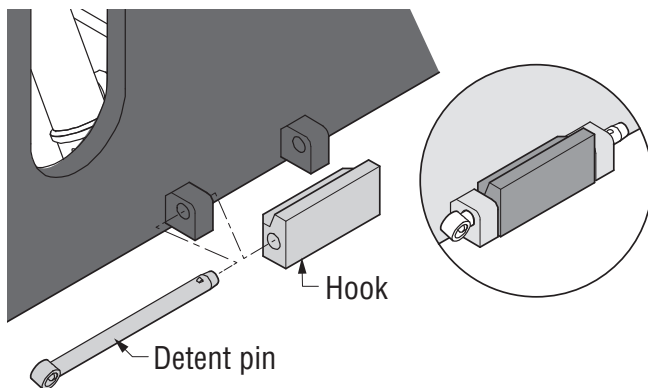

**Figure 5-2, Pin-Type Quick Hook**

3. Position the attachment on the edge of a pallet. Lower the attachment so that the lower carriage bar misses the pallet when lowered. Tilt the mast forward to allow the carriage to disengage from the upper mounting hooks and back away. If lowering onto a floor, blocks of wood can be placed under the body of the attachment to raise the rear.
4. To reinstall, follow the installation procedure in this manual.



**Equipment failure hazard.**

**The attachment could fall off the truck if the quick hook is not properly installed.**

**Slide plate must click into place. If the slide plate does not click into place because the truck carriage prevents the slide plate from being raised up high enough, install shims between the attachment and the body of the quick hooks.**



## SECTION 6 MAINTENANCE

### 6.1 Schedule

#### Daily:

1. If the attachment is equipped with quick change hooks check the slide plate latch or retainer pin (if used) for engagement.
2. Visually inspect for external damage or cracks.

#### 40 Hour Maintenance:

1. Inspect any forks that contact the ground. The fork blade and shank must be thoroughly checked for wear, especially near the heel. Reference Form 45-038 Fork Wear Inspection for instructions.

#### 250 Hours:

1. Check bolt torques and re-torque if necessary.
2. Inspect all welds and joints for damage or cracking.

### 6.2 Torque Specifications

The following torque values are to be used on all fasteners unless otherwise specified.

Lubricated refers to fasteners in the “As Received” condition, which is normally a light preservative oil coating on unplated fasteners and no oil coating on plated fasteners. No special steps are taken to add further lubrication prior to assembly.

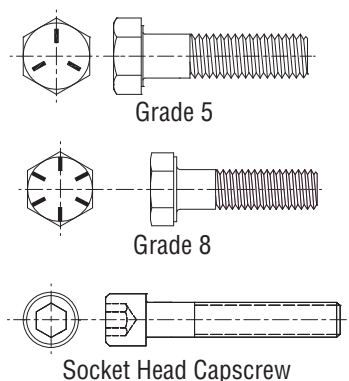

Figure 6-1, Bolt Identification

GRADE 8 COARSE THREAD		GRADE 5 COARSE THREAD		SOCKET HEAD COARSE THREAD	
Bolt Size	Lubricated Torque	Bolt Size	Lubricated Torque	Capscrew Size	Lubricated Torque
1/4"	11 ft-lbs	1/4"	7.5 ft-lbs	1/4"	12.5 ft-lbs
5/16"	23	5/16"	16	5/16"	26
3/8"	40	3/8"	28	3/8"	46
7/16"	63	7/16"	45	7/16"	74
1/2"	96	1/2"	68	1/2"	115
9/16"	140	9/16"	98	9/16"	160
5/8"	195	5/8"	140	5/8"	215
3/4"	340	3/4"	240	3/4"	385
7/8"	550	7/8"	390	7/8"	615
1"	820	1"	580	1"	920
1-1/8"	1,160	1-1/8"	715	1-1/8"	1,305
1-1/4"	1,640	1-1/4"	1,010	1-1/4"	1,840
1-3/8"	2,150	1-3/8"	1,330	1-3/8"	2,415
1-1/2"	2,850	1-1/2"	1,760	1-1/2"	3,205

Figure 6-2, Torque Specification

THIS PAGE WAS INTENTIONALLY LEFT BLANK

Find the latest version of your  
**complete** parts documentation  
in the **Manuals and  
Publications** tab at  
**[www.alliedsystems.com](http://www.alliedsystems.com)**.

[www.alliedsystems.com](http://www.alliedsystems.com)  
21433 Oregon Street, Sherwood, OR 97140, USA  
Phone: 800.285.7000 Fax: 800.231.3273