



Installation, Maintenance and Service Manual CPR, NPR, KPR, KTR

Paper Roll Clamps

THIS PAGE WAS INTENTIONALLY LEFT BLANK

TABLE OF CONTENTS

SECTION 1 NAMEPLATE LOCATION .	4	SECTION 5 SERVICE PROCEDURES	24
SECTION 2 MODEL NUMBER DESCRIPTION	5	5.1 General.....	24
SECTION 3 SAFETY SUMMARY	6	5.2 Pinion/Ring Gear and Bearing..	24
3.1 Safety Information.....	6	5.3 Bearing Seal Replacement.....	25
3.2 Product Modifications.....	6	5.4 Oil-Filled Gearboxes	26
3.3 Safety Regulations.....	6	5.5 Grease-Filled Gearboxes	30
3.4 Safety Symbols.....	6	5.6 Motor Disassembly	37
3.5 Labeling	7	5.7 Motor Assembly	40
3.6 Training	7	5.8 Cylinder Removal.....	47
3.7 Personnel Safety.....	8	5.9 Cylinder Disassembly	47
3.8 Pre-start Checks	9	5.10 Cylinder Inspection	49
3.9 Operation Warnings.....	9	5.11 Cylinder Assembly.....	50
3.10 Hydraulic Hazards	9	5.12 Cylinder Installation	51
3.11 Electrical Hazards	10	5.13 Swivel Assembly Removal	52
3.12 Maintenance Warnings	10	5.14 Swivel Assembly Installation ...	52
3.13 Load Handling.....	11	5.15 Stop Link Adjustment	52
3.14 Load Positioning	12	5.16 Attachment Removal	54
3.15 Operator's Controls	13	SECTION 6 MAINTENANCE	56
3.16 Clamp Open Control	14	6.1 Schedule.....	56
3.17 Industry Standards.....	14	6.2 Torque Specifications.....	58
SECTION 4 INSTALLATION PROCEDURE	16		
4.1 Truck Requirements	16		
4.2 Attachment Installation.....	17		
4.3 Hydraulic Connections.....	20		
4.4 Reusable Hose Fittings.....	21		
4.4.1 Remove Fitting.....	21		
4.4.2 Fitting Assembly.....	22		
4.5 Arm Movement	23		

SECTION 1 NAMEPLATE LOCATION

Notice

When you receive your attachment, locate the Long Reach nameplate (upper left corner on the body). Record the information from the nameplate, along with the date received, at the bottom of this page.

If the nameplate is missing, look for the serial number stamped directly into the metal at the nameplate location and consult the factory for details.

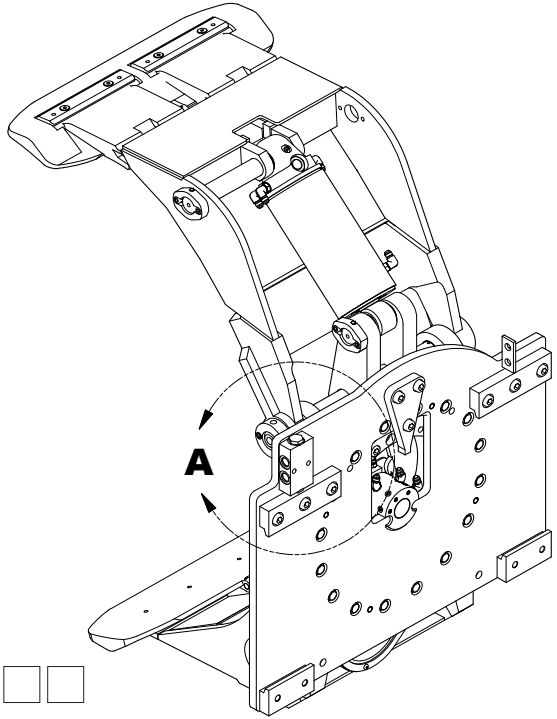

Date received:

- -

LONG REACH		A Division of Allied Systems Company		21433 SW Oregon Street Sherwood OR 97140 USA www.alliedsystems.com		2500005 rF	
MODEL NO.:	<input style="width: 100%;" type="text"/>			SERIAL NO.:	<input style="width: 100%;" type="text"/>		
CAPACITY AT LOAD CENTER:	<input style="width: 50px;" type="text"/> KG @ <input style="width: 50px;" type="text"/> MM	MASS:	<input style="width: 50px;" type="text"/> KG	AET:	<input style="width: 50px;" type="text"/> MM		
	<input style="width: 50px;" type="text"/> (LBS) @ <input style="width: 50px;" type="text"/> (IN)		<input style="width: 50px;" type="text"/> (LBS)		<input style="width: 50px;" type="text"/> (IN)		
MAXIMUM HYDRAULIC PRESSURE:	<input style="width: 50px;" type="text"/> BAR	FLOW:	<input style="width: 50px;" type="text"/> L/min	HCG:	<input style="width: 50px;" type="text"/> MM	VCG:	<input style="width: 50px;" type="text"/> MM
	<input style="width: 50px;" type="text"/> (PSI)		<input style="width: 50px;" type="text"/> (GPM)		<input style="width: 50px;" type="text"/> (IN)		<input style="width: 50px;" type="text"/> (IN)
DATE:	<input style="width: 100%;" type="text"/>			SEE TRUCK NAMEPLATE FOR COMBINED TRUCK & ATTACHMENT CAPACITY			

SECTION 2 MODEL NUMBER DESCRIPTION

Each attachment is identified by a model number and a serial number located on the nameplate attached to the unit prior to shipment. Long Reach's model numbers are designed to describe how an attachment is equipped. The guide below illustrates the information that is represented in a multi-digit model number. Always include model and serial number when ordering parts or requesting service information.

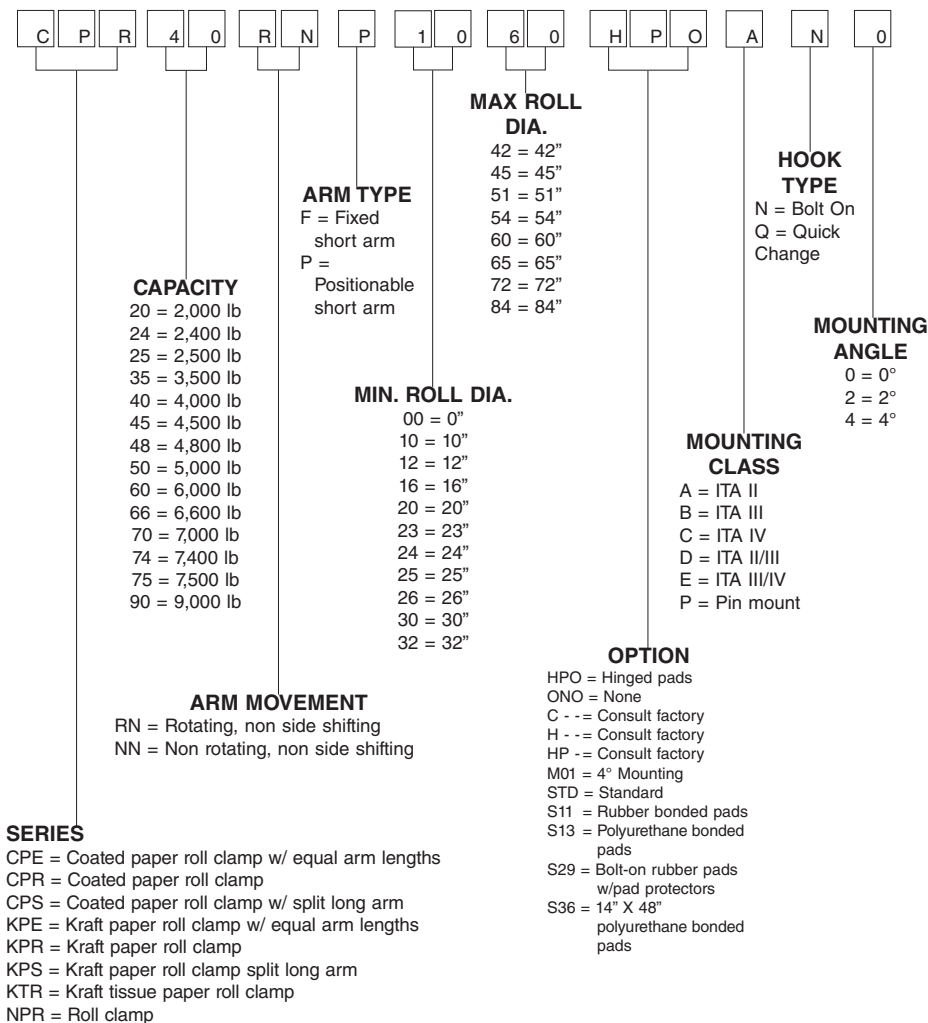

Note:

Weld = Weld cylinder anchor on the back of fork

No-weld = Supplied fork carrier

SECTION 3 SAFETY SUMMARY

3.1 Safety Information

Safety is Everyone's Responsibility

Whether you are new on the job or a seasoned veteran, these safety tips may prevent injury to you, to others, or to the materials you are handling. Always be alert, watch out for others, and follow these suggestions:

Attachments handle material, not people.

Safety starts with common sense, good judgment, properly maintained equipment, careful operation, and properly trained operators.

The safety instructions and warnings, as documented in this manual and shipped with the machine, provide the most reliable procedures for the safe operation and maintenance of your Long Reach attachment. It's your responsibility to see that they are carried out.

3.2 Product Modifications

Any alterations to the product, that have not been approved by Allied Systems Company or use of any non-OEM replacement parts will void the warranty, and may introduce serious safety hazards. Any non-OEM parts used, or any alterations made are done so at your own risk to personnel safety. This includes the addition of accessories and attachments not manufactured by Allied Systems Company.

3.3 Safety Regulations

Know your company's safety rules. Some companies have site-specific directions and procedures. The methods outlined in your operator's manual provide a basis for safe operation of the machine. Because of special conditions, your company's material handling procedures may be somewhat different from those shown in this manual.

3.4 Safety Symbols

The following terms define the various precautions and notices:



DANGER

Indicates a hazardous situation which, if not avoided, will result in death or serious injury. Carefully read the message that follows to prevent serious injury or death.



WARNING

Indicates a hazardous situation which, if not avoided, could result in death or serious injury. Carefully read the message that follows to prevent serious injury or death.

CAUTION

Indicates a hazardous situation which, if not avoided, could result in minor or moderate injury, or equipment damage or void the machine warranty. Carefully read the message that follows to prevent minor or moderate injury.

Notice

Describes information that is useful but not safety related.

WARNING

Multiple hazards.

Ignoring safety warnings may cause equipment damage, personal injury or death.

All possible safety hazards cannot be foreseen and included in this manual. The operator must always be alert to possible hazards that could endanger personnel or damage the equipment.

3.5 Labeling

- Change capacity, operation, and maintenance instruction plates, tags, or decals when a forklift truck is equipped with an attachment. If the truck is equipped with front-end attachments other than factory installed attachments, truck must be marked to identify the attachments and show the approximate weight of the truck and attachment combination at maximum elevation with load laterally centered.

3.6 Training

- Make sure all operators are trained in the fork and attachment adaptation, operation, and use limitations. Retrain an operator if a new attachment is added to the forklift. Consult the operator's manual for instructions on how to use the new equipment.
- Know the mechanical limitations of your forklift.
- Modifications or additions that affect capacity or safe operation must have prior written approval from the forklift truck manufacturer. Capacity, operation, and maintenance instruction plates, tags, or decals shall be changed accordingly.
- Never use free rigging for a below-the-forks lift. It could affect the capacity and safe operation of a lift truck.

3.7 Personnel Safety

- When removing or installing dismountable attachments always keep hands and feet free from dangerous positions or pinch points. Never leave a dismounted attachment in a dangerous position.
- Keep hands, feet, long hair and clothing away from power-driven parts. Do not wear loose fitting clothing or jewelry while performing maintenance and lubrication in these areas.
- Never jump on or off the machine.
- Never stand on top of material being raised, lowered, or transported. (Figure 3-1)

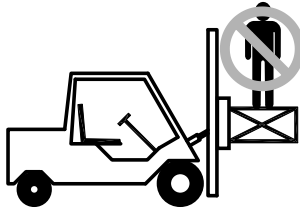

Figure 3-1,

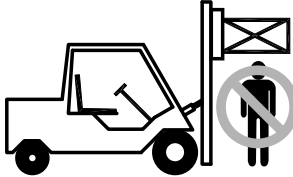

Figure 3-2,

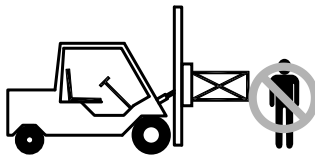

Figure 3-3,

- Never use the attachment or its load to support a man-carrying device.
- Never allow anyone under a load or under the carriage. (Figure 3-2)
- Never stand in front of or beside an attachment that is being operated. Never allow another person to approach an attachment that is being operated. (Figure 3-3)
- Never leave an attachment or load in an elevated position.
- Never reach through the mast of the truck. Keep all parts of the body within the driver's compartment.

- Always operate an attachment from the operator's seat, never while standing next to the lift truck.
- Do not allow riders on the truck at any time.
- Always use reverse when carrying a load that impedes full vision. Watch for pedestrians when transporting.
- Always use personal protective equipment (PPE) appropriate to the situation.

3.8 Pre-start Checks

- Check your equipment before you operate it. If anything looks wrong, unusual or different, report it before using the attachment.
- Do not operate this machine if you know of malfunctions, missing parts, and/or mis-adjustments. These situations can cause or contribute to an accident or damage to the machine. Stop the machine immediately if problems arise after starting.
- Check to make sure the attachment on your truck is the same as on the truck capacity plate.
- Check for hydraulic leaks and cracked hoses or fittings. Check the hydraulic oil level in the lift truck hydraulic reservoir.
- All electrical cables and connectors must be in good condition. Use caution in wet weather to avoid danger from electrical shock.
- Always check the attachment for proper fit and engagement of the truck carriage.

3.9 Operation Warnings

- You must be trained to operate this equipment prior to operation. Be extremely careful if you do not normally operate this machine. Reorient yourself to the machine before starting, then proceed slowly.
- Always operate an attachment from the driver's seat.
- Always lower the attachment if you need to leave the lift truck. A lift truck supporting a load requires your full attention.

3.10 Hydraulic Hazards



DANGER

Injection hazard.

Infection and gangrene will result when hydraulic oil penetrates the skin. See a doctor immediately to prevent loss of limb or death.

Use a piece of cardboard to check for hydraulic leaks.

- Wear personal protective equipment, such as gloves and safety glasses, whenever servicing or checking a hydraulic system.
- Assume that all hydraulic hoses and components are pressurized. Relieve all hydraulic pressure before disconnecting any hydraulic line.
- Never try to stop or check for a hydraulic leak with any part of your body; use a piece of cardboard to check for hydraulic leaks.

3.11 Electrical Hazards



WARNING

Electrocution hazard.

Contact with energized equipment may result in injury or death and will damage equipment.

Remain at least 25 feet from high voltage electrical wires.

- All electrical cables and connectors must be in good condition (free of corrosion, damage, etc). Use caution in wet weather to avoid danger from electrical shock. Never attempt electrical testing or repair while standing in water.
- Do not wear electrically conductive jewelry, clothing, or other items while working on the electrical system.

3.12 Maintenance Warnings

Maintenance, lubrication and repair of this machine can be dangerous unless performed properly. You must have the necessary skills and information, proper tools and equipment. Work in a method that is safe, correct, and meets your company's requirements.

- Do not attempt to make adjustments, or perform maintenance or service unless you are authorized and qualified to do so.
- Include attachments in a scheduled maintenance and inspection program. Tailor inspection steps to the attachment.
- Unless specified in service procedures, never attempt maintenance or lubrication procedures while the machine is moving or the engine is running.
- Always perform all maintenance and lubrication procedures with the machine on level ground, parked away from traffic lanes.

Notice

Local laws and regulations may require that additional safety measures be taken.

- Never rely on the hydraulic system to support any part of the machine during maintenance or lubrication. Never stand under a component that is supported only by the hydraulics. Make sure it is resting on its mechanical stops or appropriate safety stands.
- Use caution when working around hot fluids. Always allow lubricating and hydraulic oils to cool before draining. Burns can be severe.
- Use extreme caution when using compressed air to blow parts dry. The pressure should not exceed 30 psi (208 kPa) at the nozzle. Never use compressed air on yourself. Air pressure penetrating your skin can be fatal.



WARNING

Suffocation hazard.

Engine exhaust fumes can cause death.

Remove the exhaust fumes from the area with an exhaust pipe extension, or use ventilation fans and open shop doors to provide adequate ventilation.

- Before disconnecting hydraulic lines, be sure to lower all loads and relieve all hydraulic pressure. The load could fall on you, or escaping hydraulic oil could cause severe personal injury.
- Prevent personal injury or equipment damage by using a lifting device with a lifting capacity greater than twice the weight of any equipment to be lifted.

3.13 Load Handling

- Treat an unloaded forklift with an attachment as partially loaded.



CAUTION

Injury or equipment damage may result if the capacity of the truck and attachment combined are less than the attachment capacity.

Consult truck nameplate for truck capacity with an attachment installed.

- Never overload the attachment. Refer to the attachment nameplate for the rated capacity of the attachment. Refer to the truck nameplate for the maximum net working capacity of the truck/attachment combination. Never use a load to support or move another object. Doing so can easily exceed the holding capacity of the attachment.
- Always check loads to be handled. Correct loads that are broken, unbalanced, loose, or too heavy.

- Never lift, lower, side shift, pivot, rotate, or tilt loads while traveling. Repositioning loads while traveling affects the stability of the truck and may impede vision or clearances.
- Do not use an attachment to open or close boxcar doors. Doing so can severely damage the attachment and cause loss of warranty. Damage to clamp arms may result in product damage.
- Do not carry loose items or unsupported loads on top of a clamped load.
- Never use chains, cables, or other devices in conjunction with an attachment for load handling.
- Never clamp loads other than what the attachment was designed to handle.
- Always carry cylindrically shaped loads in the vertical position, not the horizontal.
- Always clamp loads with the contact pads, if applicable, not the arm or arm base.
- Never rotate a load that is off center to the centerline of rotation. Severe damage to the rotator could result.
- Always ensure that the load is the same width as the pallet and neatly stacked when using a carton clamp.

3.14 Load Positioning

- Be accurate in load placement. It's important to know what the load will do when it's released.
- Always carry loads as close to the floor as possible, consistent with the surface being traversed. Scraping or bumping the floor surface with the load or the attachment can severely damage the attachment and cause product damage. The mast should be tilted back.
- Always keep the load positioned as close as possible to the horizontal center of the lift truck.
- Always back down ramps or inclines. Driving forward down a ramp or incline with a clamped load will lessen the stability of the truck. (Figure 3-4)

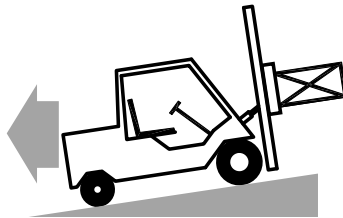

Figure 3-4,

- Do not cross dock boards or dock levelers with the attachment or carriage fully lowered. Ramming the front or rear of the attachment against a dock board can cause severe damage.
- Limit lift truck movement to a minimum when high stacking. Limit sideshift movement to a minimum when high stacking.
- Always be observant when high stacking. Look for poorly stacked loads, overhead obstacles, broken cartons, or damaged products in the stack.
- Travel slowly around corners. Sound horn on blind corners. Be careful of tail swing and overhead clearances. Watch in all directions. Avoid sudden stops.

3.15 Operator's Controls

Some lift trucks are equipped with a single lever to control both hoist and tilt functions, others have separate levers for each function. Refer to your lift truck manual for more information.

For clarity, the direction of arm movement is shown on the control handle. To move the arms in the direction shown, pull the handle towards the operator. To move the arms in the opposite direction, the push the handle away from the operator. (Figure 3-5)

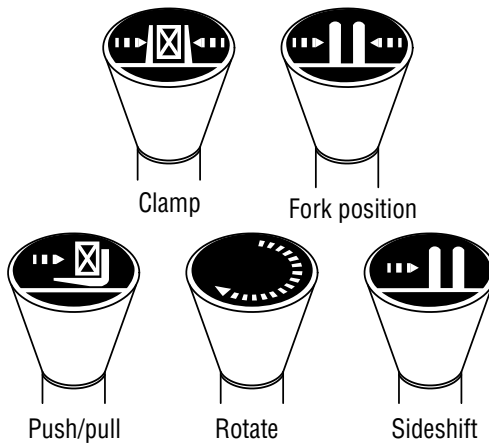

Figure 3-5, Operator controls

Lifting speed is controlled by the speed of the engine and the position of the control lever. Engine speed has no effect on lowering speed.

Before going on the job, shift the truck control levers one way and then the other to determine which direction the attachment moves when the levers are shifted. Make sure the attachment moves smoothly throughout its travel, without binding or pinching hoses.

CAUTION

Equipment damage hazard.

Injury or equipment damage may result if the attachment does NOT operate smoothly.

Do not take malfunctioning equipment on the job. Check with your supervisor about needed repairs.

3.16 Clamp Open Control

Effective October 7, 2010, safety standard ANSI/ITSDF B56.1, Section 7.25.7 covers all lift trucks with a load bearing clamp (paper roll clamp, carton clamp, etc.), and requires the driver to make two distinct motions before opening or releasing the clamp. For example, you must press a switch and then move a lever to unclamp the load. This requirement applies to new and used attachments being mounted on trucks which shipped from the factory after October 7, 2010, and is a recommended feature to be installed on dealer orders and existing applications.

3.17 Industry Standards

ANSI/ITSDF B56.1-2016 is the published sequence and direction standard for lever- and hand-type controls.

Notice

The chart on the following page shows industry standards. Your equipment may be different. If you do not routinely operate this equipment, refresher training is recommended. You must reacquaint yourself with this manual and the equipment before starting, and then proceed slowly.

Special controls such as automatic devices should be identified, preferably according to the recommendations in Figure 3-6.

When a function is controlled by a pair of push buttons, they should operate in the same sense as the lever controls. For example, pushing a button located to the rear (relative to the operator's position) should serve the same function as moving a control lever to the rear.

Function	Direction of motion	
	Load	Operator's hand on control handle, facing the load*
Hoist	Up Down	Rearward or up Forward or down
Reach	Retract Extend	Rearward or up** Forward or down
Tilt	Rearward Forward	Rearward or up** Forward or down
Sideshift	Right Left	Rearward or up Forward or down
Push-pull	Rearward Forward	Rearward or up** Forward or down
Rotate, lateral	Clockwise Counterclockwise	Rearward or up Forward or down
Rotate, longitude	Rearward Forward	Rearward or up Forward or down
Load stabilizer	Down Up	Rearward or up Forward or down
Swing	Right Left	Rearward or up Forward or down
Slope	Clockwise Counterclockwise	Rearward or up Forward or down
Fork position	Together Apart	Rearward or up Forward or down
Trip	Engage Release	Rearward or up Forward or down
Grip	Engage Release	Rearward or up Forward or down
Truck stabilizer	Raise Lower	Rearward or up Forward or down
Clamp	Clamp Release	Rearward or up Forward or down

Figure 3-6, ANSI/ITSDF

Sequence of location and direction of motion for lever- or hand-type controls

- * For high lift order picker trucks and center control pallet trucks, predominant motion of the operator's hand when actuating the control handle while facing away from the load.
- ** The sense of rotation of the control handle is intended to be in the same direction as the desired motion of the mast or load.

SECTION 4 INSTALLATION PROCEDURE

4.1 Truck Requirements

Long Reach attachments have been designed to operate within specific limits. Operating pressures above the recommended maximum may cause damage to the attachment and may void the warranty. Operating pressure specifications for your attachment can be found on the attachment nameplate. (Section 1)

Hydraulic flow less than the recommended rates, or the use of small I.D. hoses may reduce operating speed. Higher flow can result in excessive heat buildup, erratic operation and damage to the truck/attachment hydraulic system. Hydraulic flow specifications for your attachment can be found on the attachment nameplate. (Section 1)

Notice

The dealer and/or the user must provide and install the valving required to meet the recommended hydraulic pressures and flow, or must arrange installation of the required valving at the truck factory.

The attachment model description, found on your shipped invoice, will state the following truck requirements: flow (gpm), psi, and minimum truck carriage width.

Recommended hydraulic supplies are as follows:

	Min.	Max.	PSI
Class II	3.2	4.1	2,200 - 3,000
Class III	2.9	6.4	2,200 - 3,000
Class IV	4.0	12.0	2,200 - 3,000

1. The truck carriage must conform to the American National Standard (ANSI) dimensions shown in ANSI/ITSDF B56.11.4-2013.
2. Make sure the truck carriage is clean, conforms to ANSI recommendations, and the notches are not damaged.
3. The truck hydraulic system must supply to the attachment hydraulic oil that meets the specifications required to operate the attachment properly. Find specifications for your attachment on the attachment nameplate. (Section 1)
4. When the truck hydraulic system pressures (PSI) exceeds specified maximum, a relief valve is recommended in the attachment auxiliary system of the truck or on the attachment.

4.2 Attachment Installation

WARNING

Equipment overload hazard.

Overloading the truck may cause equipment damage.

Consult truck nameplate to determine the capacity of the truck and attachment combination, as it may be less than the capacity shown on the attachment alone.

1. Remove the lower bolt-on hooks and, if applicable, make a note of any factory installed shims. Shims are used to create clearance between the hook and carriage.

If the attachment is equipped with quick hooks, simply depress the button on the back of the hooks, allowing the slide plate to drop. Removing the quick hooks from the attachment is NOT recommended. (Figure 4-1)

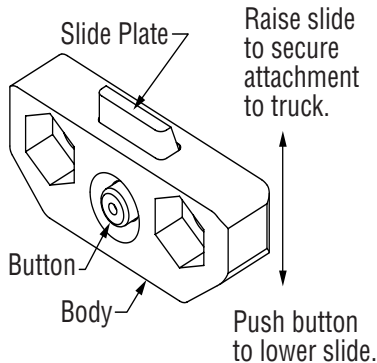

Figure 4-1, Quick hook

2. Center the truck behind the attachment and drive toward the attachment with the mast tilted forward approximately 4 degrees.
3. Line up the locking lug (under the hanger plate, if applicable) with the appropriate notch on the truck's carriage. Check that the bronze sideshifting wear strips are in the proper place, if applicable.

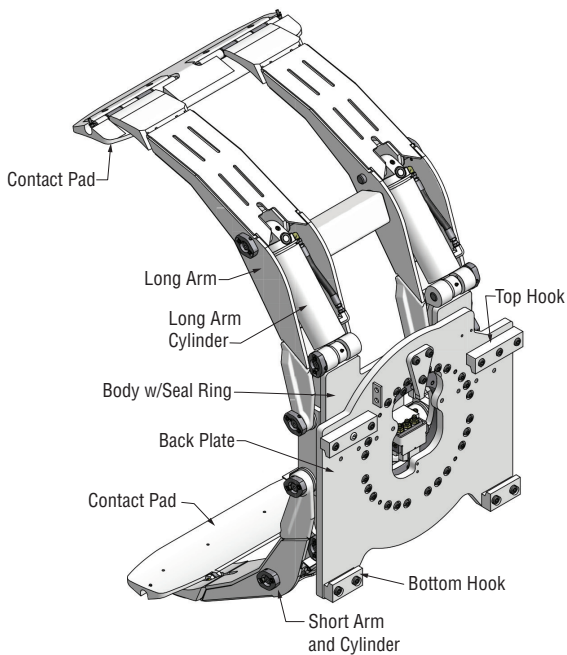
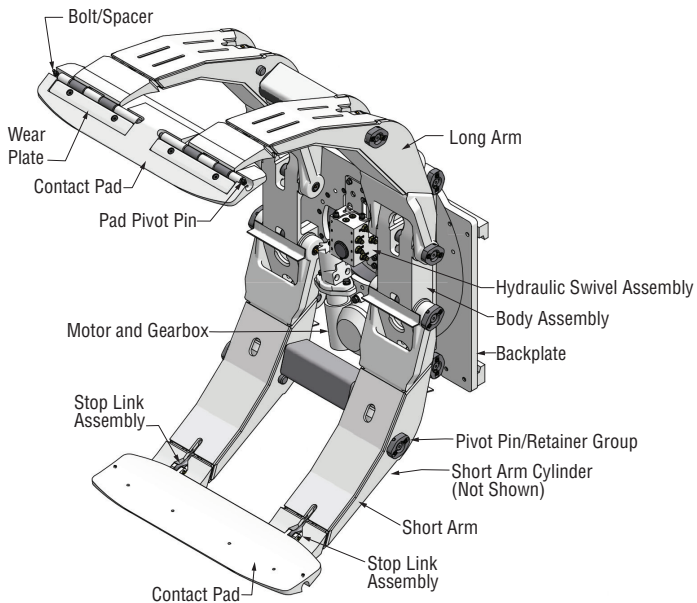

Figure 4-2, Major Assemblies

4. Slowly raise the truck carriage completely to engage the top hooks with the truck carriage. Tilt carriage back until the unit is against the carriage bottom fork bar (0 degrees).
5. Inspect for proper engagement of the locking lug in the corresponding notch of the truck's carriage. Inspect any wear strips, if applicable, to insure they are properly aligned in the top hooks.
6. Weld on the optional supplemental locking lug that is supplied with the attachment, (two pieces of 1/2 x 1/2 x 2.00 steel included with the attachment) with either E-6011 or E-6013 welding rod, or equivalent, on each side of the truck carriage. (Figure 4-3)

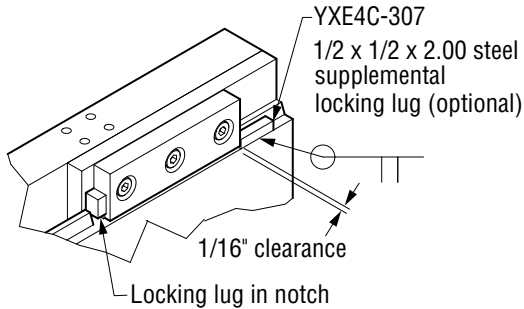

Figure 4-3, Locking Lug

7. Install the bolt-on lower hooks. Inspect clearance to the carriage on lower hooks. Adjust the lower hooks for a maximum clearance of $3/32$ " (see Figure 4-4). Tighten the bolts to the torque specifications on page 38 (Figure 6-3)

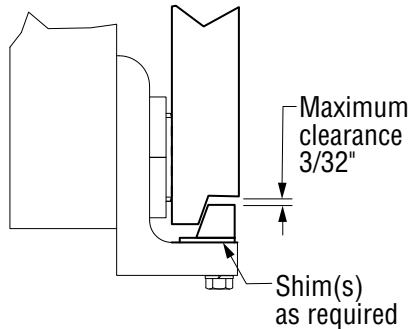

Figure 4-4, Lower Hook Clearance

8. If quick hooks are installed, simply raise the slide plate until the button clicks into place.

WARNING

Equipment failure hazard.

The attachment could fall off the truck if the quick hook is not properly installed.

Slide plate must click into place. If the slide plate does not click into place because the truck carriage prevents the slide plate from being raised up high enough, install shims between the attachment and the body of the quick hooks.

9. To ensure proper locking of the slide plate, use a screwdriver to try to pry down the slide plate. If the slide plate is not locked in place, inspect and correct any cause that might restrict the slide plate from going up enough to allow the button to become fully engaged.
10. Check all fittings, connections and bolts for any interference.

4.3 Hydraulic Connections

1. Prior to connecting the truck hydraulic system to the attachment, the system **must** be purged through the filtration system. This will eliminate any contamination that might exist in the auxiliary hydraulic system of the truck.
2. Purging can be accomplished by installing a jumper line and operating each hydraulic function (clamp, rotate and side shift if equipped) in each direction for a minimum of 30 seconds. (Figure 4-5)

Hoses should meet or exceed SAE100 RI Type AT, with maximum working pressure of 3,000 psi for all attachment functions.

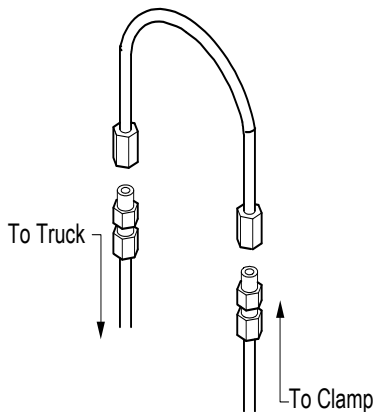

Figure 4-5, Jumper Line

3. Install the lines from the truck's hydraulics to the attachment's hydraulics. See Figure 5-42 for a general schematic. Refer to your parts manual for model specific hydraulic schematics and hose routing.
4. Inspect installation to ensure hoses are not kinked or pinched between the truck carriage and attachment.
5. After completing the installation, operate all functions of the attachment, without a load, for several cycles to remove any air in the hydraulic system. Test the attachment with a load to make sure the attachment operates correctly.
6. With the mast in the vertical position, rotate the attachment fully 360°. After this procedure, check that the truck's hydraulic reservoir oil level is at the recommended level.
7. Before placing the attachment in operation re-inspect all hoses and fittings for leaks and routing clearance. Be sure to include clearance of jumper hoses to the mast.

 **CAUTION**

Equipment damage hazard.

Equipment damage, performance reduction, personal injury and/or loss of warranty could result if any alterations are made to the original attachment.

Consult with factory before altering original equipment.

4.4 Reusable Hose Fittings

Kit hoses equipped with reusable fittings allow hoses to be cut to the exact length required for installation.

Notice

Do not shorten hoses to the point where they will be stretched or kinked when installed.

Make sure hoses are not pinched, rubbed, twisted, or otherwise damaged throughout their full range of movement. Use hose clamps to secure hoses if necessary.

4.4.1 Remove Fitting

To shorten a hose, remove the reusable end-fitting using the following procedures:

1. Clamp the fitting socket in a vise.

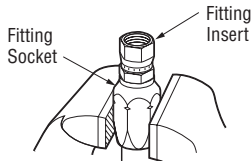

2. Unscrew the fitting insert from the fitting socket.

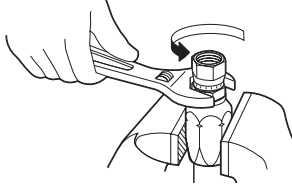

3. Unscrew the hose clockwise from the fitting socket.

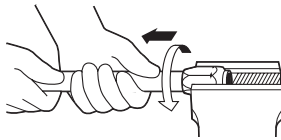

4.4.2 Fitting Assembly

1. The hose inserts into the fitting socket to the depth shown below and as indicated by the marks on the fitting wrench flats. Make sure the hose is not cut too short for proper installation. Cut the hose to the desired length using a fine toothed hacksaw or hose cutoff machine.

Hose Insertion Depth	
Hose Size	Screw hose in to:
No. 4	1 in. (25 mm)
No. 6	1.15 in. (29 mm)
No. 8	1.18 in. (30 mm)

2. Lubricate the fitting insert and the inside diameter of the hose.
3. Measure from the end of the hose and mark the hose insertion depth using the marks on the wrench flats or the table above.
4. Screw the hose into the fitting socket counterclockwise to the hose insertion depth mark.

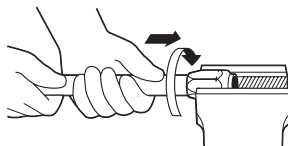

5. Screw the fitting insert into the fitting socket until it touches the socket.

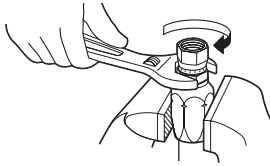

Notice

Inspect the hose for proper assembly. Look inside the fitting for hose material that might prevent free flow. Use compressed air to clear the hose of debris.

If the hose is damaged, remove the fitting and cut away the damaged hose. Reassemble the hose as in Fitting Assembly Steps 1 through 4.

4.5 Arm Movement

1. Arm movement is controlled by the position and sequence function of the swivel valve. (Figure 4-6)

Notice

Boundaries are not as exact as shown. Arms will move more slowly the closer they are to the dead band.

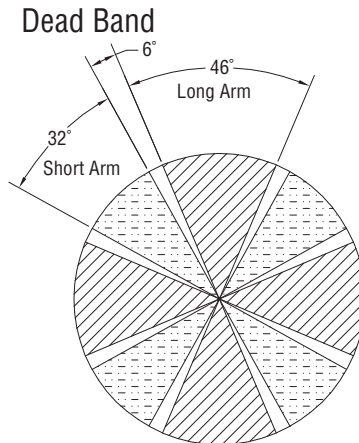

Figure 4-6, Arm Movement

2. Positioning of the long arm is allowed in all positions.
3. Positioning of the short arm will be allowed as shown in Figure 4-6.

SECTION 5 SERVICE PROCEDURE

5.1 General

Not all procedures require that the attachment be removed from the truck. Review each procedure before beginning. Make sure lifting equipment is rated for the load being lifted.

5.2 Pinion/Ring Gear and Bearing

1. Grease the pinion/ring gear every 40 hours. Grease the ring gear bearings every 100 hours. (See Section 6)

CAUTION

Equipment damage hazard.

Gears may wear out prematurely if not properly greased. Worn gears may affect performance or safety and result in loss of warranty.

Grease gears with recommended lubricant as described.

2. Grease the pinion/ring gear with Mobil lubricating grease NLGI grade EP2 ISO 220 or equivalent.
3. Grease the ring gear bearings with Aeroshell 22 grease or equivalent.
4. To ensure proper greasing of gears and bearings, slowly rotate the ring gear 360° while greasing. This will allow grease to completely coat the gear. Gears must be fully greased, (Figure 5-1). Also see Figure 6-1 for grease zerk locations.

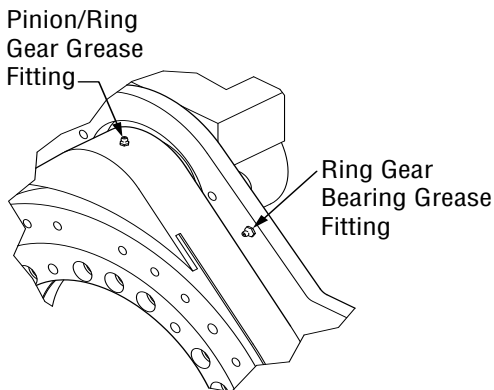

Figure 5-1, Grease Fitting Locations

5.3 Bearing Seal Replacement

Notice

Equipment damage hazard.

Foreign matter in the bearing could cause bearing failure.

Prevent any foreign matter from falling into the bearing during the seal replacement procedure.

1. Remove all traces of glue and the old seal from the seal groove by mechanically scraping the groove.
2. Clean the groove with a no-residue commercial solvent (trichloroethylene) to remove any trace of oil or grease.
3. Wipe the seal with the same solvent to insure cleanliness.
4. Apply a bead of adhesive to the back of the seal groove. Use enough adhesive to coat the seal on all three surfaces contacting the groove.

Notice

Equipment damage hazard.

Foreign matter in the bearing could cause bearing failure.

Keep adhesive from being extruded into the bearing SEPARATION LINE as the seal is installed.

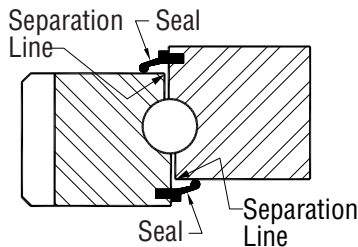

Figure 5-2, Bearing Seal

5. Insert the seal into the groove with firm steady pressure, but avoid stretching the seal.
6. The length of the seal provided is longer than required. Before gluing the last six inches, insert the seal into the groove to determine the exact length required. Trim the excess with a sharp knife so it smoothly meets the adjoining end.

7. Place a drop of super-glue on the end already in the bearing so that the two ends will be joined.
8. Allow ten minutes for the glue to cure.
9. Re-grease the bearing until grease squeezes out from under the seal to remove any foreign matter that might have become lodged in the bearing separation line.

5.4 Oil-Filled Gearboxes

5.4.1 Lubrication for Part Numbers: YGC-29, YGC-32, YGC-43 and YGC-43-LH

1. Remove the top plug and the oil level plug from the gearbox. (Figure 5-3)

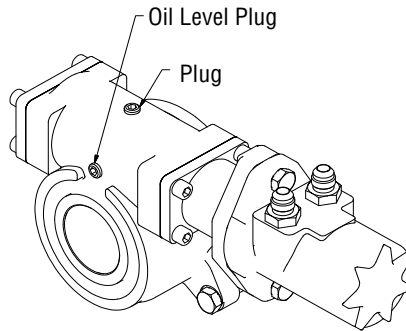

Figure 5-3, Gearbox Oil Plugs

2. Use Mobil HD 85W140 or equivalent oil. For temperatures below -20° F, use Mobil SHC 634 or equivalent synthetic oil.

Notice

Equipment damage hazard.

Overfilling the gearbox may damage the gearbox, causing a leak.

Do not overfill gearbox with oil.

3. Fill the gearbox to the oil level plug location.
4. The oil level should be checked occasionally at the oil level plug. If the oil level has dropped, a leak may have occurred. The leak should be corrected and the oil should be leveled off to the oil level plug location.
5. Reinstall plugs.

5.4.2 Disassembly for Part Numbers: YGC-29, YGC-32, YGC-43 and YGC-43-LH

1. Remove the attachment from truck. See Section 5-16.
2. Before removing the gearbox from the back plate, place a support overhead or under the gearbox. Remove the mounting capscrews from the gearbox. (Figure 5-4)

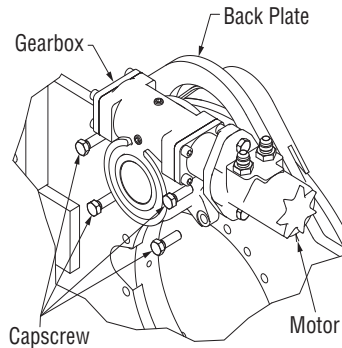

Figure 5-4, Gearbox Removal

3. Place the gearbox on a flat surface and remove the motor mounting capscrews. Note: Coupling fits loosely and may slide out. (Figure 5-5)

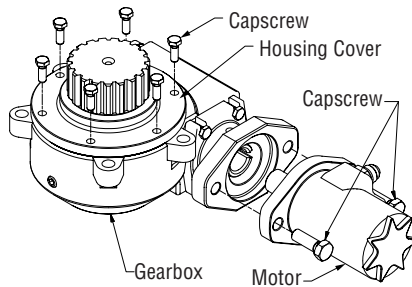

Figure 5-5, Motor Removal

4. Remove the pinion gear and key from the output shaft. Use a screwdriver to knock the key loose. (Figure 5-6)

Notice

Equipment damage hazard.

Impact wrenches could damage screws or sockets if screws have been secured with Loctite.

Use care when working with the gear assembly. Do not use a impact wrench on the screws that have been secured with Loctite.

Notice

Oil Leak Hazard.

Removing the adapter plate without draining the oil can result in a large oil spill.

Drain oil from the gearbox before removing the adapter plate.

5. Remove the capscrews from the adapter plate. The adapter plate capscrews are installed with Loctite, use a long handle wrench to them break loose. Lightly tap the back of the adapter plate with a rubber mallet to remove. (Figure 5-6)

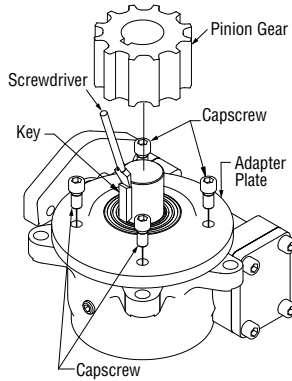

Figure 5-6, Adapter Plate Removal

6. The output shaft seals may now be serviced. (Figure 5-7)

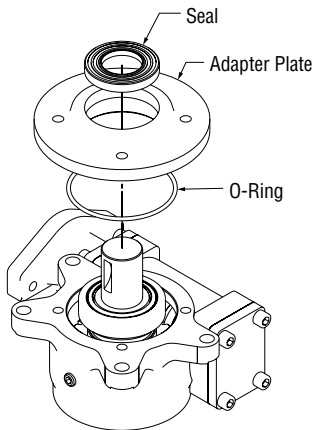

Figure 5-7, Output Shaft Seals

7. Remove the output shaft assembly. (Figure 5-8)

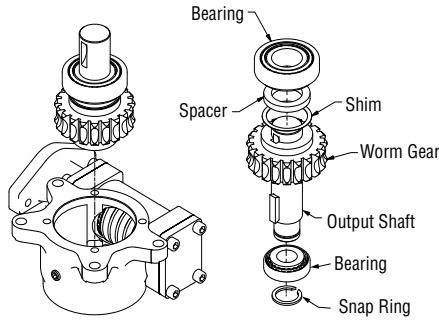

Figure 5-8, Output Shaft

8. The output shaft fits tightly, so you may need to remove the cap on the back of the gearbox and lightly tap the end of the output shaft with a rubber mallet to remove it. (Figure 5-9)

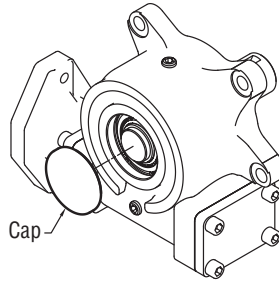

Figure 5-9, Output Shaft Cap

9. Remove the end cap and motor adapter. Make note of any installed shims. Capscrews are installed with Loctite, so use a long handle wrench to break them loose. (Figure 5-10)

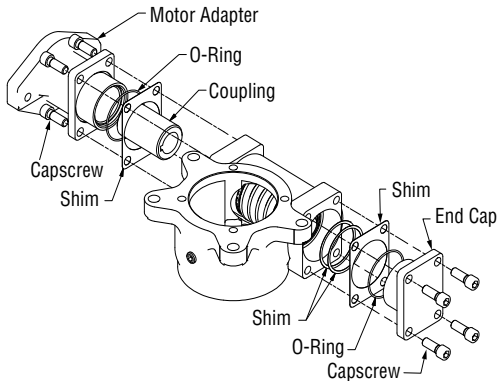

Figure 5-10, End Cap/Motor Adapter

10. Remove the input shaft assembly. The assembly fits tightly, so use a rubber mallet or press on the extended shaft to remove it. Remove the exposed key with a screwdriver, allowing the bearing and worm to slide off of the shaft. (Figure 5-11)

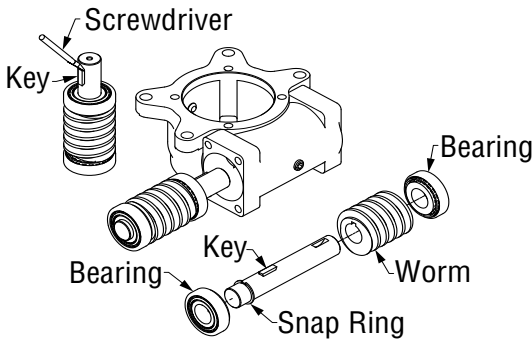

Figure 5-11, Input Shaft

5.4.3 Assembly for Part Numbers: YGC-29, YGC-32, YGC-43 and YGC-43-LH

1. Reassemble in reverse order. Use Loctite (Blue) on all capscrews. (See Section 6 for Torque Specifications)

Notice

It is important to get oil to the worm and worm bearings. Before reinstalling, dip the worm and worm bearings in oil for proper lubrication. (See Section 5.3)

5.5 Grease-Filled Gearboxes

5.5.1 Lubrication for Part Numbers YGC-48, YGC-49, YGC-49-LH, YGC-50 and YGC-50-LH

CAUTION

Load loss hazard.

Putting oil in this gearbox may result in loss of control, leading to equipment damage, damaged load or personal injury.

Use **ONLY** Mobilux EP1 grease to lubricate this gearbox. Do **NOT** use oil.

1. The grease in the gearbox will not need to be filled or changed unless the gearbox itself has been serviced.

2. If the gearbox has been serviced, remove the top and bottom plugs from the gearbox. Completely fill the gearbox with Mobilux EP1 or equivalent grease. (Figure 5-12)

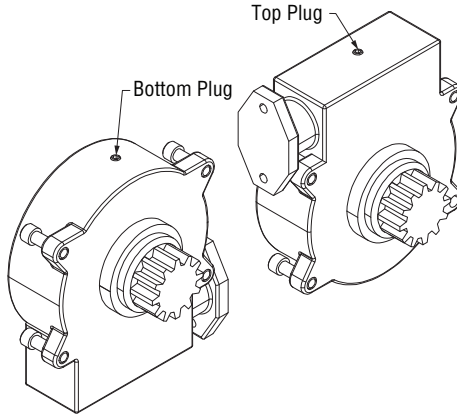

Figure 5-12, Gearbox Grease Plugs (YGC-49 shown)

3. Lay the gearbox with the pinion gear down and fill the gearbox from the top plug hole, allowing trapped air to escape through the bottom plug hole, and until grease shows in the bottom plug hole.
4. To fill a gearbox mounted to a back plate, follow the same procedure as above.
5. Reinstall the plugs.

5.5.2 Disassembly for Part Numbers YGC-48, YGC-49, YGC-49-LH, YGC-50 and YGC-50-LH

1. Remove the attachment from truck.
2. Before removing the gearbox from the back plate, place a support overhead or under the gearbox. Remove the mounting capscrews from the gearbox. (Figure 5-13)

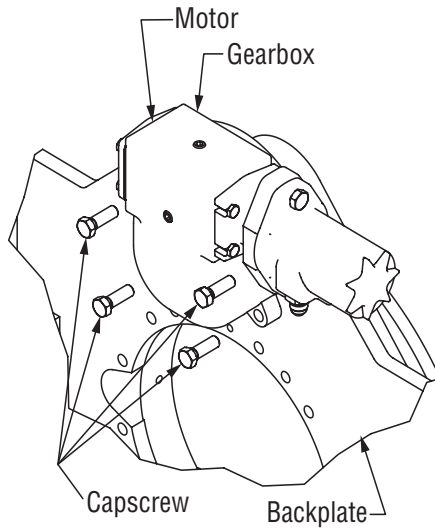

Figure 5-13, Gearbox Removal

3. Place the gearbox on a flat surface and remove the motor mounting capscrews. (Figure 5-14)

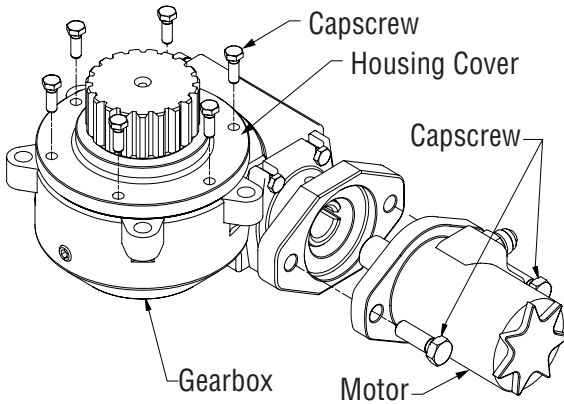

Figure 5-14, Motor/Housing cover Removal

4. Remove the capscrews from the housing cover. The housing cover capscrews are installed with Loctite, so use a long handle wrench to break them loose. Using a large screwdriver and hammer, separate the housing cover from the housing. (Figure 5-15)

Notice

Equipment damage hazard.

Impact wrenches could damage screws or sockets if screws have been secured with Loctite.

Use care when working with the gear assembly. Do not use an impact wrench on the screws that have been secured with Loctite.

Notice

Equipment damage hazard.

The equipment could fail if machined surfaces of the housing cover and housing are damaged during disassembly.

Use care when working with the gear assembly.

5. Remove the pinion shaft assembly. (Figure 5-15)
6. Remove the snap ring from the end of the pinion shaft. (Figure 5-15)

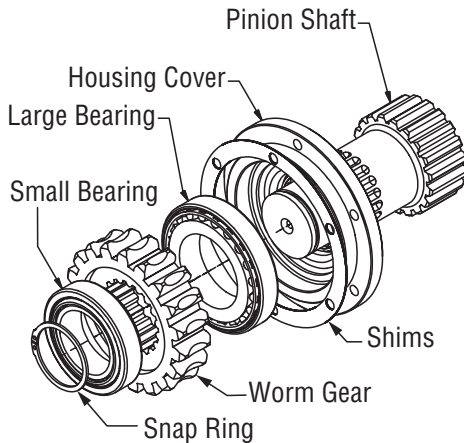

Figure 5-15, Pinion Shaft

7. Place the assembly in a press supporting the housing cover, **not the pinion shaft**. Press the pinion shaft through the small bearing and the worm gear. At this point the small bearing, worm gear and large bearing are loose and can be lifted out of the housing. (Figure 5-15)

Notice

Equipment damage hazard.

A chipped pinion shaft will affect machine performance.

Do not drop the pinion shaft onto a hard surface or it may chip.

Notice

The small bearing cup in the housing and the large bearing cup in the housing cover will need to be removed with a bearing puller.

8. Wipe as much grease out of the housing as possible with a rag and inspect for any foreign particles.
9. The oil seals may now be serviced. Note the orientation of the seals. (Figure 5-16)

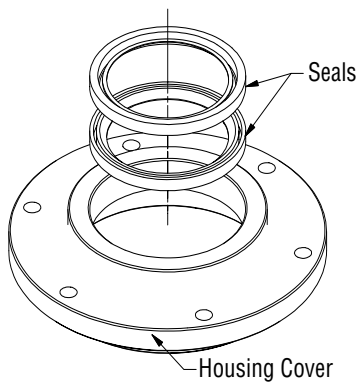

Figure 5-16, Pinion Shaft Seals

10. Remove the housing cover and motor adapter. Make note of any installed shims. Capscrews are installed with Loctite, so use a long-handled wrench to break them loose. Use a large screwdriver and hammer to separate the worm cap from the housing. Note any installed shims. (Figure 5-17)

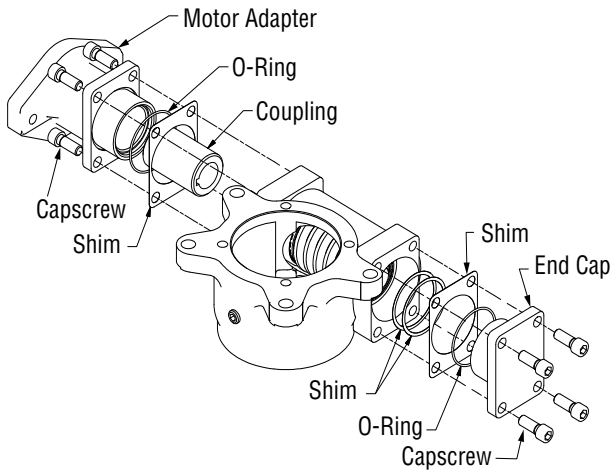

Figure 5-17, Worm Cap/Motor Adapter

Notice

Equipment damage hazard.

Damage to the housing cover or housing could reduce machine performance or void the warranty.

Do not damage the machined surfaces of the housing cover and housing.

11. The seal in the motor adapter can now be replaced. (Figure 5-18)

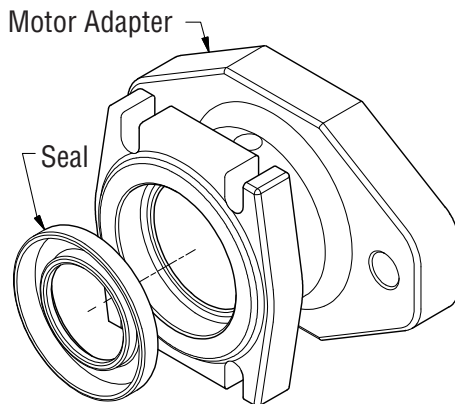

Figure 5-18, Motor Adapter Seal

12. Using a rubber mallet, lightly tap on the extended end of the worm gear shaft and remove it through the housing.

Notice

The bearing cup on the motor adapter side of the housing will need to be removed with a bearing puller.

13. Wipe as much grease out of the housing as possible with a rag and inspect for any foreign particles.

5.5.3 Assembly for Part Numbers YGC-48, YGC-49, YGC-49-LH, YGC-50 and YGC-50-LH

1. Install all seals. When replacing seals, use the following suggestions to ensure leak-free operation and long seal life.
2. Cover the keyway and any other surface breaks with smooth tape to protect the seal lip from being damaged.
3. Use a sealant between the OD of the seal and the ID of the bore into which the seal is installed. Make sure the seal bore is free of any burrs, nicks or scratches.
4. Be sure that the seal is not cocked in the seal bore. The outer face of the seal should be flush with the surface into which it is mounted.
5. Press on the bearing cup for the worm gear shaft into the housing on the worm cap side.
6. Install the worm cap and shims (if applicable).

Notice

Use Loctite (Blue) on all capscrews. (See Section 7 for Torque Specifications)

7. Place the bearing cones on both ends of the worm gear shaft and install into the housing.
8. Press on the bearing cup for the worm gear shaft into the housing on the motor adapter side.
9. Install the motor adapter and shims (if applicable).
10. Press on the small bearing cup for the pinion shaft into the housing.
11. Press on the large bearing cup for the pinion shaft into the housing cover.
12. Slide the housing cover onto the pinion shaft.
13. Slide on the large bearing cone onto the pinion shaft.
14. Press the gear onto the pinion shaft to the large bearing.

15. Slide on the small bearing cone onto the pinion shaft and secure with the snap ring.
16. Install the pinion shaft assembly and shims (if applicable). (Figure 5-19)

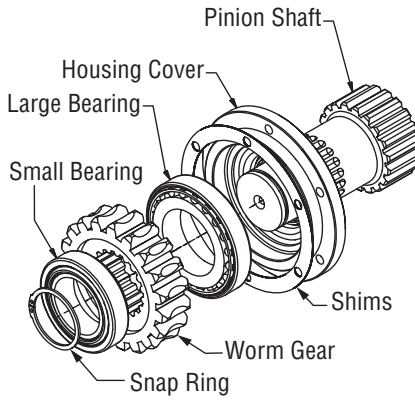

Figure 5-19, Pinion Shaft Assembly

17. Remove grease plugs and completely fill with grease. (See Section 5.5)

5.6 Motor Disassembly

If you are experiencing motor problems, start with replacing the shaft seal. If the motor needs further repairs, we recommend replacing it.

1. Remove the motor from gearbox. Clean the outside of the motor. Service the motor in a clean, dust-free work area. When clamping, use a protective device on the vise such as special soft jaws, pieces of hard rubber or board. (Figure 5-20)
2. Place the motor in a vice and clamp across the edge of the flange with output shaft up. (Figure 5-20) Do not clamp on the side of the housing.

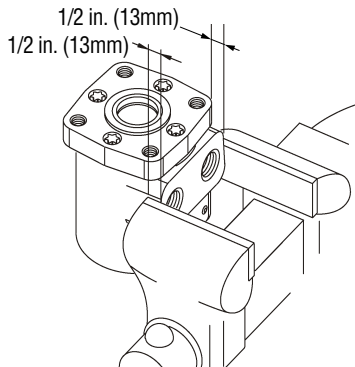

Figure 5-20, Motor Port Clamping

Notice

Equipment damage hazard.

Excessive clamping pressure on the side of the housing causes distortion.

Use caution when clamping the motor housing.

3. Remove capscrews from the mounting flange. These capscrews are installed with Loctite and will require 300-400 lb-in of torque to break loose and 100 lb-in of torque to remove. Do not use an impact wrench.

Notice

If more torque than given above is required to break capscrews loose, apply heat according to the following instructions.

Loctite partially melts when heated, reducing the torque required to remove the capscrew. Use a small-flame propane torch to heat a small area of the housing where the capscrew enters (Figure 5-21).

Be careful not to overheat the housing and damage the motor. Apply heat for 8 to 10 seconds while gradually applying torque to the capscrew with a socket wrench. As soon as the capscrew breaks loose, remove heat from the housing. Continue turning the capscrew until it is completely removed.

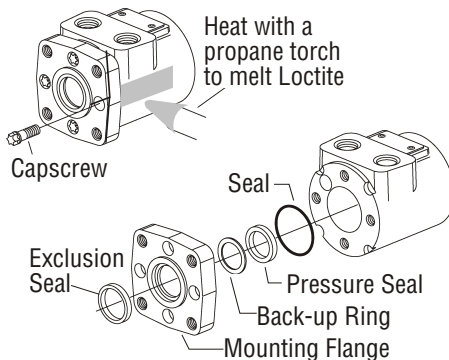

Figure 5-21, Capscrew Loctite

4. Remove the shaft key.
5. Mark the flange for proper orientation at reassembly.
6. Press down on the end of the shaft while lifting the flange (Figure 5-22). Do not disturb the shaft.

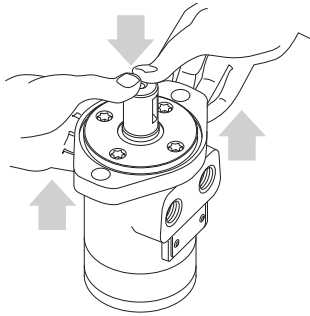

Figure 5-22, Motor Flange Removal

Notice

Some motors may have a quad seal and back-up ring in place of the pressure seal. The quad seal and back-up ring are no longer available and are replaced by the pressure seal. They are interchangeable, but some precautions must be taken to ensure proper installation. Follow the reassembly instructions. (Section 5.8)

7. The exclusion seal, back-up ring, pressure seal and seal will come off with the mounting flange (Figure 5-23).

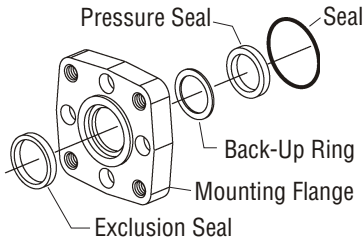

Figure 5-23, Mounting Flange Seals

8. Use a seal removal tool (Figure 5-24 and Figure 5-25) to remove the exclusion and pressure seals.

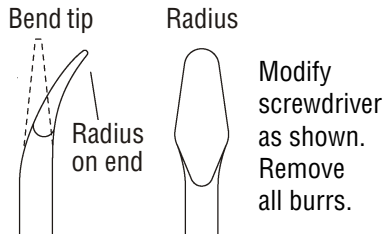

Figure 5-24, Seal Removal Tool

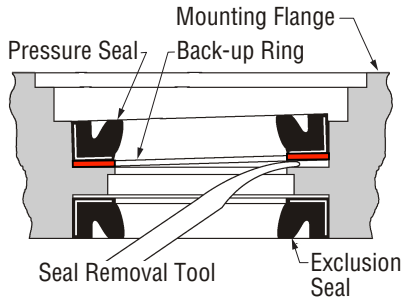

Figure 5-25, Seal Removal

Notice

Equipment damage hazard.

Any scratch on the surface of the seal cavity outer diameter could create a leak path.

Be careful not to scratch the seal cavity OD.

9. Work from the outer side for both (either) seals.
10. A metal plug, with seal, plugs a machining hole in the housing. It is not necessary to remove the plug and replace seal unless leakage occurs around the plug. To remove the plug, insert a 5 mm (.187 in.) hex key through the port opening and push it out. (Figure 5-26)

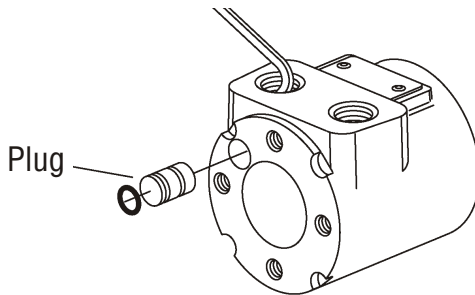

Figure 5-26, Housing Plug

5.7 Motor Assembly

1. Check all mating surfaces. Replace any parts with scratches or burrs that could cause leakage or damage. Clean all metal parts in clean solvent. Blow dry with air.

Notice

Equipment damage hazard.

Any scratch or foreign material on the surface of the seal cavity outer diameter could create a leak path.

Be careful not to scratch the seal cavity OD Use lint-free towels to wipe parts.

2. Check around the key slot and chamfered area of the shaft for burrs, nicks or sharp edges that could damage seals during reassembly. Remove nicks or burrs with a hard smooth stone (such as an Arkansas stone). Do not file or grind motor parts.

Notice

Lubricate all seals with petroleum jelly. Use new seals when reassembling motor. Refer to parts coverage.

Do not stretch seals before installing them.

Notice

Fully cured Loctite resists most solvents, oils, gasoline and kerosene, and is not affected by cleaning operations. It is not necessary to remove cured Loctite that is securely bonded in tapped holes; however, any loose particles of cured Loctite should be removed.

3. Wash the housing with solvent to remove oil, grease and debris. Pay particular attention to four tapped holes on the flange end.
4. Blow dry with compressed air. Clean and dry tapped holes.
5. Wire brush screw threads to remove cured Loctite and other debris. Discard any capscrews that have damaged threads or rounded heads.
6. Wash capscrews with non-petroleum base solvent. Blow dry with compressed air.
7. If you remove a plug or seal, lubricate new seal and install on plug. Some plugs have two O-ring grooves but require only one O-ring. Install O-ring in the groove closest to the end of the plug. Push the plug into the housing so the plug and housing are flush. Be careful not to damage the seal.
8. Lubricate the output shaft with hydraulic oil, then install the output shaft into the housing. (Figure 5-27)

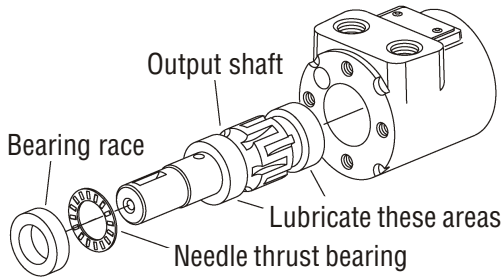

Figure 5-27, Output Shaft

Notice

Do not permit oil to get into the four tapped holes.

9. Install the needle thrust bearing, then the bearing race onto the output shaft. Pull the output shaft partially out of the housing. Push all three parts into the housing together (Figure 5-28). The bearing race must rotate freely when in position.

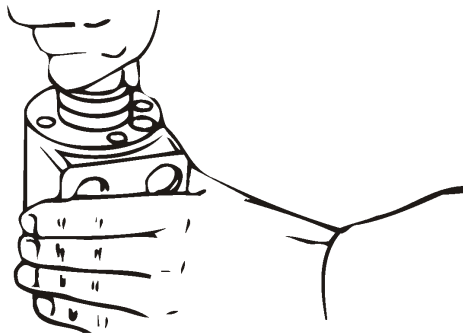

Figure 5-28, Output Shaft In Position

10. Install the exclusion seal into the mounting flange. Carefully press the exclusion seal into place. (Figure 5-29)

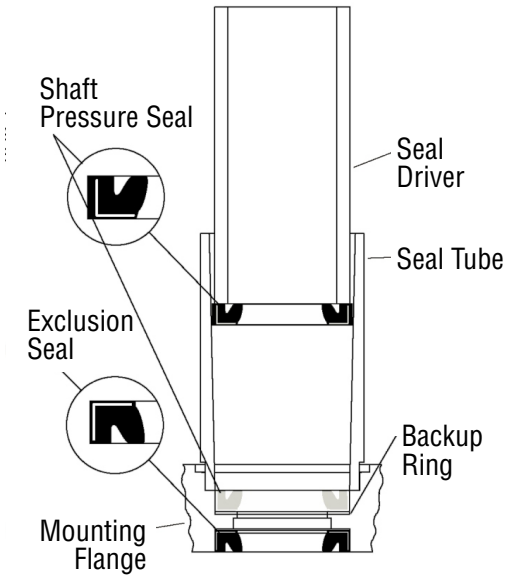

Figure 5-29, Seal Installation

11. Visually check the seal seat in the mounting flange for scratches or other marks that might damage the pressure seal. Check for cracks in the mounting flange that could cause leakage.
12. Lubricate the ID of the seal tube and OD of the shaft pressure seal with a light film of clean petroleum jelly. Align the small ID end of the seal tube with the seal seat in the mounting flange. Install the back-up ring and pressure seal in the tube with lips of the seal face up (Figure 5-29). Insert the seal driver in the tube and firmly push seal seat with a rotating action.

Notice

After installing the seal in the mounting flange, examine the seal condition. If damaged or improperly installed, you must replace it before continuing with reassembly.

13. Install the 49mm (1.937 in.) ID seal in the flange.
14. A light coat of Loctite Primer NF in tapped holes of housing is recommended. Allow primer to air dry for at least 1 minute. Do not force dry with air jet; the primer will blow away.

Notice

Primer is optional. With primer, Loctite curing time is approximately 15 minutes. Without primer, curing time is approximately 6 hours.

15. Apply 3 or 4 drops of Loctite sealant at the top of the threads for each of the four holes in the housing. Do not allow parts with Loctite applied to come in contact with any metal parts other than those for assembly. Wipe off excess Loctite from the housing face, using a non-petroleum base solvent.

Notice

Do not apply Loctite to threads more than 15 minutes before installing capscrews. If the housing stands for more than 15 minutes, repeat application. No additional cleaning or removal of previously applied Loctite is necessary.

16. Before installing the mounting flange and seal assembly over the shaft, place a protective sleeve or bullet over the shaft. Then lubricate the space between the exclusion seal and pressure seal, as well as the lips of both seals. (Figure 5-30)

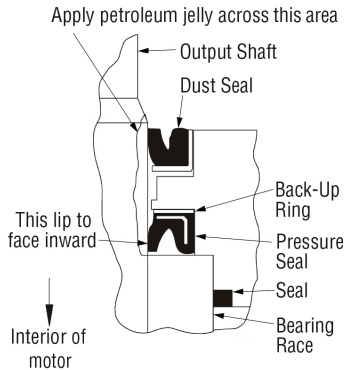

Figure 5-30, Output Shaft Lubrication

17. Install the mounting flange. Rotate the mounting flange slowly while pushing down over the shaft. Be careful not to invert or damage the seals.
18. After removing the protective sleeve, clamp the motor in a vise. Make sure the shaft cannot fall out. Install dry capscrews and alternately torque them immediately to 250 lb-in.

If you use a primer, allow to cure for 10 to 15 minutes. Without primer, allow 6 hours for curing time before subjecting the motor to high torque reversals. Otherwise, you can run the motor immediately. (Figure 5-31)

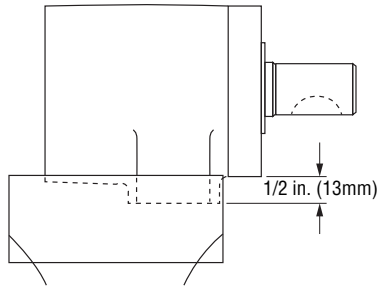

Figure 5-31, Motor Clamping

Notice

Make sure any new capscrews used are the correct length: 22 mm (.875 in.) under head length. See parts coverage for correct part number.

19. Reposition the motor with the gerotor end up, then clamp the motor across the ports.

Notice

To aid the installation of seals, apply a light coat of clean petroleum jelly to seals. Do not stretch the seals before installing them in groove.

20. Pour approximately 1.2 ounces (35 cc) of clean hydraulic oil into the output shaft cavity.
21. Install 73 mm (2.875 in.) ID seal into the housing seal groove. Avoid twisting the seal.
22. Install the drive. Use a felt-tip marker to mark one drive tooth. Align this tooth with the timing dot on the shaft.

Notice

If the drive is not symmetrical, install the larger splined end into the shaft.

23. Install the spacer plate.
24. Install 73 mm (2.875 in.) ID seal into the gerotor seal groove. Carefully place the gerotor onto the spacer plate, seal side toward the spacer plate.
25. For standard rotation align any star point with the marked tooth on the drive. (Figure 5-32)

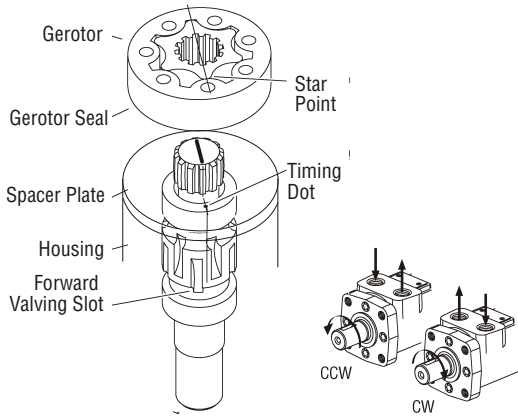

Figure 5-32, Standard Rotation

26. For reverse rotation align any star valley with the marked tooth on the drive. (Figure 5-33)

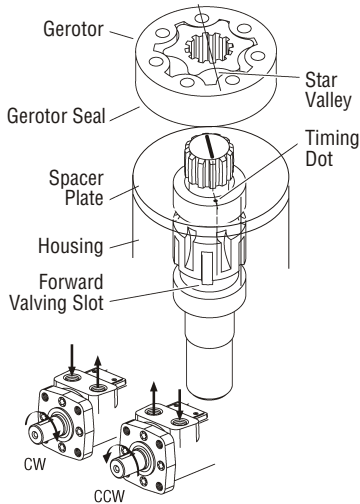

Figure 5-33, Reverse Rotation

27. Rotate the gerotor to line up the bolt holes. Be careful not to disengage the star from the drive or disturb the gerotor seal.
28. Install the drive spacer (if applicable).
29. Install 73 mm (2.875 in.) seal into the end cap. Carefully place the end cap on gerotor.
30. Install the capscrews and seal washers (if applicable) into the end cap. Pretighten the capscrews to 40 lb-in. Make sure the seal washers are properly seated. Then torque the capscrews to 235-250 lb-in.

5.8 Cylinder Removal

1. Fully extend the cylinder rod.
2. Turn off truck and disconnect the hydraulic connections.
3. Remove the pivot pin retainers and cylinder. (Figure 5-34)

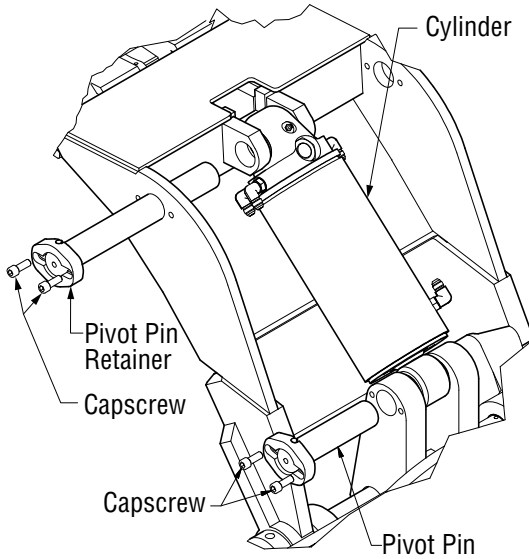

Figure 5-34, Pivot Pin Retainers

5.9 Cylinder Disassembly

1. Remove the cylinder from the attachment. See removal instructions, Section 5.8.

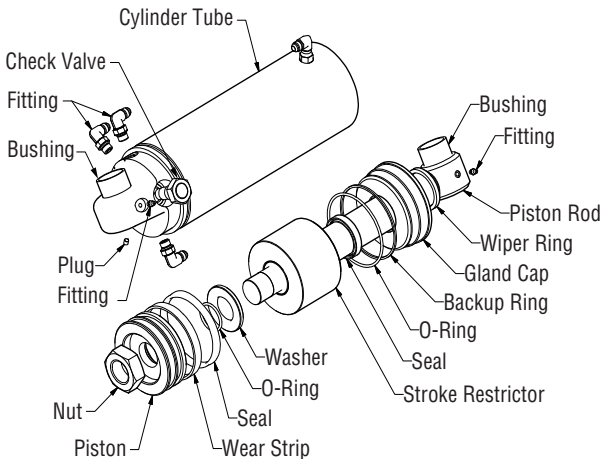

Figure 5-35, Cylinder Assembly

2. Clamp the cylinder lightly at the base end in a soft-jawed vise. Use a block or other support under the rod end of the cylinder. (Figure 5-36)

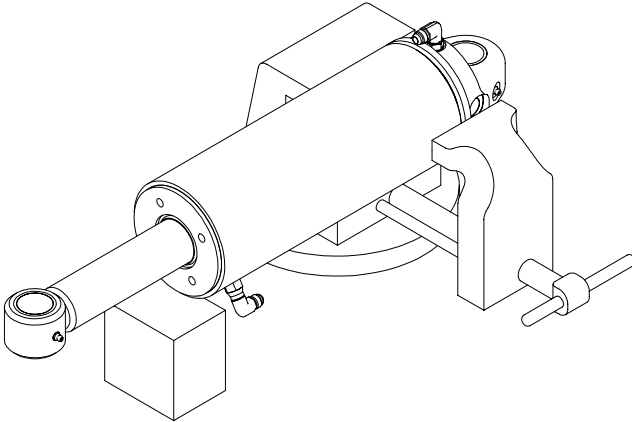

Figure 5-36, Cylinder Vise

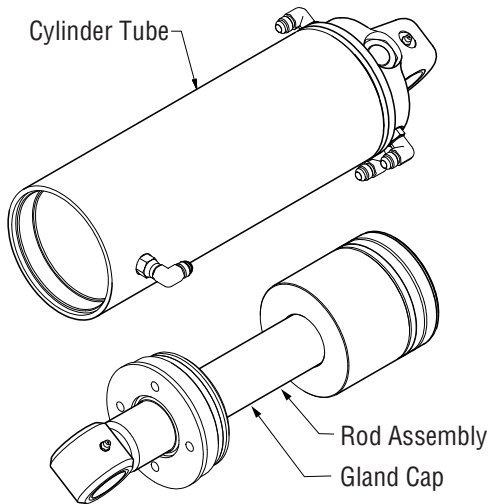

Figure 5-37, Rod Assembly

3. Remove the rod assembly from the cylinder tube.
4. Clamp the rod assembly in a soft-jawed vise on the wrench flats, not on the rod surface. If the rod does not have wrench flats, use two pieces of wood on both sides of the rod to prevent scarring. (Figure 5-38)

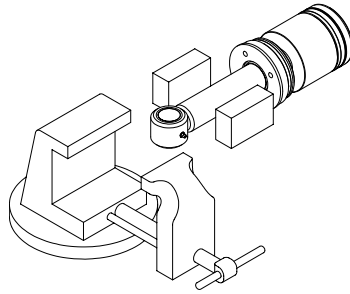

Figure 5-38, Piston Rod

5. Remove the piston retaining nut and remove the piston. (Figure 5-35)
6. Carefully pry up on the piston seals using a blunt tip screwdriver being careful not to scratch the seal grooves. Cut the seals to remove them from the piston. (Figure 5-39)

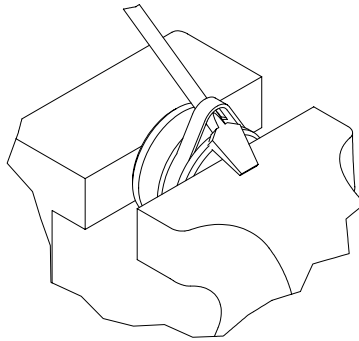

Figure 5-39, Seal Removal

7. Use the same procedure as above to remove the seals from the gland cap.

5.10 Cylinder Inspection

Inspect the cylinder tube bore for:

1. Deep scratches or nicks
2. Signs of galling or excessive wear
3. Out-of-roundness or deformities of the barrel

Inspect the piston for:

1. Scratches or nicks on the seal grooves
2. Wear on the OD

Inspect the cylinder rod for:

1. Scratches or nicks on the rod surface
2. Straightness of the rod
3. Damaged threads

Inspect the gland cap for:

1. Scratches or nicks in the seal grooves
2. Damaged threads or spanner wrench holes
3. Excessive wear in bore
4. Replace any component found to be defective.

5.11 Cylinder Assembly

1. Spray the piston, gland cap and seals with WD40 or other similar product to ease slipping of the seals in place.
2. Note the direction of the seal on the piston. Improper installation will result in poor performance. The cupped side or O-ring side of the seal should be facing the gland cap. (Figure 5-40)

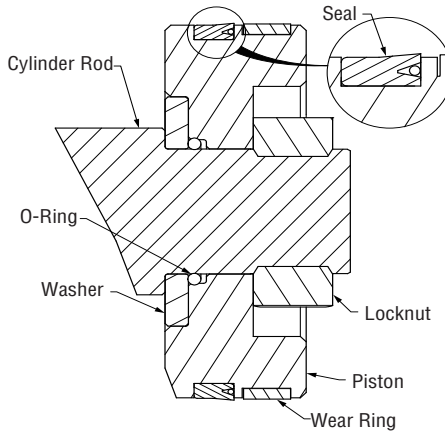

Figure 5-40, Piston Seal

3. Use a spanner wrench or similar tool to unscrew the gland cap from the cylinder tube.
4. Install the seals and wipers in the gland cap. Note the direction of the seals. The cupped side or O-ring side of the seal should be facing the piston. (Figure 5-41)

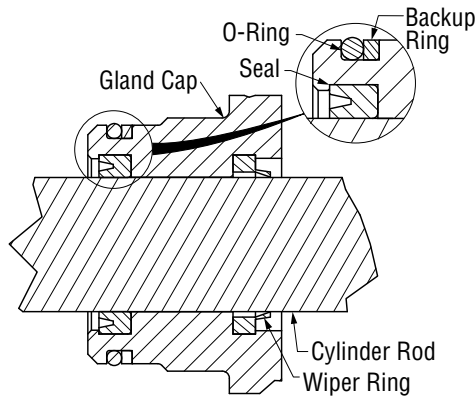

Figure 5-41, Gland Cap Seal

5. Install the piston on the rod and tighten the locknut to 70-75 ft-lbs.
6. Spray the inside of the cylinder tube with lubricant to ease inserting the rod and piston. Insert the rod and piston into the cylinder tube. Tap the rod in with a rubber mallet if resistance is encountered.
7. Install the gland cap on the cylinder rod being extremely careful not to cut the rod seal on the threads of the rod or rod shoulder. If available, use a sleeve or plastic electrical tape to cover the rod threads.
8. Tighten the gland cap using a spanner wrench.

5.12 Cylinder Installation

1. Install the pivot pin retainer to the cylinder base end.
2. Attach the hydraulic connections to the cylinder.
3. Line up the cylinder rod end to the body by extending the cylinder rod. Install the pivot pin retainer. (Figure 5-38)
4. Turn on the truck's power and activate the cylinders several times to bleed out trapped air.

Notice

Equipment damage hazard.

Equipment damage and loss of performance could result if air is trapped in the hydraulic system.

Activate the hydraulic functions several times after hydraulic service has been performed, to bleed trapped air out of the system before returning attachment to service.

5.13 Swivel Assembly Removal

1. Turn off the truck's power and activate the hydraulic functions in both directions several times to relieve the built up hydraulic pressure.



WARNING

Crush Hazard.

Serious injury could result if residual hydraulic pressure causes components to drift.

Cycle all hydraulic circuits as described above to relieve all system pressure.

2. Disconnect hydraulic hoses from the truck at the attachment's swivel assembly ports 1, 2, 3 and 4 (Figure 5-42). Cap hose ends with metal plugs and caps. Tag hoses for reassembly.
3. Disconnect the cylinder hydraulic hoses at the swivel assembly ports P1, P2, P3, P4, P5, P6, P7 and P8. Cap hose ends with metal plugs and caps. Tag for reassembly.
4. Disconnect the motor hydraulic hoses at the swivel assembly ports A and B. Cap hose ends with metal plugs and caps. Tag for reassembly.
5. Remove the swivel assembly mounting bolts and remove the swivel assembly.

5.14 Swivel Assembly Installation

1. Reinstall in the reverse order of removal (Section 5.13).
2. Turn on the truck's power and activate the hydraulic functions several times to bleed out trapped air.

5.14.1 Test Procedure

1. Check flow paths first, verify VA -> A, VB -> B, ETC

5.15 Stop Link Adjustment

Test stop link adjustment

1. Flex pad out.
2. Each pad has two stop link assemblies. Only one stop link on each pad is adjustable. Wiggle both stop links to assess how tight they are. Both stop links should feel snug, and allow for a small amount (1/16") of movement. Adjust the adjustable stop link as necessary to achieve equal tension on both links.

Adjust stop link

1. Remove cotter pin from clevis pin and remove clevis pin. (Figure 5-43)
2. Turn and remove stop link assembly from notch.
3. Loosen the nut three turns, then tighten or loosen the link.
4. Reinstall and test.
5. Repeat adjustment as necessary to equal the tension on the non-adjustable link.
6. When tension is acceptable, remove the adjustable stop link from the notch. Mark the correct link position by turning the nut up against the link.
7. Unscrew the link.
8. Apply Loctite 242 (Blue) to the threads and reinstall the link, just as far as the nut.
9. Tighten nut and link together.
10. Return stop link to notch. Reinstall clevis pin. Reinstall cotter pin/keeper.

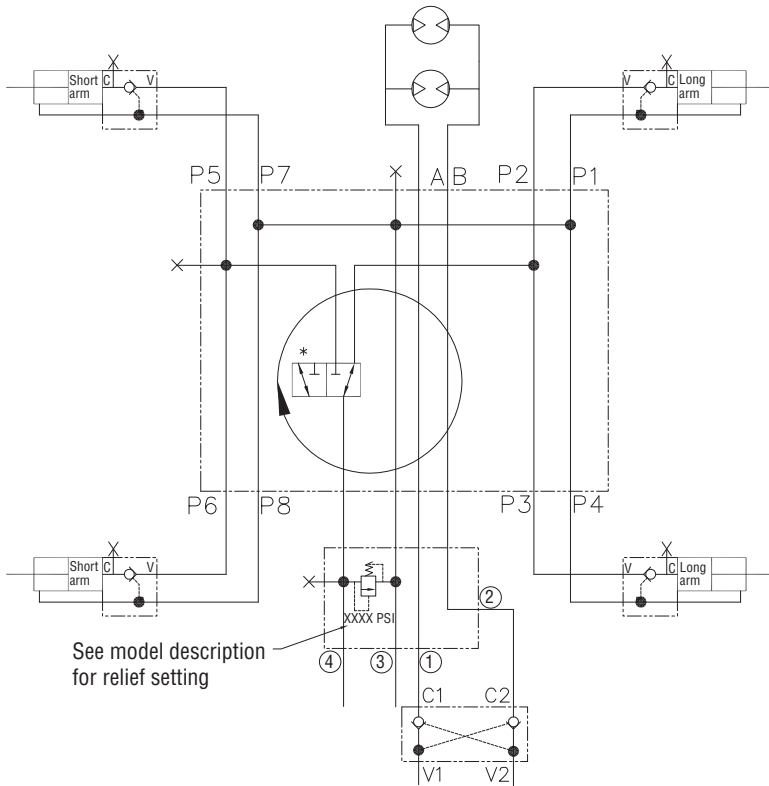

Figure 5-42, Hydraulics

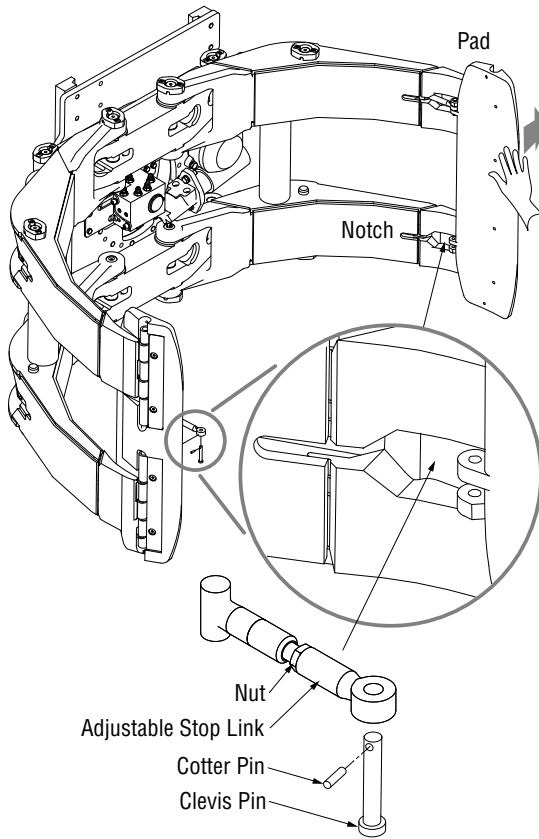

Figure 5-43, Stop Link Adjustment

5.16 Attachment Removal

1. Position the attachment arms to the width of the unit's body. Turn off lift truck. Relieve pressure in the hydraulic circuit to the attachment by cycling the lever back and forth several times.

! WARNING

Crush hazard.

Serious injury could result if residual hydraulic pressure causes equipment to drift during service procedures.

Cycle the hydraulic circuit as described above to relieve all system pressure.

2. Slightly raise the truck carriage to remove the bottom mounting hooks. If the attachment is equipped with quick hooks, simply press the slide plate release button and drop the slide plate down. (Figure 5-44)

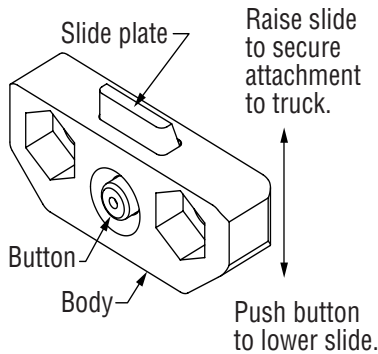

Figure 5-44, Quick hook

3. Position the attachment on the edge of a pallet. Lower the attachment so that the lower carriage bar misses the pallet when lowered. Tilt the mast forward to allow the carriage to disengage from the upper mounting hooks and back away. If lowering onto a floor, blocks of wood can be placed under the body of the attachment to raise the rear.
4. To reinstall, follow the installation procedure in this manual. See Section 4.2.



CAUTION

Equipment damage hazard.

Equipment damage and loss of performance could result if air is trapped in the hydraulic system.

Activate the hydraulic functions several times after hydraulic service has been performed, to bleed trapped air out of the system before returning attachment to service.

SECTION 6 MAINTENANCE SCHEDULE

6.1 Schedule

Daily Maintenance:

The attachment can stay mounted on the truck for all daily maintenance.

1. Check level of hydraulic oil in the truck reservoir and add oil if necessary.
2. Visually inspect all hoses and fittings for signs of hydraulic leaks.
3. Visually inspect for external damage or cracks.
4. Inspect lower hooks for proper clearance. Maximum clearance is 3/32 of an inch.
5. If the attachment is equipped with quick hooks check the slide plate latch for engagement.

Weekly 40 Hour Maintenance:

1. Complete the above daily checks.
2. Inspect all hoses and fittings for wear or damage. Inspect for hydraulic leaks.
3. Check for loose or missing bolts.

100 Hour Maintenance:

1. Grease the ring gear bearing assembly. See Section 5.2.
2. Grease the pinion/ring gear. See Section 5.2.
3. Grease all pivot pins. See Figure 6-1.

500 Hour Maintenance:

1. Remove attachment from lift truck for this inspection and maintenance cycle. Inspect mounting hooks for cracks, wear and deflection. Remove attachment from service if any defect is found.

Notice

If welding is required to make a structural repair, consult Long Reach factory before proceeding.

2. Re-torque the ring gear bearing capscrews. See Figure 6-3 for torque values.

1,000 Hour or 6 Month Maintenance:

1. Remove attachment from lift truck for this inspection and maintenance cycle. Inspect mounting hooks for cracks, wear and deflection. If any defect is found remove attachment from service.

2,000 Hour or 12 Month Maintenance:

1. Replace oil in the gearbox, oil-filled gearboxes only (part numbers YGC-29, YGC-32, YGC-43, YGC-43-LH, YGC-50, and YGC-50-LH).

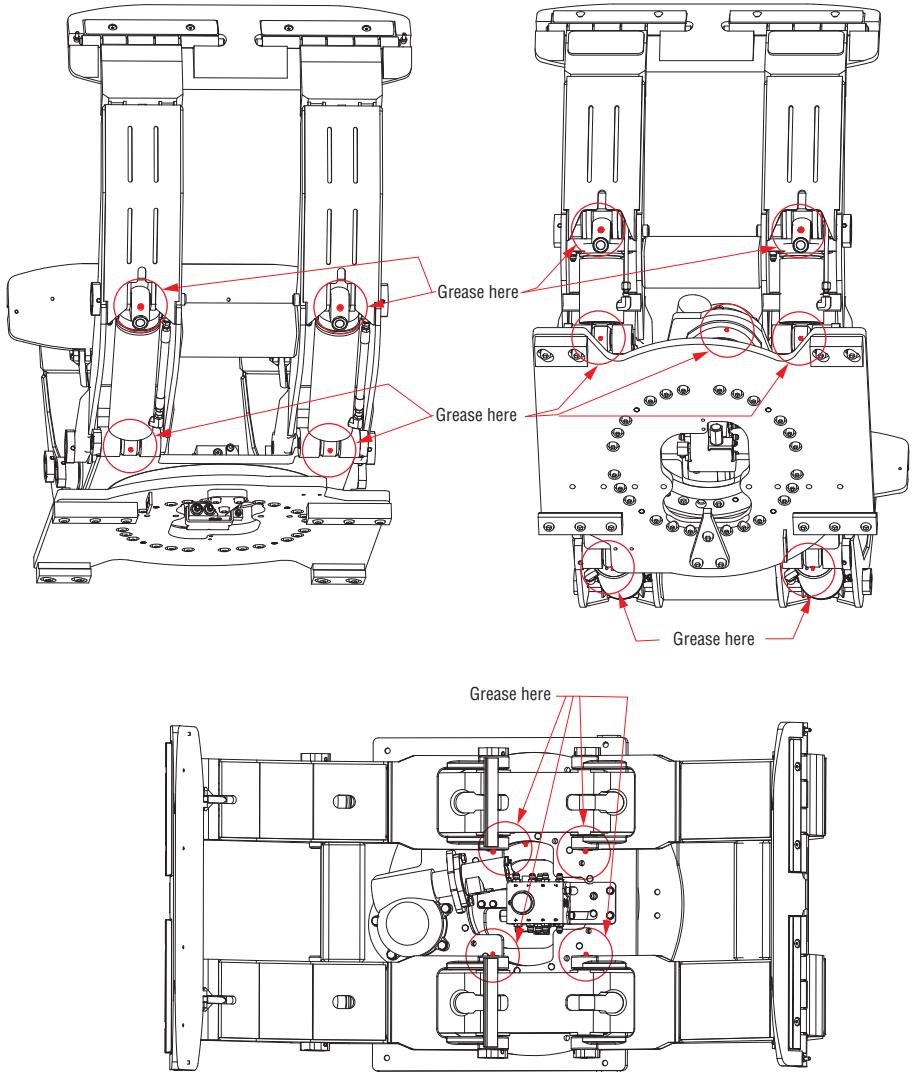

Figure 6-1, Grease Zerk Locations

6.2 Torque Specifications

The following torque values are to be used on all fasteners unless otherwise specified.

Lubricated refers to fasteners in the “As Received” condition, which is normally a light preservative oil coating on unplated fasteners and no oil coating on plated fasteners. No special steps are taken to add further lubrication prior to assembly.

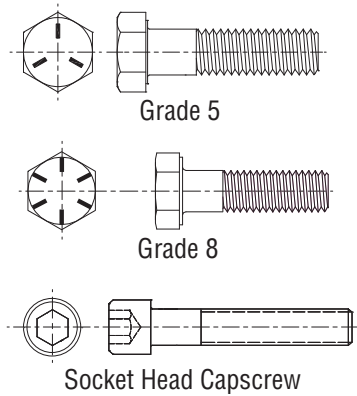

Figure 6-2, Bolt Identification

GRADE 8 COARSE THREAD		GRADE 5 COARSE THREAD		SOCKET HEAD COARSE THREAD	
Bolt Size	Lubricated Torque	Bolt Size	Lubricated Torque	Capscrew Size	Lubricated Torque
1/4"	11 ft-lbs	1/4"	7.5 ft-lbs	1/4"	12.5 ft-lbs
5/16"	23	5/16"	16	5/16"	26
3/8"	40	3/8"	28	3/8"	46
7/16"	63	7/16"	45	7/16"	74
1/2"	96	1/2"	68	1/2"	115
9/16"	140	9/16"	98	9/16"	160
5/8"	195	5/8"	140	5/8"	215
3/4"	340	3/4"	240	3/4"	385
7/8"	550	7/8"	390	7/8"	615
1"	820	1"	580	1"	920
1-1/8"	1,160	1-1/8"	715	1-1/8"	1,305
1-1/4"	1,640	1-1/4"	1,010	1-1/4"	1,840
1-3/8"	2,150	1-3/8"	1,330	1-3/8"	2,415
1-1/2"	2,850	1-1/2"	1,760	1-1/2"	3,205

Figure 6-3, Torque Specifications

THIS PAGE WAS INTENTIONALLY LEFT BLANK

Find the latest version of your
complete parts documentation in the
Manuals and Publications tab at
www.alliedsystems.com.

www.alliedsystems.com
21433 Oregon Street, Sherwood, OR 97140, USA
Phone: 800.285.7000 Fax: 800.231.3273