

# WE-5 Water Extractor

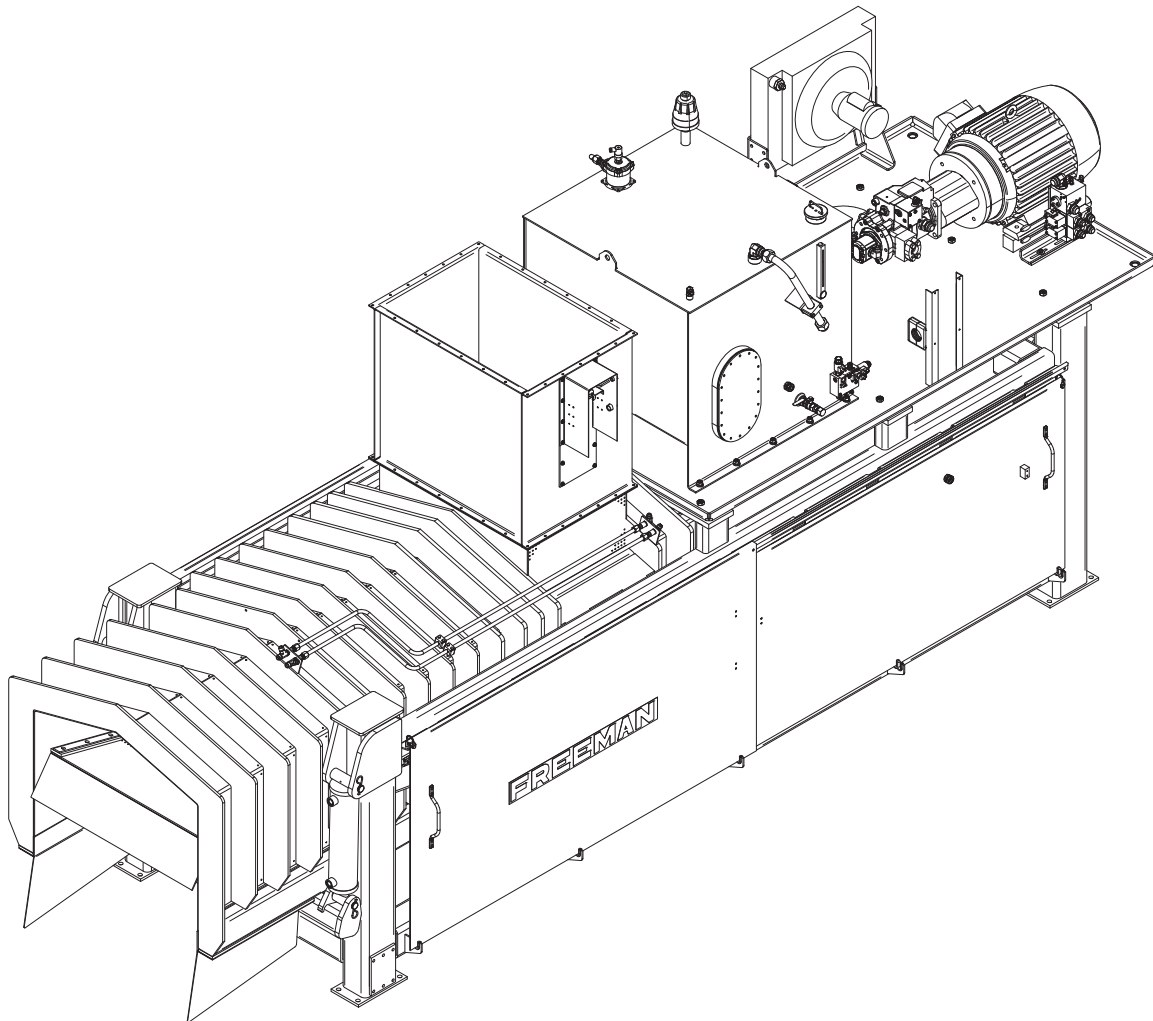

## Operator's Manual

## SAFETY PRECAUTIONS

**“THE BEST SAFETY DEVICE IS A CAREFUL OPERATOR”**

Always turn off system control and Lock-Out the electrical supply to the machine before inspecting, adjusting or servicing the machine.

Do not clean, lubricate, or make any adjustments on the equipment while it is in operation.

Do not start the equipment until you are certain everyone is clear of the machine and have ensured there are no tools on the unit.

Do not work around equipment in loose clothing.

Do not attempt to service any equipment while the motor is running.

Inspection Covers and Safety Shields should only be removed by authorized service personnel.

After servicing do not place the equipment back into operation until all Safety Shields and Devices have been replaced. Operation without Safety Shields and Devices can place the operator into a hazardous situation.

Do not open or work on the In-Feed System until the flow of material has been stopped and the Motor is off.

Do not make any adjustments or reach under any load bearing surfaces while loaded.

**INSTRUCT ALL OPERATORS ON SAFETY PRECAUTIONS.**



**WARNING: SOME ILLUSTRATIONS IN THIS MANUAL SHOW THE MACHINE WITHOUT SHIELDS TO ALLOW FOR A BETTER VIEW THE AREA BEING ADDRESSED. THE MACHINE SHOULD NEVER BE OPERATED WITH ANY OF THE SAFETY SHIELDS REMOVED.**

## SERIAL NUMBER LOCATION AND BALER IDENTIFICATION

Each Freeman Water Extractor is identified by means of a model number and serial number. As a further identification, all power units are provided with a serial number.

To ensure prompt, efficient service when ordering parts or requesting repairs, record the serial numbers in the spaces provided.

WE-5 SERIAL NUMBER \_\_\_\_\_  
Front side of main frame under motor.

POWER UNIT SERIAL NUMBER  
Electric Motor- \_\_\_\_\_

NOTE: The motor and pump end is considered the front of the Water Extractor.  
The sides are described as left-hand side and right-hand side as viewed from the rear while facing the chamber.

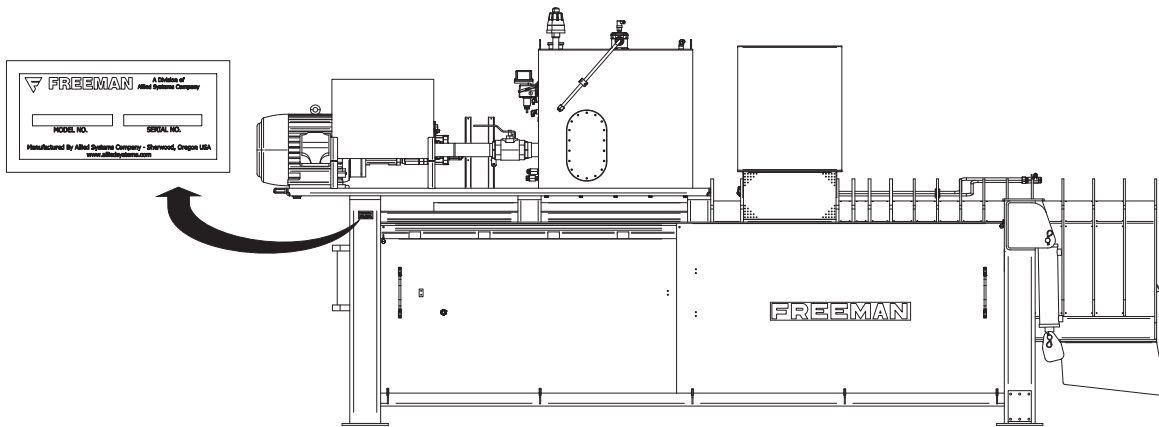

Starting with ASC-0WE5-503

## CONTENTS

<b>Adjustments</b> .....	<b>13</b>
Level Detector.....	14
Potentiometer .....	13
Water Throttling Valve.....	15
<b>Maintenance</b> .....	<b>15</b>
Factory Settings.....	15
Flushing .....	17
Maintenance Precautions .....	16
Oil Temperature .....	16
Procedure To Add Oil To The Reservoir.....	17
Procedure To Fill An Empty Reservoir .....	17
Pump And Motor Coupler .....	17
Reservoir Oil Level .....	16
Safety Precautions.....	16
To Change Oil And Clean A Contaminated Reservoir.....	17
Unplugging The Chamber.....	15
<b>Operation</b> .....	<b>10</b>
Auto Anti Plug .....	10
Automatic And Manual Operation .....	10
Operation Sequence.....	11-12
Plugging The Chamber.....	11
Starting The We-5.....	10
Turning Off Your We-5 .....	10
<b>Overview</b> .....	<b>1</b>
Dimensions / Weight.....	2
Drawing's and Schematics .....	1
Lubrication .....	2

<b>Power Unit</b> .....	<b>5</b>
Check Oil Level.....	5
Control Box.....	8
Directional Control Valve .....	7
Dual Oil Temperature Switches .....	6
Filter And Lubrication .....	5
Hydraulic Pump Controls.....	7
Oil Cooler / Oil To Water Heat Exchanger .....	6
Oil Level Float Switch .....	5
Oil Types.....	5
Proportional Valve Manifold.....	7
 <b>Restriction System</b> .....	 <b>9</b>
 <b>Setup</b> .....	 <b>3</b>
Check Motor Rotation .....	3
Connect Air Line To Air Nozzle On In-Feed Chute.....	5
Connect Water Lines To Water Throttling Valve (If Equipped).....	4
Electrical Connection.....	3
Emergency Motor Stop And Low Oil Shutdown.....	3
Mechanical Installation .....	3
Prime Pump.....	4
Remove Metal Shipping Bracket On Float Level Switch .....	4
 <b>Troubleshooting</b> .....	 <b>19</b>
DVC-10.....	19-20
Filter .....	23-24
Gauges .....	25
Machine Function .....	26
Pump .....	21-22

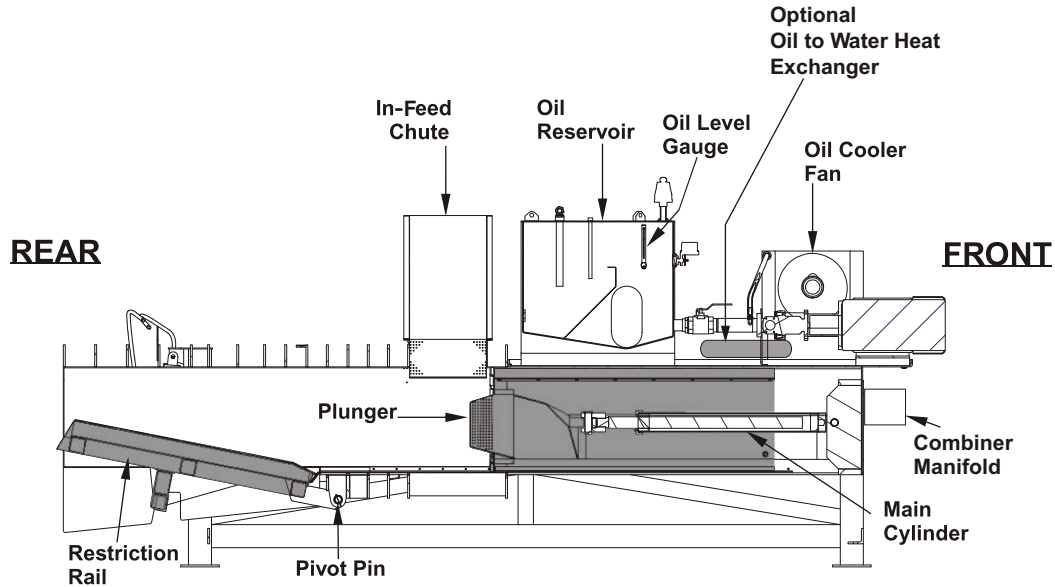

Figure 1. Right Side

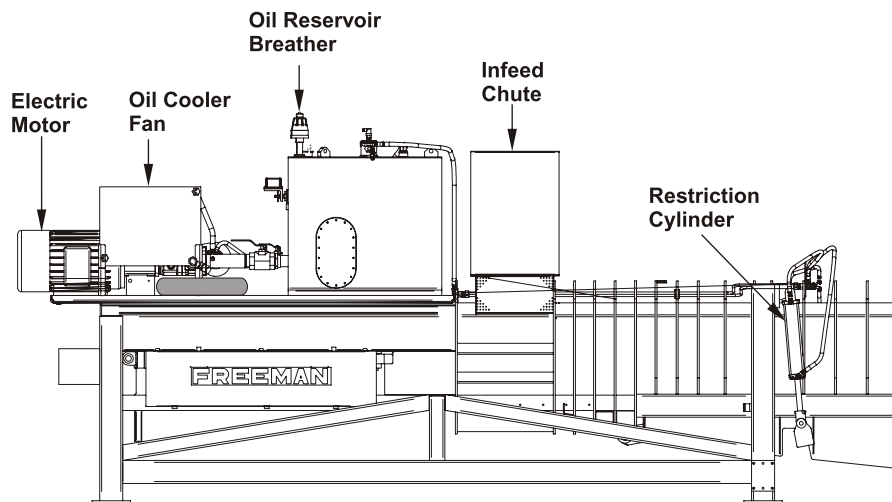

Figure 2. Left Side

## Introduction

**Automated water extraction** The Freeman Water Extractor is an efficient, automated tool for extracting water from a continuously or intermittently fed product. Product transport is eased with compaction and water removal. A wide variety of adjustments provide a machine to suit most products.

The plunger forces water from the product. A restriction system is activated only when the plunger is advancing. A control box switch allows the restriction rail control system to be bypassed so that pressure is applied continuously for setting pressures, testing, and troubleshooting.

### Dimensions / Weight

Length:.....20'  
 Height: .....9' 9"  
 Width: .....6'  
 Weight: .....Approximately 19000 Lbs With Oil

Restriction Rail To Ground Fully Open: ..... 9"  
 Motor: .....75 hp/230 or 460 Volt

Chamber Width.....40"  
 Chamber Height .....33"  
 Plunger Stroke Length.....42"  
 In-Feed Opening: .....24" x 36"

Volume... 7800 Cubic Feet Per Hour at 8 Strokes Per Minute.

### Lubrication

Hydraulic Oil: Mobil 424 or Mobil DTE 15M or equivalent to a Viscosity greater than 10 centistokes at 180°F and less than 200 centistokes at 60°F.

Hydraulic Reservoir Capacity: ..... 195 Gallon  
 Check Oil level:.....Daily  
 Change Return Line Filter: .....Every 6 Months  
 Test Oil:.....Every 4 months and change accordingly  
 Change Oil:..... \*Annually if oil isn't being tested  
 Change Breather Filter: .....Every 6 Months  
 Grease Electric Motor:..... See Manufactures Manual  
 Grease Restriction Cylinder Ends: .....Every 2 Weeks

\* Contact Freeman Service Department for recommendations on oil testing kits.

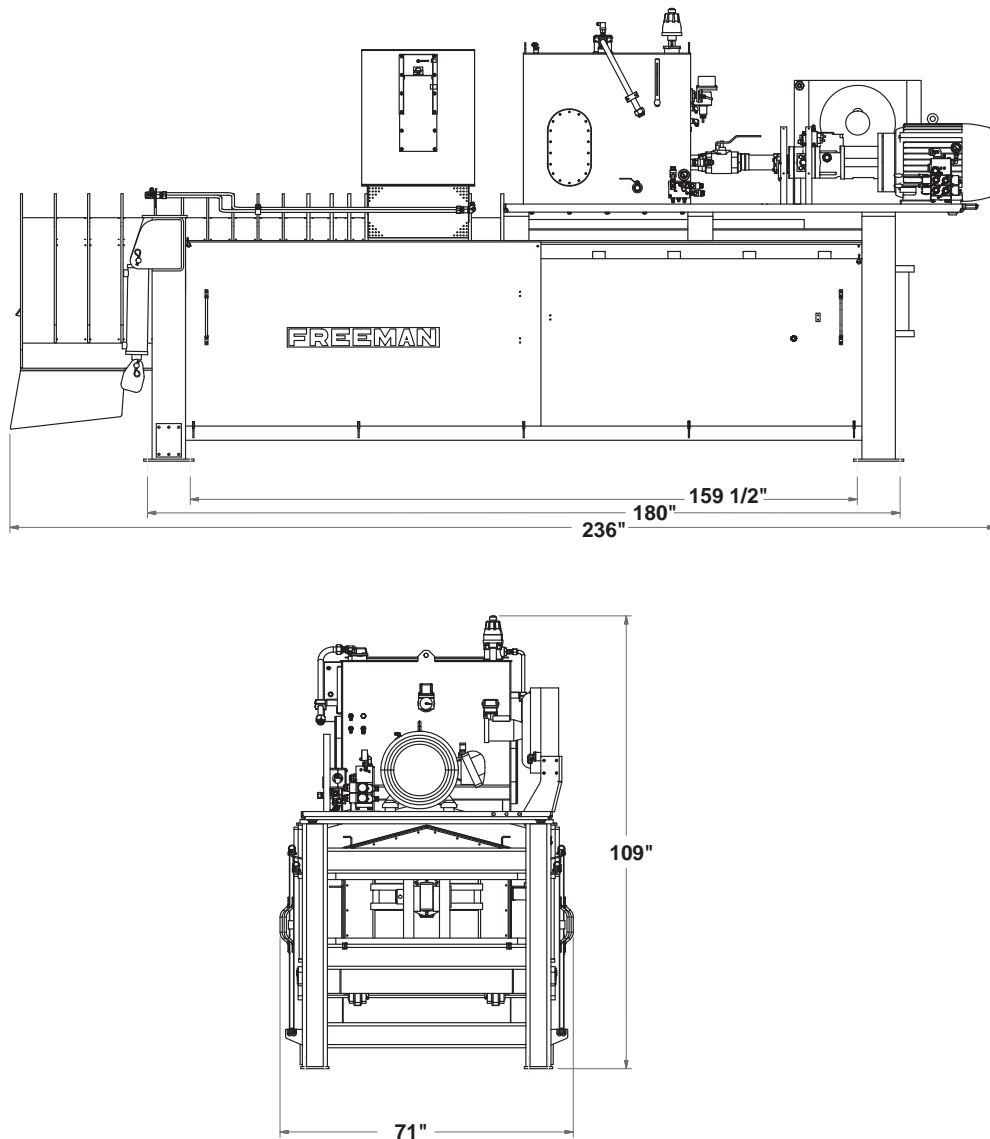

Figure 3. Dimensions



**CAUTION: ALWAYS TURN OFF SYSTEM CONTROL AND LOCKOUT THE ELECTRICAL SUPPLY TO THE MACHINE BEFORE INSPECTING, ADJUSTING OR SERVICING THE MACHINE.**

## Mechanical Installation

**Anchor the base** The water extractor location should allow efficient joining to the In-Feed chute, and provide personal safety. Provide adequate space for servicing. Locate the discharge so the product discharge falls free, with no backup of the product.

The water extractor should be located within a catchment to provide for water retention and water spray drainage. Use sixteen 3/4 inch bolts through the foot pads to anchor the water extractor to a foundation of concrete or steel. Use shims to provide a level surface.

## Electrical Connection

**Power unit connection** The 75 horsepower motor operates at 460 volts. At 460 volts, the rating is 86.5 amperes at full load, requiring 6 gauge copper wire for short wire runs. Supply wires should be correctly sized to prevent the motor from stalling during machine operation and momentary overloads. See wiring diagram 903057.

## Check Motor Rotation

**IMPORTANT:** Open up suction valves (see Figure 6 page 4) so the hydraulic pump is flooded with oil before turning on the motor (see Prime Pump section page 4).

Move the SYSTEM CNTRL Switch to STOP, RESTRICTION Switch to AUTO, and ANTI-PLUG switch to AUTO (see Figure 4). Remove the motor-pump coupler cover at the right side for viewing. Jog the motor to check for correct rotation. Note the motor shaft direction of rotation (standing at the front of the WE-5 viewing the motor). Correct rotation is clockwise (see Figure 5). Replace the cover.

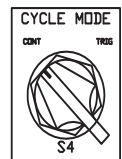
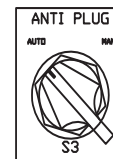
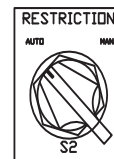
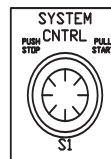
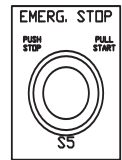
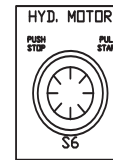
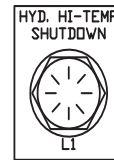
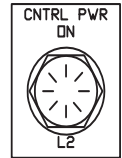
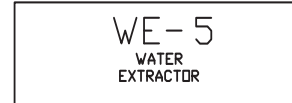

Figure 4 - Control Panel

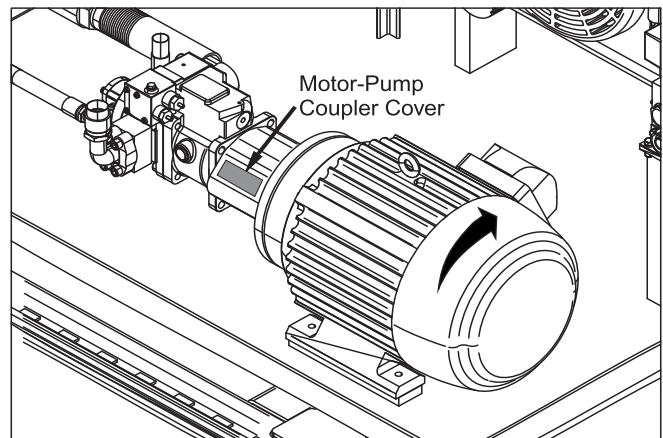

Figure 5 - Correct motor rotation

Motor power must be supplied through an external motor branch circuit disconnect and magnetic starter, incorporating a motor overload disconnect device. The motor branch circuit disconnect should have excess current prevention devices meeting the National Electric Code Table 430-152. Overload disconnects should be set to the motors full load current rating.

**Emergency motor stop and low oil shutdown** The emergency motor stop switch and low oil shutdown float switch (see Figure 13 page 6) are connected to control box terminals 15 and 16 (see wiring diagram 903057). Connect the motor starter power as shown on 903057 to place the switches in series with the motor control circuit.



## Prime Pump

**CAUTION: Do not let motor run continuously before the pumps are primed.**

1. Make sure the pump case is filled with clean, filtered fluid identical to that used in the rest of the system (see Filter and Lubrication page 5). The pump case must be full at all times to ensure proper lubrication of internal components.
2. Verify that piping is completed and any inlet valves are open to prevent cavitation or aeration of the pump.
3. Confirm that the direction of rotation of the motor matches the pump installed ( see Check Motor Rotation page 3).
4. Jog start the motor with the pump unloaded and operate until the air is bled from the system.
5. Check the pump for external leakage, abnormal noise, and vibration.

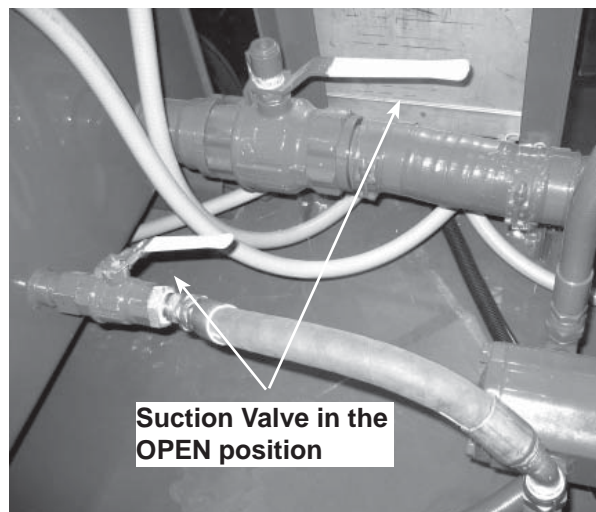

Figure 6 - Suction Valve

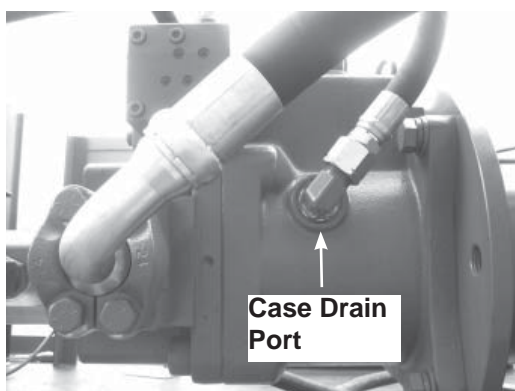

Figure 7 - Prime Pump Location

## Connect Water Lines To Water Throttling Valve (if equipped)

A Water Throttling Valve is used with water extractors that are equipped with an Oil to Water Heat Exchanger. The throttling valve meters the flow of cooling water through the heat exchanger based on the temperature of the hydraulic oil. The valve is set to open when the oil temperature reaches 110°F. Connect in-going water line (maximum 25 GPM) to Water In port . Connect out-going water line to Water Out port (see Figure 8).

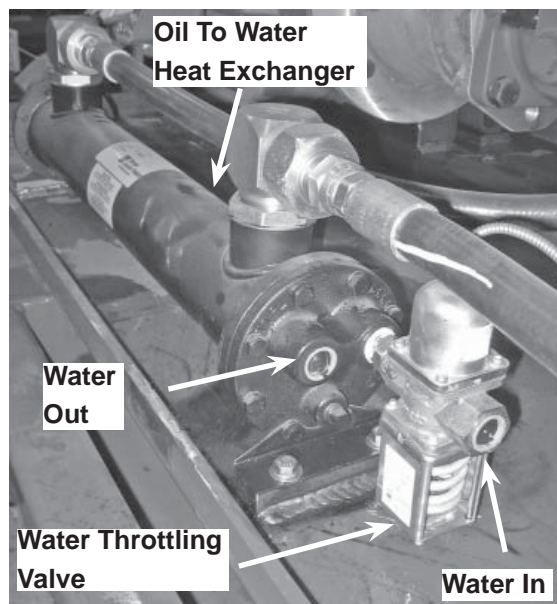

Figure 8 - Water Throttling Valve

## Remove Metal Shipping Bracket on Float Level Switch

A metal bracket is installed on the Float Level Switch located on the Oil Reservoir (see Oil Level Float Switch page 5) to prevent damage to the float during transport. Remove the bracket (see Figure 9).

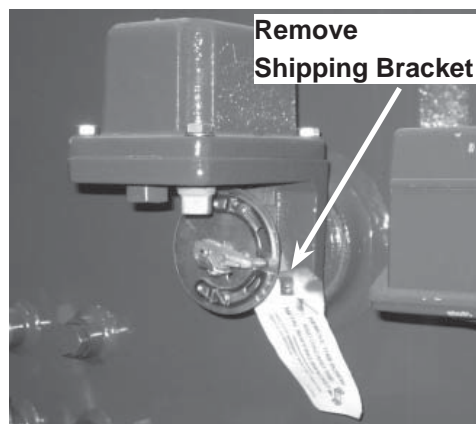

Figure 9 - Water Throttling Valve

## Setup / Power Unit

### **Connect Air Line to Air Nozzle On In-Feed Chute**

The Air Nozzle cleans the Plexiglas in front of Level Detector. This keeps the Level Detector accurate.

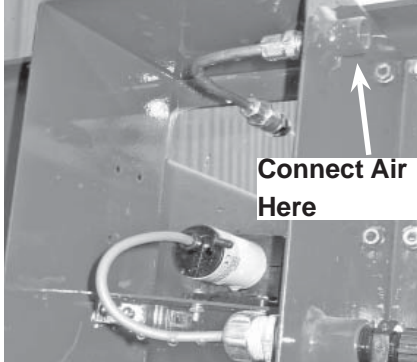

Figure 10 - Air Nozzle

### **Hydraulic Power Unit**

**Check oil level** Check the oil level gauge, which should be 1" to 2" below the HIGH mark with all 3 cylinders retracted and 2" to 3" below the High mark with all three cylinders extended (see Figure 12 and Figure 36 page 16).

**Filter and lubrication** Dirt is an intolerable element in a hydraulic system. Your power unit is designed to preclude the introduction of external dirt into the system.

All new oil put into the system is added through a "Fill Port" (see Figure 11). To get from the fill port into the system, the oil must pass through the Fill Screen. This degree of filtration helps to reduce component wear within the system, resulting in improved system life.

The oil tank breather cap should be changed yearly (see Figure 11).

Each time a new breather filter is installed please take the time to write the yearly replacement date on the unit with a black felt pen.

Reservoir capacity is 195 gallons. Oil change intervals vary according to actual operating conditions. Under normal conditions the oil should be changed every 4 months of operation.

#### **Use one of the following recommended oil types:**

Chevron AW 46 or Mobil DTE 25 (ISO 46) or equivalent. ISO grade 46 is required in some colder climates. (In such cases call Allied Systems for approval).

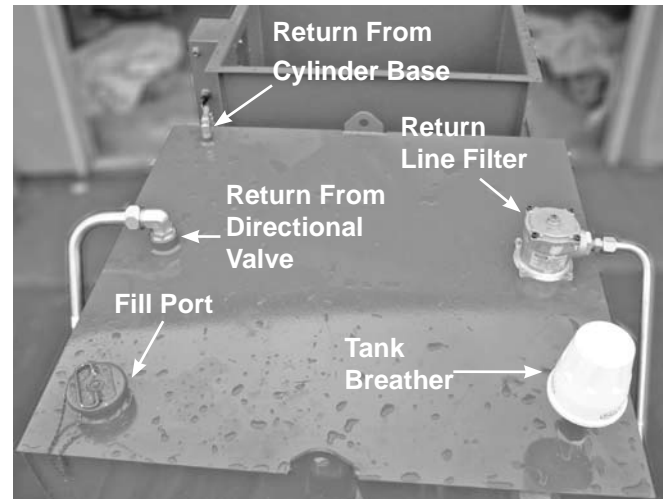

Figure 11 - Fill Port and Breather Cap

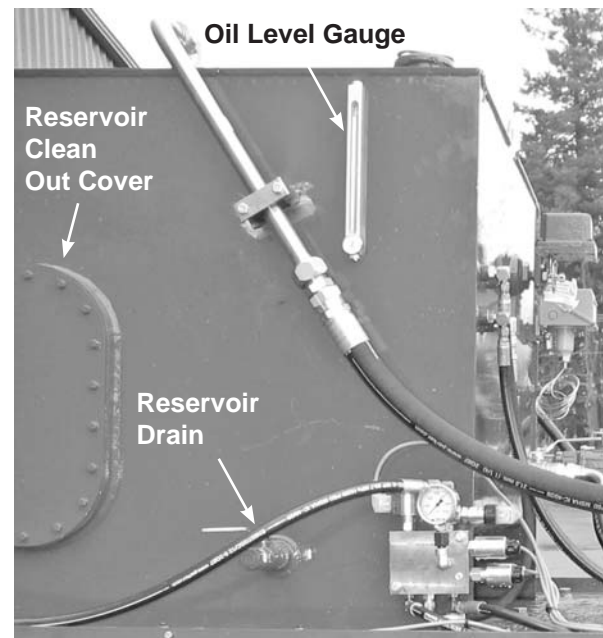

Figure 12 - Reservoir Drain

**Oil Level Float Switch** An emergency low level float switch (see Figure 13) is installed to automatically stop the pump to protect it from damage in the event of line breakage or faulty maintenance. The low level float switch is connected as shown on 903057 wiring diagram.

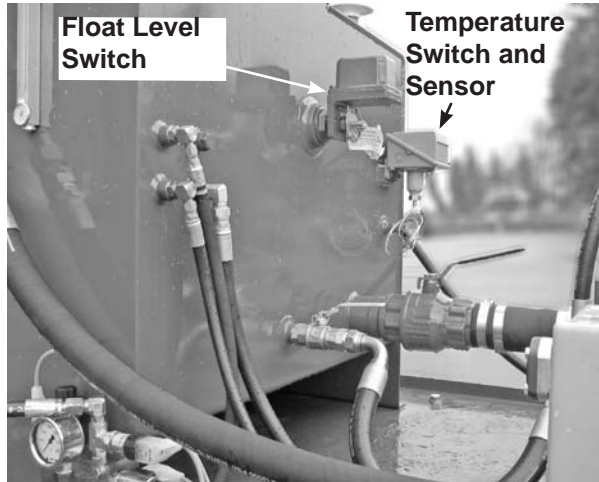

Figure 13 - Temperature and Float Level Switch

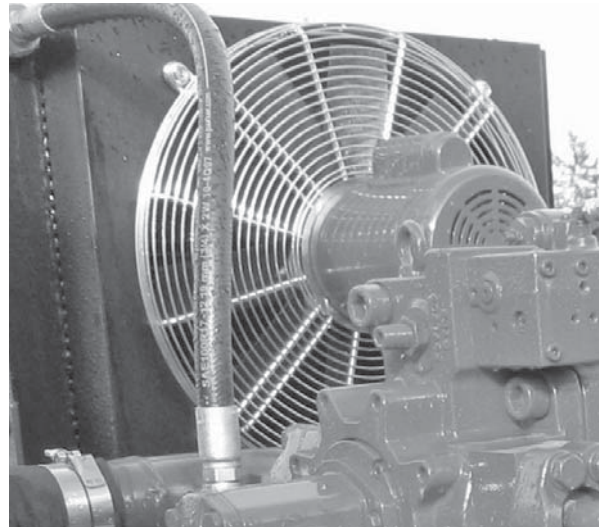

Figure 15 - Oil Cooler

**Dual Oil Temperature Switches** Installed in the WE-5 system to prevent damage caused by high temperatures. Temperature switch Dial #2 set at 120°F (see Figure 14) turns the cooler fan motor on and off (if equipped). Dial #1 set at 150° F stops the pump motor at the high setting. See wiring diagram 903057 and manufacturer’s manual in your document pack for settings. Dial #3 is not used.

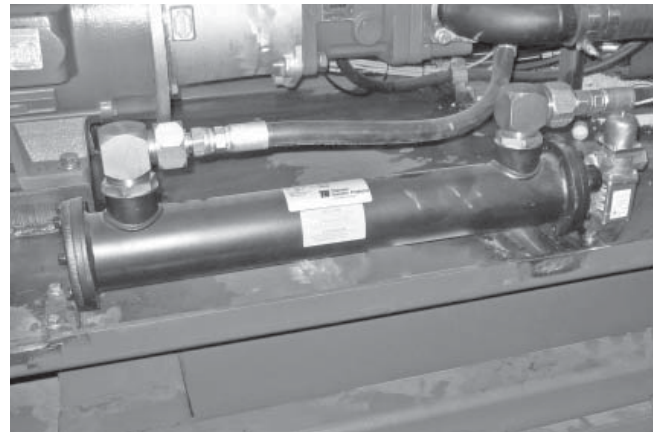

Figure 16 - Heat Exchanger

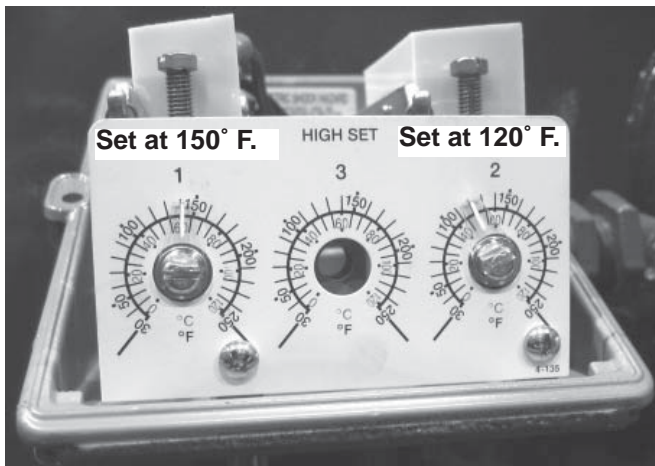

Figure 14 - Temperature Switch

**Oil Cooler / Oil To Water Heat Exchanger** The Hydraulic system operate’s more accurately when the oil viscosity is consistent. Since oil viscosity varies with temperature, your power unit is equipped with a Oil Cooler (see Figure 15) or Oil to Water Heat Exchanger (see Figure 16) to automatically maintain the oil temperature below 140°F.

The Oil Cooler uses the Temperature Switch sensor Shown in Figure 13. The Oil to Water Heat Exchanger uses the Sensing Bulb shown in Figure 17.

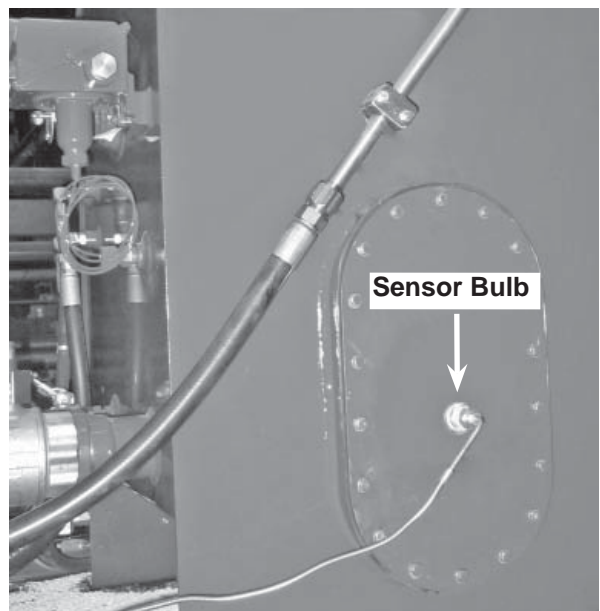

Figure 17 - Oil Temperature Sensor Bulb for Heat Exchanger

## Power Unit

**Directional Control Valve** is for adjusting the direction of the plunger in MANUAL operation (see Manual Operation page 10). The Main System Pressure gauge is located on the Directional Control Valve (see Figure 18).

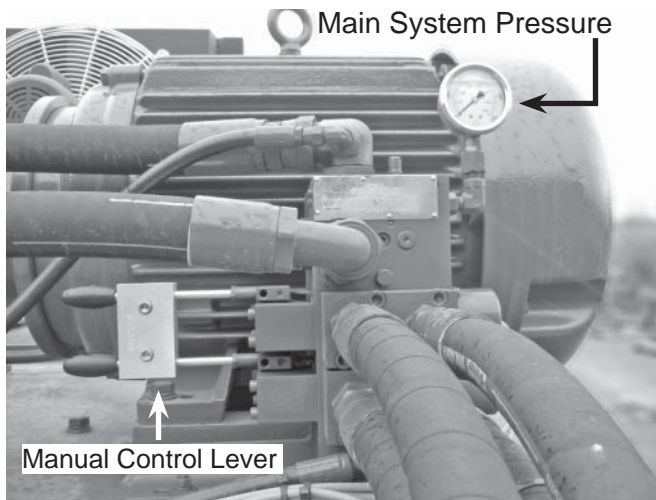

Figure 18 - Directional Valve

**Hydraulic Pump Controls** The hydraulic pump has 3 different adjustments (Cut off Pressure, Differential Pressure and Torque Limit) and is pre-adjusted at the factory. **DO NOT** make any adjustments unless directed by the factory. Readjustment without the approval of Allied Systems Co. voids the warranty.

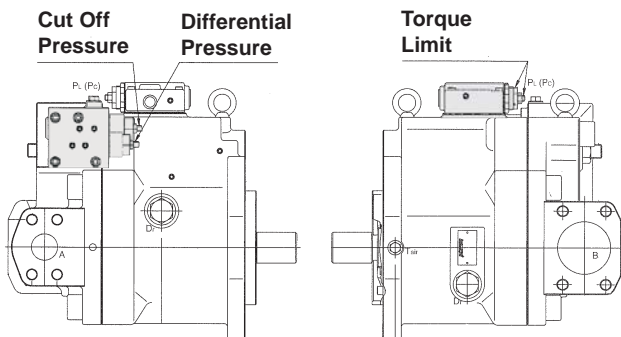

Figure 19 - Hydraulic Pump

**Proportional Valve Manifold** Consists of Restriction Pressure Gauge, Main Pressure Valve, Restriction Valve and Anti Plug Valve.

**System Proportional Valve** The Main Pressure Min-Max pot #2 (see Figure 30 page 13) located in the panel provides a control signal which varies the pressure output from the system proportional valve. When the pot is set at Min, the main system pressure will be at a minimum 150 psi. When the pot is set at Max, the main system pressure will be at a maximum value 3000 psi.

### Main System Pressure Limits

Minimum pressure: 150 psi

Maximum pressure: 3000 psi

**Restriction Proportional Valve** The Restriction Min-Max pot #3 (see Figure 30 page 13) located in the panel provides a control signal which varies the pressure output from the Restriction Proportional Valve. When the pot is set at Min, the pressure in the restriction rail system will be at a minimum 75 psi. When the pot is set at Max, the pressure in the restriction rail will be at a maximum value of 2500 psi or equal to system pressure. The restriction pressure will never exceed main system pressure.

### Restriction Pressure Limits

Minimum pressure: 75 psi

Maximum pressure 2500 psi

**Anti Plug Valve** is a 3-way, 2-position valve that is used to vent restriction pressure to the tank. Auto Anti Plug system starts if the plunger hasn't reached home position (full extension) within 4 seconds (see Auto Anti Plug page 10).

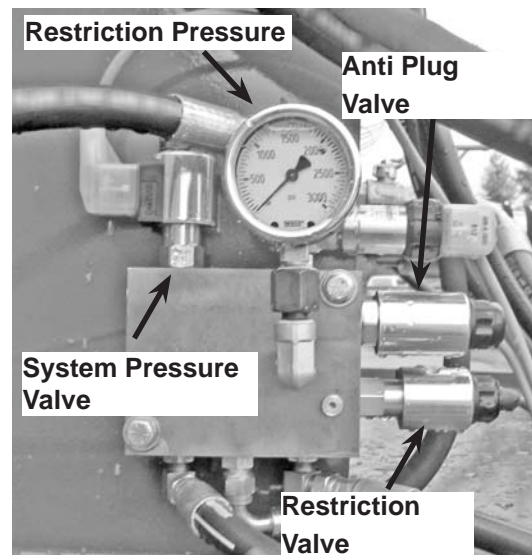
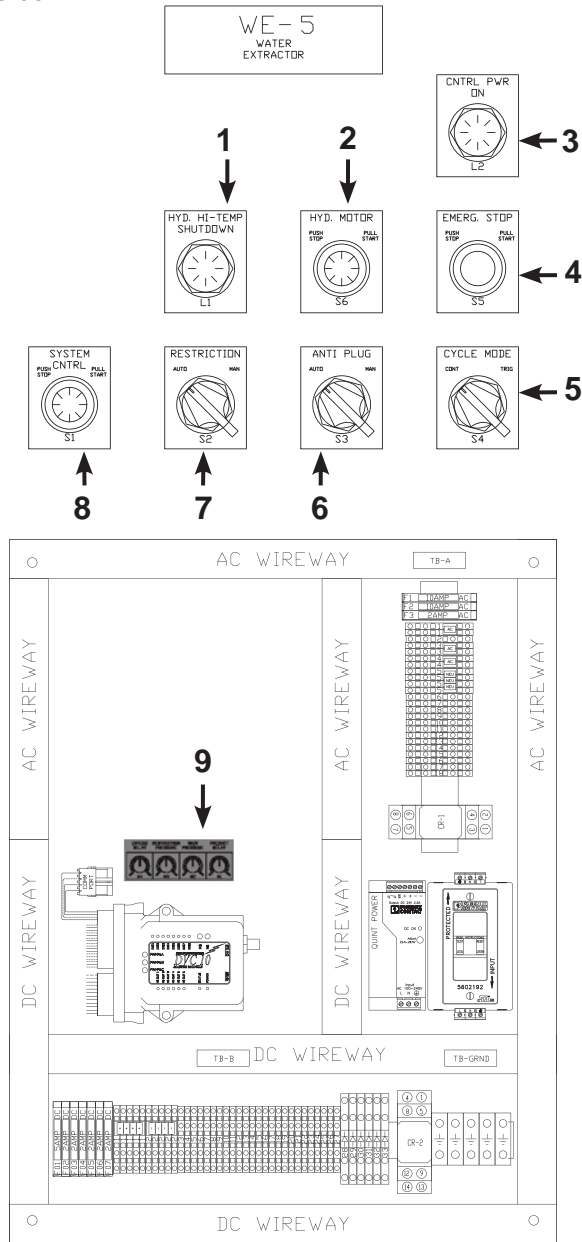

Figure 20 - Proportional Valve Manifold

## Control Box

The Control Box is used to control the WE-5. There are controls on the front panel as well as on the inside of the box.



**Figure 21 - Control Box**

1. **HYD HI-TEMP SHUTDOWN** (Hydraulic High Temperature Shutdown) Indicator Light illuminates when the high temperature switch activates (150° F) and the machine shuts down (see Dual Oil Temperature Switches page 6).

2. **HYD MOTOR** (Hydraulic Motor) Button (S-6) Turns the motor on and off. **START** and **STOP**. Make sure there is oil in the reservoir, suction valve in open position and pump is primed (see page 4) before turning on the motor.

3. **CNTRL PWR** (Control Power) Indicator light illuminates when the system is on. **CNTRL PWR** Light and **SYSTEM CNTRL** light need to be on for plunger to cycle.

4. **EMERG STOP** (Emergency Stop) Switch (S-4) Shuts down all power to the control panel when in **STOP** mode. **EMERG. STOP** button needs to be pulled in the **START** position to start the WE-5.

5. **CYCLE MODE** Switch (S-6) In **CONT** with the **SYSTEM CNTRL** switch in **START** the plunger will continuously cycle with option of delaying plunger extend and retract using the Potentiometers Pot #1 and pot #4 (see Potentiometer adjustments on page 13). The In-feed chute level detector is ignored. In **TRIG.** the machine will cycle the plunger when the level detector (**PROX 1**) on the in-feed chute is triggered (see Level Detector Adjustments on page 14).

6. **ANTI-PLUG** Switch (S-3) **AUTO** raises restriction rail. **MANUAL** Anti-Plug valve opens to allow restriction rail to gradually drop. Restriction pressure to 0. Use **MANUAL** mode when unplugging the chamber (see Unplugging Chamber section page 15).

7. **RESTRICTION PRESSURE** Switch (S-2) **AUTO** is the normal operating setting for the switch. **MANUAL** setting is only used to either set the system operating and restriction pressures or to allow for manual actuation of the plunger (via the directional valve) at system pressure when the System Control Switch is set to "STOP"

8. **SYSTEM CNTRL** (System Control) Switch (S-1) **START** loads the pump to pressure set by Pot 2 (**MAIN SYSTEM PRESSURE**). Plunger starts to cycle. **STOP** main system pressure will not exceed 150 psi. Restriction pressure will not exceed main system pressure. Plunger stops and can be controlled manually using the directional valve (see page 7).

9. **POTENTIOMETER** Located inside the control box. Adjustments for: pot #1 **EXTEND DELAY**, pot #2 **RESTRICTION PRESSURE**, pot #3 **MAIN PRESSURE**, pot #4 **PRODUCT DELAY** (see Potentiometer Adjustments page 13).

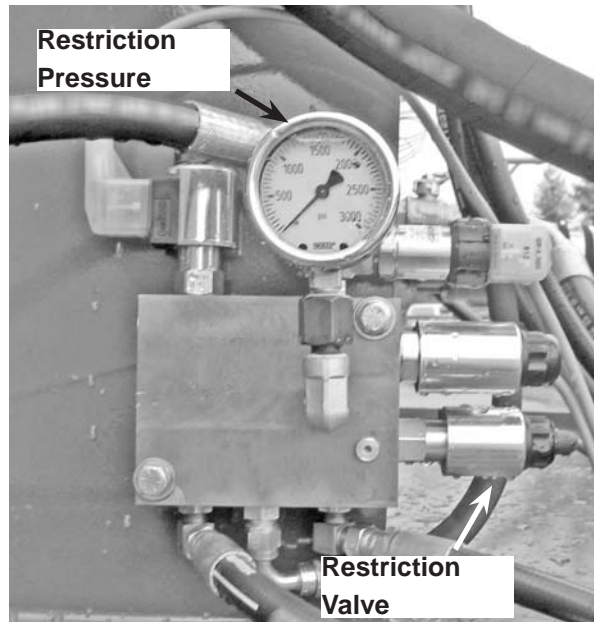

Figure 22 - Restriction System Solenoid Valve

**Note:** Moving the control box RESTRICTION Switch (S-2) from “AUTO” to “MAN” allows the automatic restriction control system feature to be bypassed so that restriction is applied continuously for setting pressures, testing, and troubleshooting.

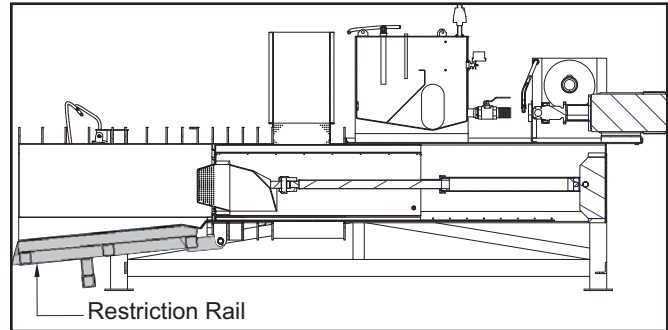

Figure 23 - Restriction Rail Lowered

The pressure in the restriction system is set using the rotary Restriction Pressure pot (see potentiometer on page 13) connected to the valve controller. Turning the pot to Min will decrease the restriction rail cylinder pressure to a minimum of 75 PSI. Turning the pot to its Max setting will increase the restriction rail system pressure to 2500 PSI or system pressure. The valve controller will then limit the pressure across the proportional valves (SV-3).

The restriction rail (see Figure 23), provides a variable restriction (modulation) on the passage of product to the discharge. This restriction regulates the force required from the plunger to push the product toward the discharge. It is the compressing action of the plunger that forces the water from the product. The water is evacuated through the drain holes.

The restriction rail is located at the bottom of the discharge chute. The automatic restriction rail control system controls two hydraulic cylinders that operate the restriction rail. The restriction system proportional valve (see Figure 22) controls the force applied by the restriction rail to the product (dewatering pressure), and is adjusted to obtain the desired water content of the discharged product.

The force requirement depends on the products characteristics. The “freeness” and frictional characteristics should be taken into account when adjusting the restriction system proportional valve setting.

## Starting the WE-5



**CAUTION:** Do not start the equipment until you are certain everyone is clear of the machine and all safety shields are in place.

Follow the steps below when starting your WE-5 Water Extractor. Always make sure SYSTEM CNTRL switch is in STOP position before starting the WE-5. The pump pressure will not exceed 150 psi adding longevity to the hydraulic system.

1. Please read entire WE-5 operators manual before start-up.
2. Make sure reservoir is filled with oil, suction valves are locked in the open position and the pump is primed (see page 4).
3. Push SYSTEM CNTRL switch to STOP (system pressure 150 psi for idle start).
4. Pull EMERG. STOP switch to START position.
5. Turn RESTRICTION switch to AUTO.
6. Turn ANTI-PLUG switch to AUTO.
7. Turn CYCLE MODE switch to TRIG.
8. Pull HYD MOTOR switch to START.
9. Pull SYSTEM CNTRL switch to START (system pressure will equal MAIN PRESSURE pot #3, see page 12).
10. Load material into the feed chute. The plunger will retract according to Product Delay pot #1 when level detector has sensed product for more than 1 second (see Level Detector Adjustments page 14 and Potentiometer Adjustments on page 13).

## Turning off your WE-5

1. Push the SYSTEM CNTRL switch to STOP.
2. Push the HYD MOTOR switch to STOP.

### Emergency shut down

1. Push the EMERG STOP switch (see Figure 21 Page 8). This stops the plunger and kills all power to the water extractor.

## Automatic and Manual Operation

**Automatic Operation** Place the control box SYSTEM CNTRL switch to START, RESTRICTION switch to AUTO, CYCLE MODE switch to TRIG (Activates Level Detector) or CONT (Using Potentiometer settings) and ANTI PLUG switch to AUTO.

**Manual Operation** Place the control box SYSTEM CNTRL switch to STOP, RESTRICTION switch in MAN. Operate lever on directional valve to operate plunger (see Figure 18 page 7).

**Note:** System should be restarted using the **SYSTEM CNTRL switch (S-1) to reset system after any manual operation. RESTRICTION switch back to AUTO.**

## Auto Anti Plug

When the ANTI PLUG switch is set to AUTO, the anti-plugging function is controlled by the DVC-10. The Anti-Plug function provides for automatic clearing of a jammed plug when the restriction pressure is set too high. When the plunger begins to extend, an internal timer begins counting. If the plunger does not fully extend within four seconds, the command signal to the Restriction System Proportional Valve is ramped to zero. The pressure in the restriction system will then begin to bleed down and allow the plunger to force the restriction rails open and move the plug forward.

## Plugging The Chamber

Forming a plug in the chamber is the first step and important part of dewatering your product. The application that you are feeding into the machine will be pushed out the discharge end if there isn't a plug formed first. Each application (vegetable waste, paper pulp, etc.) may act differently when trying to form a plug. Sometimes using loose hay is the only way to start a plug. Keep an eye on the volume of product feeding into the In-feed chute while forming the first plug, the machine may overflow.

1. Follow *Starting the WE-5* instructions on page 10 to start the WE-5.
2. Adjust RESTRICTION PRESSURE Pot #3 to approximately 700psi (see Figure 32 page 13). It may be necessary to adjust this pressure up or down to successfully build a plug.
3. RESTRICTION switch AUTO.
4. SYSTEM CNTRL switch Pull START
5. ANTI-PLUG switch AUTO.
5. EMERG. STOP switch Pull START
6. CYCLE MODE switch CONT. or TRIG.
7. HYD. MOTOR switch Pull START
8. SYSTEM CNTRL switch Pull START
9. Start feeding material into in feed chute. The chamber should start forming a plug after 7 or 8 plunger strokes. Observe the discharge area where the restriction rail should be in its up most position restricting large volumes of product from exiting the machine.
10. The plug is formed. It may be necessary to adjust RESTRICTION PRESSURE Pot #3 up or down to help keep dewatering consistent once the initial startup plug has been pushed out the discharge end.

If a plug couldn't be formed following steps 1 through 7, try using loose hay or call Freeman service department.

## Operation Sequence

### CYCLE MODE Switch: TRIG

1. **START-UP** SYSTEM CNTRL switch in START extends the plunger. AUTO PLUG switch in AUTO raises the restriction rail. Product falling through the in-feed chute falls onto the plunger top surface (see Figure 24).
2. **MATERIAL REACHES LEVEL DETECTOR** The level detector (see Level Detector Adjustments page 14) will send a signal to the DVC program when PROX1 has been activated by product being sensed for more then 1 second (see Figure 25) and the plunger will retract according to pot #1 delay setting.
3. **PRODUCT FALLS INTO CHAMBER** Plunger retracted and the product falls into the chamber. PROX3 and PROX2 activated (see Figure 26 page 12).
4. **PLUNGER EXTENDS** The plunger extend is delayed according to EXTEND DELAY pot #4 (see Potentiometer page 13 for adjustments). AUTO ANTI PLUG starts if the plunger isn't fully extended in 4 seconds (see ANTI PLUG page 10). The chamber is most likely plugged if this occurs (see UNPLUGGING CHAMBER page 15). The plunger passes \*PROX4 (see Figure 29 page 12), and the DVC-10 begins to ramp the directional valve closed. When the plunger passes PROX3, the valve closes all the way.
5. **PLUNGER STOPS** The plunger stops at full extension (home position), product piling on plunger. PROX3 and PROX2 are deactivated (see Figure 27 page 12).
6. **DEWATERING STARTS** Good dewatering starts when product has formed a plug in the chamber with the restriction rail up and the plunger pushing product forward.

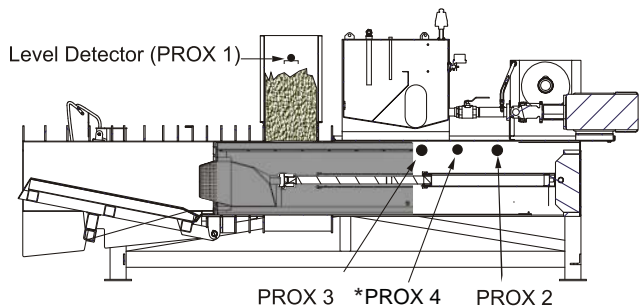

Figure 24 - Product Piling On Top Of Plunger. Plunger In Home Position (fully extended).

\*PROX4 Used only on ASC-0WE5-504 and ASC-0WE5-505



### CYCLE MODE Switch: CONT

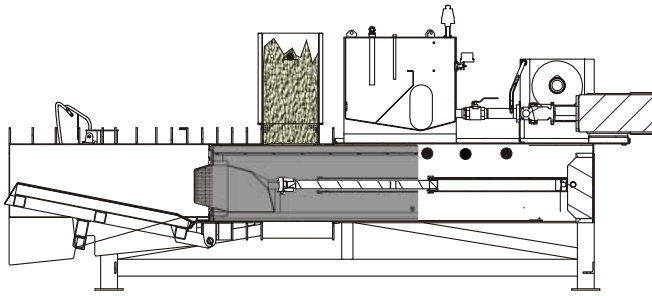

Figure 25 - Product Reaches Level Detector

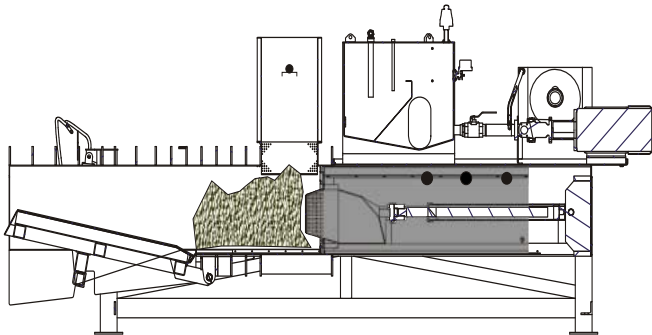

Figure 26 - Plunger Retracts, Product Falls Into Chamber

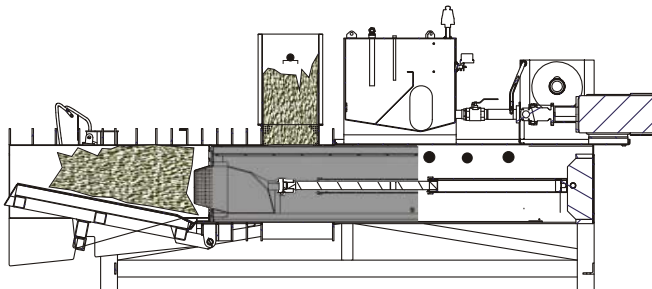

Figure 27 - Plunger Extends, Product Falling On Top Of Plunger

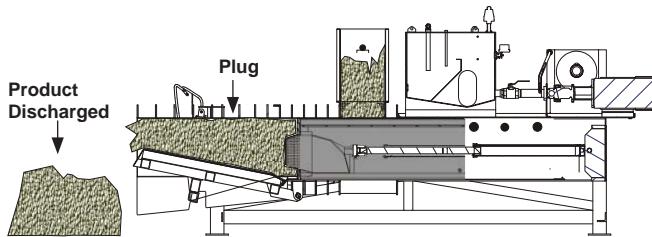

Figure 28 - Plug Formed

**NOTE:** Any time the system is stopped with the EMERG STOP or the SYSTEM CNTRL Switch, when re-started the plunger will return to home position (see Figure 24 page 11).

1. **START-UP** At start-up the plunger is extended and restriction rail is raised. SYSTEM CNTRL switch in START extends the plunger. AUTO PLUG switch in AUTO raises the restriction rail. Product falling through the chute falls onto the plunger top surface.

2. **PLUNGER RETRACTS** The plunger retracts according to PRODUCT DELAY pot #1 (see Potentiometer page 13 for adjustments).

3. **PRODUCT FALLS INTO CHAMBER** The plunger retracts and the product falls into the chamber. The plunger is fully retracted. PROX3 and PROX2 are activated (see Figure 26).

4. **PLUNGER EXTENDS** The plunger extends according to EXTEND DELAY pot #4 (see Potentiometer page 13 for adjustments). AUTO ANTI PLUG starts if the plunger isn't fully extended in 4 seconds (see AUTO ANTI PLUG page 10). The chamber is most likely plugged if this occurs (see UNPLUGGING CHAMBER page 15). The plunger passes \*PROX4 (see Figure 29 page 12), and the DVC-10 begins to ramp the directional valve closed. When the plunger passes PROX3, the valve closes all the way.

5. **PLUNGER STOPS** The plunger stops at full extension and delaying according to PRODUCT DELAY pot #1, PROX3 and PROX2 are deactivated (see Figure 27).

6. **DEWATERING STARTS** Good dewatering starts when product has formed a plug in the chamber with the restriction rail up and the plunger pushing product forward (see Figure 28).

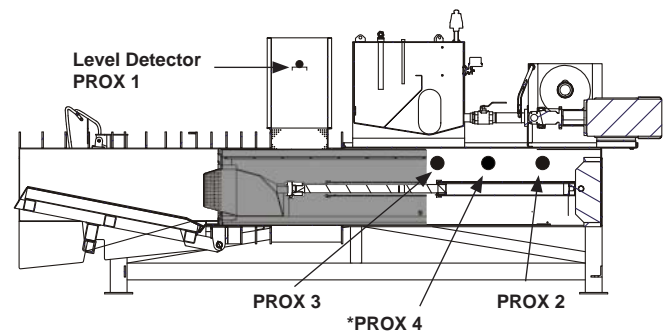

Figure 29 - PROX 3 and PROX 2 Deactivated

\*PROX4 Used only on ASC-0WE5-504 and ASC-0WE5-505

**Potentiometer Adjustments** The Potentiometer (see Figure 30) located in the control box has 4 adjustments; Extend Delay, Restriction Pressure, Main Pressure, and Product Delay.

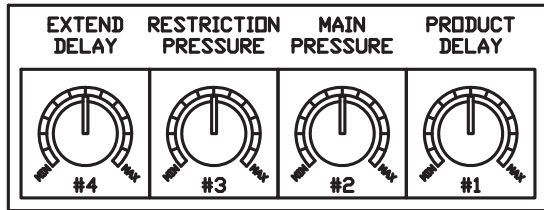

Figure 30 - Potentiometer

**Extend Delay** is set by the Extend Delay Pot #4 shown in Figure 30 (Min being 0 seconds and Max being 15 seconds). This adjustment increases or decreases the time that the plunger remains in the fully retracted position in CONT. or TRIG. CYCLE MODE. Keep this setting close to MIN to avoid shearing (see Figure 31).

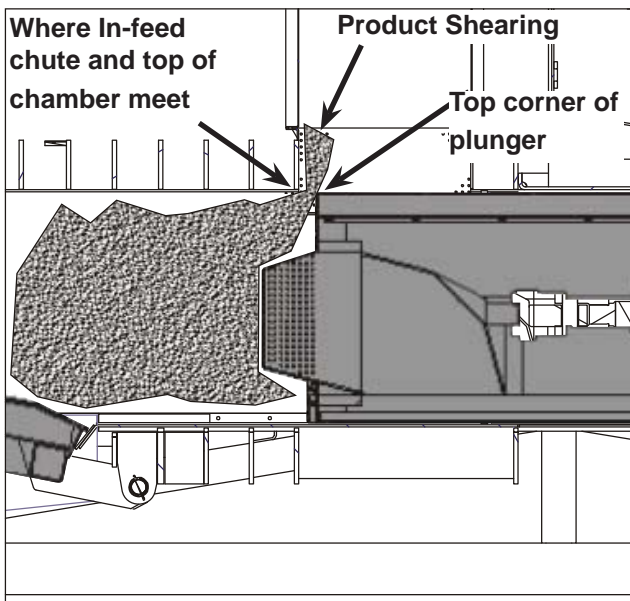

Figure 31 - Product Shearing between plunger and chamber frame.

**Main Pressure** is set by the Main Pressure Pot #2 shown in Figure 15 (Min being 150 psi and Max being 3000 psi). Pressure can be read on the main system pressure gauge (see Figure 18 page 7).

**Restriction Pressure** is set by the Restriction Pressure Pot #3 shown in Figure 30 (Min being 0 psi and Max being 2500 psi). Pressure can be read on the restriction pressure gauge (see Figure 22 page 9). Pressure wont exceed main system pressure.

**Product Delay** is set by the Product Delay Pot #1 shown in Figure 30 (Min being 0 seconds and Max being 15 seconds). This adjustment increases or decreases the time that the plunger remains in the fully extended position in CONT. or TRIG. CYCLE MODE.

Turning pots #1 and #4 fully CCW will set the delays to zero and will allow the plunger to cycle continuously. Turning 1 and 4 pots CW will increase the time delays up to a maximum of 15 seconds.

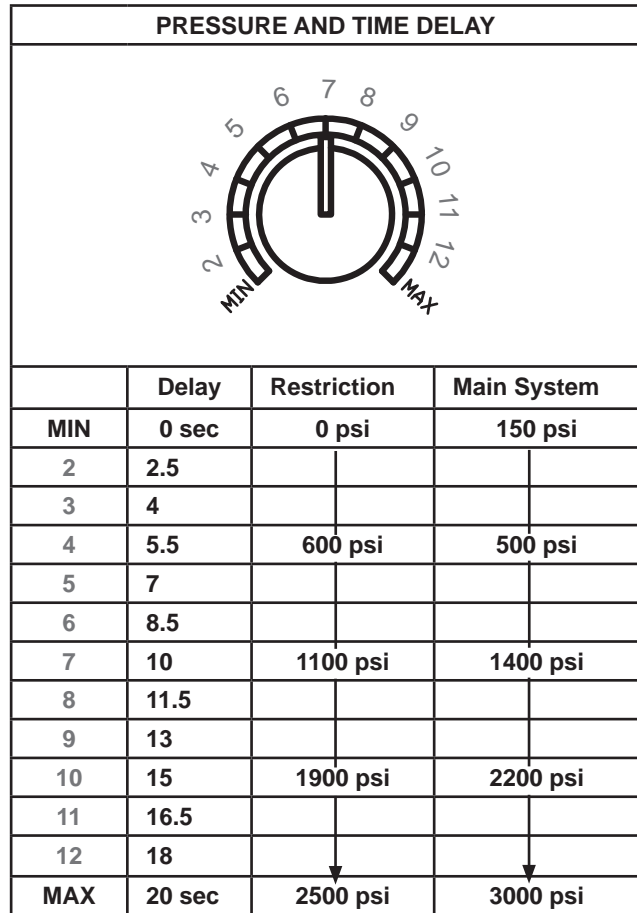



Figure 32 - Pot, Pressure and Delay.

## Level Detector Adjustments

The Level Detector that is located on the side of the in-feed chute (see Figure 33) is active only when CYCLE MODE switch is in TRIG position. The level detector will detect product that sits in front of it for more than 1 second. The level detector will send a signal to the DVC program and the plunger will move according to pot #1 (PRODUCT DELAY) and pot #4 (EXTEND DELAY) setting located inside the panel (see Potentiometer on page 13).

Freeman engineering recommends adjusting potentiometer pot #1 and #4 to MIN for no delay on initial startup. Once the product is detected, the plunger will retract with no delay.



**CAUTION:** Always turn off system control and lockout the electrical supply to the machine before inspecting, adjusting or servicing the machine.

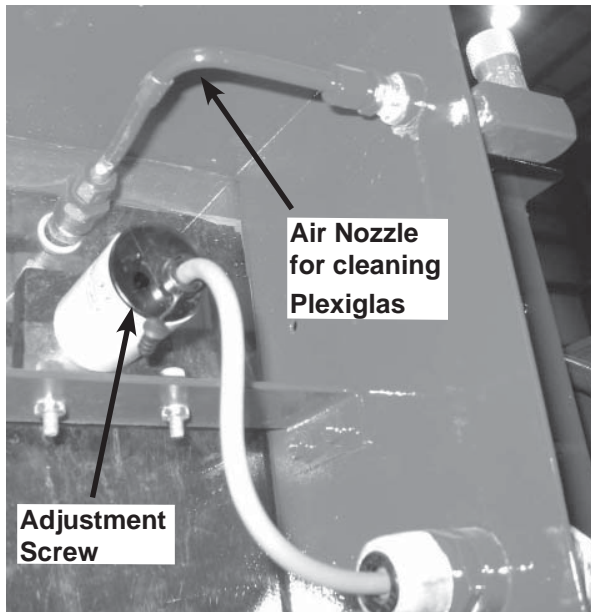

Figure 33 - Level Detector (PROX 1) / Air Nozzle

**Air Nozzle** For cleaning the Plexiglas in front of the Level Detector. Setup for 20 to 60 psi air intake.

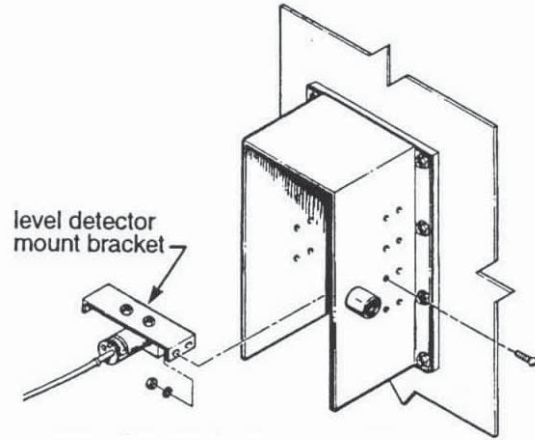

Figure 34 - Level Detector

**Level Detector Vertical Position** There are four vertical positions the level detector can be adjusted to (see Figure 34). Remove mounting hardware and adjust to the preferred level. Tighten hardware.

**Adjust Level Detector Sensitivity** The cover plug at the back of the level detector covers the sensitivity adjustment (Figure 33). Remove the cover plug. The plug provides a seal against dirt and moisture.

**Note:** The level detector sensitivity adjustment screw has no stop. The resistance change of this potentiometer occurs over approximately 16 turns.

Rotating the sensitivity adjustment clockwise increases the detecting distance. Turn the exposed sensitivity adjustment clockwise (+ direction on the detector marking) until the detector switch is turned on (detector light on). Note the position of the screwdriver slot.

Rotating the sensitivity adjustment counterclockwise decreases the detecting distance. Turn the exposed sensitivity adjustment counterclockwise (- direction arrow on the detector marking), noting the number of turns, until the detector switch is turned off (detector light off). Note the number of turns difference between the on and off position.

Now check the sensitivity range of the detector by holding something (piece of cardboard) in front of it. Start out a 3" away from the sensor inside the in-feed chute and slowly move closer to it while watching for the level detectors red light to shine. The plunger will retract once the red light has been on for more than 1 second.

**Replace Cover Plug** Replace the rubber plug at the back of the level detector. The plug provides a seal against dirt and moisture.

## Water Throttling Valve

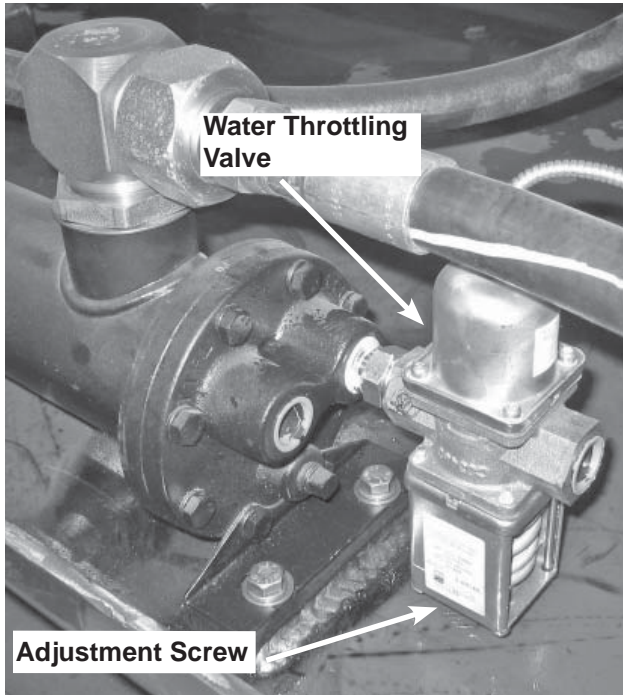

Figure 35 - Throttling Valve

**Adjustment:** Turn the adjusting screw clockwise to DECREASE opening temperature; turn counterclockwise to INCREASE opening temperature. The valve isn't calibrated so desired temperature setting must be established experimentally. Valve is fully open 36°F above opening point.

## Maintenance

### Factory Settings

Plunger extension delay: Not pre-set

Plunger retraction delay: Not pre-set

Maximum Main system pressure: 3000 PSI

Minimum Main system: 150 PSI

Maximum restriction pressure: 2500 PSI

Minimum restriction pressure: 75 PSI (0 psi when ANTI PLUG switch is in MAN or Auto Anti Plug is activated, see Auto Anti Plug page 10).

### Unplugging The Chamber

Chamber plugging should never occur unless foreign material gets into the chamber and causes the chamber to plug up.

**Anti-plug system operation** The control box anti-plug switch energizes the anti-plug solenoid valve (SV-4). The restriction system then opens the restriction rail, permitting the plunger to more easily discharge the product.

**Unplugging steps** There are two ways to unplug the chamber:

1. ANTI-PLUG switch in MAN. with Potentiometer Pots #1 and #4 set to MIN. SYSTEM CNTRL switch START and CYCLE MODE switch CONT. Feed product to the machine while the plunger cycle to push the plug out the discharge end.
2. HAND REMOVAL Move the Anti-Plug switch to MANUAL to open the restriction rail. Turn off water extractor. Use high pressure water or hand tools to manually remove the plugging material.



**CAUTION:** Always turn off system control and lockout the electrical supply to the machine before inspecting, adjusting or servicing the machine.



**WARNING** Pressure greater than 3,000 psi creates a hazard to personnel and can damage the hydraulic system.

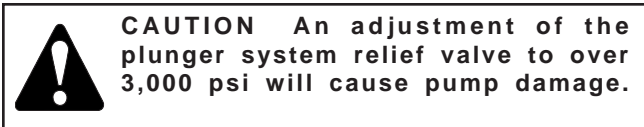

Minimum restriction pressure: 75 PSI (0 psi when ANTI PLUG switch is in MAN or Auto Anti Plug is activated, see Auto Anti Plug page 9).

**Safety Precautions** If maintenance or repairs are to be performed on machine, the following precautions should be observed.

Shut down the system and lock out the hydraulic pump motor and the cooling fan motor at the disconnect switch.

On some machinery, cylinders hold heavy loads. Opening the hydraulic lines with the load raised may permit the load to fall. Hydraulic lines can inadvertently be opened by disconnecting a hose, pipe, or by removing a high pressure filter bowl to change the element. On such machinery, the load should be lowered to rest position before disturbing the hydraulic circuit.

**Maintenance Precautions** Think clean!!! The worst enemy of a hydraulic system is contamination. As long as your system is intact, it is nearly impossible for dirt to get into the oil. Dirt gets into the oil when you provide an opening. It can enter through holes left uncovered when you remove some component such as a valve, breather or cap.

If you adhere the following procedure, you will not let dirt into the system.

Clean and wash down the entire area that is going to be worked on. Before removing any component or disconnecting any line, be sure you have the right caps, plugs and cover plates to close the openings that will be exposed.

Thorough cleaning of pipe and hoses before installing or reconnecting is essential. Whenever a pipe or hose is disconnected, or a system component is removed, the system may have to be flushed. For flushing instructions see page 17.

When field repairs on the components are made, flushing the components is necessary. See page 17 for Flushing instructions.

**Disassembly of components will void any warranty considerations. Components must be shipped to Allied Systems Co. fully assembled.**

Once you have replaced hoses or components, air and contaminants have a chance to enter the system. You must purge the pump for at least 10 minutes to get air out of the system. You may run your pressure up to 3000 once all air is out of the system.

**Sight Gauge** An oil level gauge is installed on the reservoir. It will indicate oil level and approximate oil temperature.

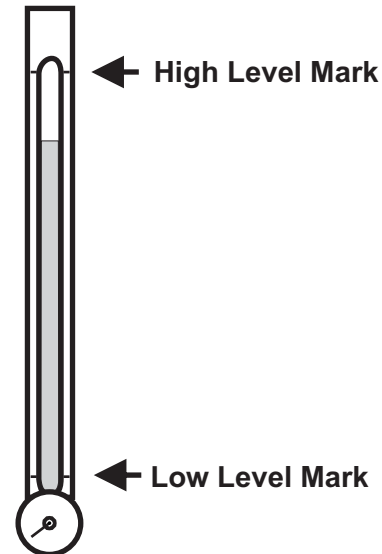

Figure 36 - Oil level sight gauge

**Reservoir Oil Level** Oil Level Float switch is installed to detect the oil level. Motor starter shuts off when oil level is 1" below the low level mark. The reservoir is full when the Oil level is 2" to 3" below the High Level Mark with cylinders extended (see Figure 36).

**Oil Temperature** A dual set point temperature switch is installed to detect oil temperature in the system. If the oil reaches the temperature set on the high circuit adjustment, the switch will automatically shut down the system and turn on an indicator light. The lower setting controls operation of the fan motor and the oil cooler.



**Warning Avoid high-pressure fluids.** Escaping fluid under pressure can penetrate the skin, causing serious injury. Keep hands and body away from pinholes and nozzles which eject fluids under high pressure. Use a piece of cardboard to search for leaks. If any fluid is injected into the skin, it must be surgically removed within a few hours by a doctor familiar with this type injury or gangrene can result.

**Pump and Motor Coupler** The coupling alignment must be within 0.003 total indicator reading on the horizontal, vertical, and angular planes. Adjust as necessary.



**WARNING** Pressure greater than 3,000 psi creates a hazard to personnel and can damage the hydraulic system.

**Procedure To Fill an Empty Reservoir** Reference page 4 for hydraulic oil recommendations.

Clean the area around the power unit “fill port”.

Install a clean filter element in the return line filter.

Pump one gallon of oil into a waste container to flush the filter pump and hose. **Do not use this oil.**

Remove the cap from the “fill port”.

Fill the reservoir. If this is a start-up, see Reservoir Oil Level on page 16.

When reservoir is filled to the “full” index mark on the reservoir’s oil level sight gauge, replace cap on fill port.

Open the return line shut-off valve.

**Procedure to Add Oil to the Reservoir** Reference page 4 for hydraulic oil recommendations.

Lockout the pump at the disconnect switch.

Clean the area around the power unit “fill port”.

Pump one gallon of oil into a waste container to flush the filter pump and hose. **Do not use this oil.**

Remove the cap from the “fill port”.

Fill the reservoir to the “full” index mark on the reservoir’s oil level sight gage.

Close the “fill port” valve and disconnect the filler hose. Replace cap on fill port.

Remove lockout from the disconnect switch.

### **To Change Oil and Clean a Contaminated Reservoir**

Lockout the pump at the disconnect switch.

Completely drain the reservoir, return line filter housing and return lines.

**DO NOT attempt to reuse this oil if it does not conform to original manufacturer’s specifications. This oil MUST be filtered and then tested by the original manufacturer.** The oil must conform to the original manufacturer’s specification before reusing, if it does not conform to original manufacturers’ specifications, catastrophic failure may occur.

Remove the end cover, clean debris out of reservoir and wipe inside completely clean. Install a new gasket and replace cover.

Install a clean element in the return line filter.

Fill reservoir with new oil (see Figure 11 page 5).

**Flushing** Allied Systems requires a complete system flush after installation, after intrusion into the system or after a catastrophic failure. Actuator flushing is required when prescribed in certain actuator repair procedures and after catastrophic failure.

Most systems can be properly flushed by utilizing the power unit system pump (s) to circulate fluid out through the fluid lines and back through the filter into the reservoir.

Verify the proper amount and type of filtered oil is in the reservoir.

Verify enough spare filter elements for all filters are on site before beginning the flushing process. Note: Use only the Allied Systems Co. specified brands and types of filter media.

Avoid flushing through any valves or actuators. These items are pre flushed by Allied Systems Co. or the manu-

facturer. Loop the existing field installed hose assemblies around these components using unions, with the exception of the power unit blocking valve. Once flushing has started, it is common to get surges of air from the fluid lines into the reservoir, which may cause the pumps to be noisy as air bubbles are drawn into the pump. If the noise persists for long periods of time, and the fluid is aerated or foamy, stop the flushing process and allow the fluid to settle out overnight. If the noise persists beyond a reasonable period of time, consult the manufacturer.

Turbulent flow is essential to all flushing procedures. To achieve this, the Reynolds number (Re) must exceed 4,000 throughout the system. It is calculated as follows:

$$(Re) = (14,646 \times Q) / (v \times d)$$

Where Q = flow rate in GPM, d = pipe I.D. in inches, v = viscosity of fluid in SSU.

Flush only one leg of the system at a time to insure that the proper flow velocity and Reynold's Number (Re) is achieved in each leg. Cap off the other legs.

If necessary, tie multiple pumps together to achieve proper (Re) in each leg of the circuit.

Turbulent flow may also be achieved by vibrating or flexing the lines. Back off the pilot chokes and allow the blocking valve to suddenly open, causing the accumulator oil to surge through the system, giving a temporarily high Reynolds Number ( $R_e$ ).

The system must be flushed so the oil cleanliness meets Allied Systems ISO cleanliness codes 20/17/14. A starting rule of thumb is to flush for a minimum of one hour per 100 ft. of pipe and hose (total of pressure and return lines). While flushing, strike all welds with a hammer to dislodge any scale created as a result of welding.

Before the system may be started-up, the oil **must** be sampled and tested to meet Allied Systems ISO cleanliness codes 20/17/14. This includes every component in the system, especially servo valves and pumps.

**If the oil does not meet the ISO cleanliness codes 20/17/14, it could reduce component life or cause Catastrophic Failure, and system flushing must continue.**

After flushing is completed, first verify that the oil cleanliness meets Allied Systems ISO cleanliness codes 20/17/14, then verify that no filters are indicating impending bypass. Also verify a supply of spare filter elements are on hand.

Reconnect hoses to actuators & valve packages. Start the pump motor and check for leaks in the entire system.

Warning!!! When the pump is restarted after the flushing procedure has been completed, the actuators may move suddenly.

**Be sure the machinery is clear of all objects and people.**

## **Preventative Maintenance**

### **Daily**

Check oil level in power unit reservoir.

Check oil temperature at temperature gauge.

Check heat exchanger for any debris that may be blocking the fins, and use air to blow the debris out.

If the system is operating, the temperature should be between 100 °F and 120 °F.

Check for leaks around power unit.

### **Weekly**

Perform daily service.

Check entire system for leaks.

Check pressure gauge settings.

Check all visual dirt indicators on all filters (Note: Most indicators work only when under full flow condition).

### **Monthly**

Perform Daily & Weekly service.

Clean up any oil that may be in the drip pan.

Check the electric motor to pump coupling insert for alignment and wear and lubricate.

Check reservoir temperature first thing before starting up. The temperature should be at least 80 °F.

### **Three Months**

Perform Daily, Weekly, and Monthly Service.

Sample the oil for cleanliness, viscosity and additives. Check for lubrication of the electric motor.

**DVC-10**

Note:

If any solenoids are disconnected, the DVC10 will detect an open circuit and will not operate these valves after reconnected until the DVC10 power is cycled. Power may be cycled using the Emergency Stop switch.

Proximity sensors should be adjusted between 3/16" and 1/4" from triggers .

Properly working sensors must provide a signal back to the DVC10. If there is not a light indicating operation on the DVC10 body, this may be checked most easily at the terminal block. The plunger sensors are normally open and provide a 20 - 24 v signal to the DVC10 when activated while the product sensor is normally closed and removes it's 20-24v signal when triggered.

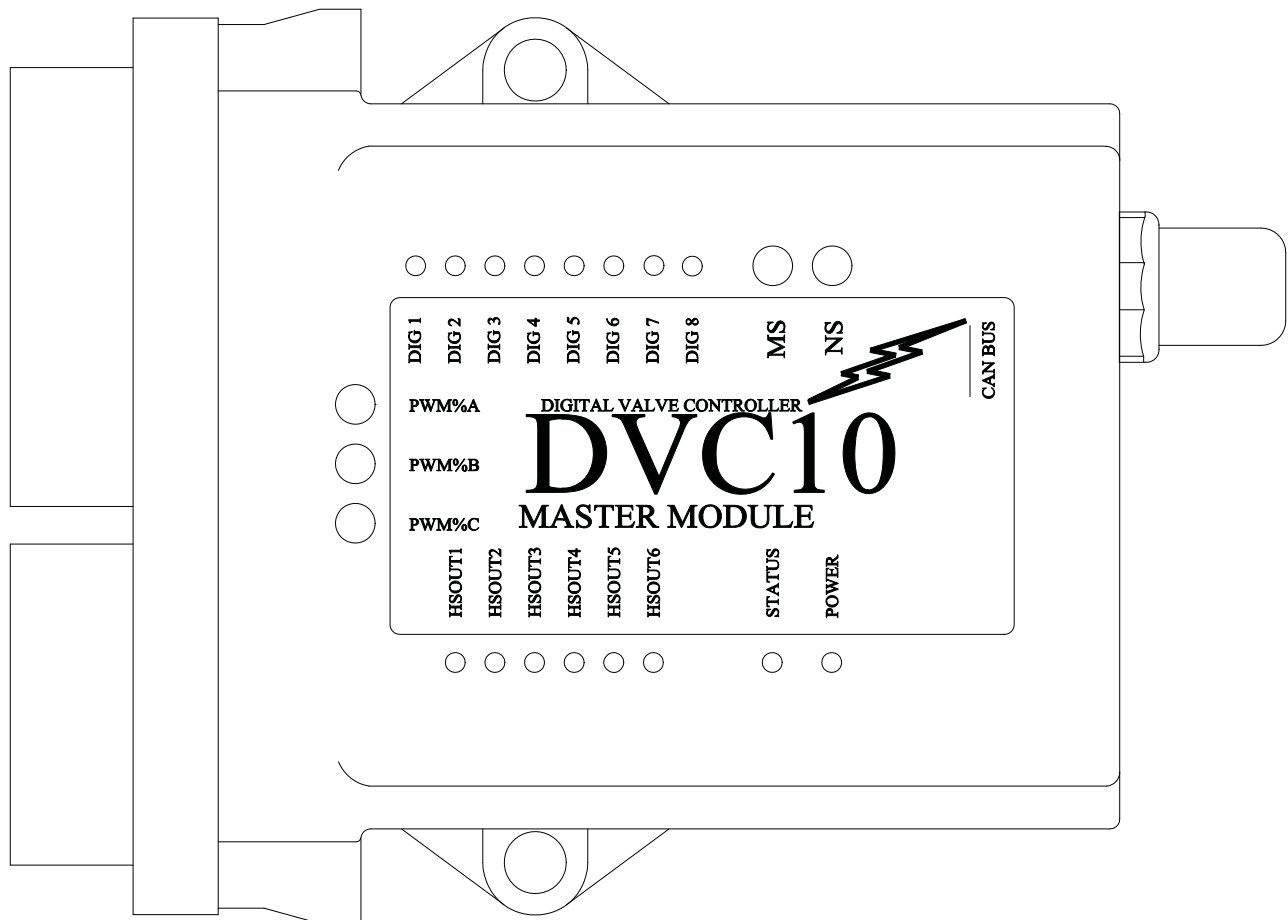

Figure 37 - DVC-10



### **DVC-10 Continued**

<b>LED</b>	<b>Function</b>		<b>Normal (Powered) Condition</b>
MS	Module Status		Lit (green) after power-up. While downloading a program to the module, MS and NS LED's will flash in an alternating fashion.
NS	Network Status		Lit or flashing after power-up. While downloading a program to the module, MS and NS LED's will flash in an alternating fashion.
DIG1	Not Used Before ASC-0WE5-504	Ramp Sensor used on S/N ASC-0WE5-504 and after.	Green light on.
DIG2	Cycle Mode		CONT. Green light on.
DIG3	Product Level Detector (PROX 1)		MANUAL Green light on.
DIG4	Plunger Retracted Proximity Switch. (PROX 2)		Green light on.
DIG5	Plunger Extended Proximity Switch. (PROX 3)		Green light on.
DIG6	SYSTEM CNTRL Switch		START Green light on.
DIG7	RESTRICTION Switch		AUTO Green light on.
DIG8	Anti-Plug Switch		AUTO Green light on.
PWM%A	Not Used		N/A
PWM%B	Restriction Pressure		Green light on when pressure at 75 psi. and gradually turns solid red at 3000 psi.
PWM%C	Main System Pressure		Green light on when pressure at 75 psi. and gradually turns solid red at 3000 psi.
HSOUT1	Plunger Retract		Green light on.
HSOUT2	Plunger Extend		Green light on.
HSOUT3	Restriction Solenoid		Green light will be on if Anti-Plug is inactive and plunger is extending (switch in auto mode) or Anti-Plug is inactive and restriction is in manual mode
HSOUT4	Anti-Plug Solenoid		Green light on when in Manual or 90% of system pressure.
HSOUT5	Pump Control Power		Green light on only when pump is on.
HSOUT6	Not Used		N/A
STATUS	Not Used		N/A
POWER	Power Indicator		Lit after power-up

**Pump**

Symptom	Probable Cause	Remedy	Reference
Excessive pump noise	1. Pump/motor coupling misalignment.	Re-align pump & motor accurately. Align to within .003" total indicator reading. Note: Couplings should not be forced tight against each other. Leave a small amount of end play.	
	2. Oil level low.	Fill reservoir so that surface of oil is 2 to 3" below the full mark with cylinders extended.	Page 16
	3. Air leak in suction line, air leak in case drain line, or air leak around shaft packing.	Apply packing grease on joints & around shaft while listening for change in sound of operation. Tighten or replace.	
	4. Direction of pump rotation not correct.	A licensed electrician should check the Input Phase.	Page 3
	5. Air bound pump.	Air is locked in pumping chamber & has no way to escape. Stop pressure line or install special bypass line back to tank so that air can pass out of the pump. An air bleed valve need is indicated.	
	6. Restricted flow through suction piping.	Check suction piping & fittings to make sure full size is used throughout. Make sure suction line is not plugged with rags or other foreign material.	
	7. Pump case drain does not terminate below oil level.	Extend slip line piping so that it terminates below the oil surface when oil is at its lowest during any part of one machine cycle.	
	8. Pressure ring is worn.	Replace. This condition caused by hot, thin, dirty oil or no oil at all. An air bound condition will also contribute to the worn pressure ring.	

***Pump continued***

Symptom	Probable Cause	Remedy	Reference
Excessive pump noise (cont.)	9. Restricted filter or strainer.	Clean filter or strainer.	Page 5
	10. Worn or broken parts.	Replace.	
	11. Reservoir air vent plugged.	Air must be allowed to circulate in the reservoir. Clean and /or replace breather.	Page 5

***Filter***

Dirty Oil	1. Plugged Cartridge.	Replace Cartridge.	
	2. Partial bypass continuous.	Correct filter size and oil viscosity.	
	3. Improper micrometer rating.	Check particle size and switch to proper size rating.	
	4. Improper changes.	Correct maintenance procedure or add bypass indicator.	

**Filter Continued**

Symptom	Probable Cause	Remedy	Reference
Bearing failure	1. Chips or other foreign matter in bearings (contamination).	Make sure clean oil is used. Essential for efficient operation & long life of bearings.	
	2. Coupling misalignment.	Re-align pump & motor.	
Pump not delivering oil	1. Wrong direction of pump rotation.	Observe arrow on pump case of name-plate. Direction of rotation must correspond.	Page 3
	2. Oil level low in reservoir.	Fill reservoir so that surface of oil is 2 to 3" below the full mark with cylinders extended.	Page 16
	3. Air leak in suction line.	Apply good pipe compound non-soluble in oil & tighten joints.	
	4. Suction filter or plugged line.	Filters must be cleaned of lint or dirt soon after first start of unit. Periodic checks should be made as a preventive maintenance precaution.	
	5. Bleed-off in other portion of circuit.	Check for open center valves or other controls connected to tank.	
	6. Oil viscosity too high for proper priming.	Thinner oil should be used per recommendations for given temperatures & service.	
	7. Sheared key at rotor or coupling	Check and replace.	
	8. Pump cover too loose.	Tighten bolts on pump cover.	
Pump not delivering pressure	1. Pump pressure not set high enough	Contact Allied Systems Co. Service Department.	
	2. Oil by-passing to reservoir.	Inspect circuit pressure progressively. Watch for open center valves or other valves open to reservoir.	
	3. Defective pressure gauge or gauge line is shut off. Dirt may plug gauge orifice.	Install good pressure gauge in a line open to pump pressure.	

### **Filter Continued**

Symptom	Probable Cause	Remedy	Reference
System excessively hot	1. Pump operates at higher pressures than required	Contact Allied Systems Co. Service Department.	Page 16
	2. High ambient temperature.	Relocate power unit or baffle against heat source.	
	3. Oil in reservoir low.	Raise oil level to recommended point.	
	4. Internal System leakage excessive.	Check progressively through the system for losses.	
Leakage at oil seal	1. Seal installed incorrectly.	Correct installation.	Page 16 and 17
	2. Pressure in pump case.	Observe case drain line for restriction. Check drain line circuitry for excessive back pressure arrangement.	
	3. Poor coupling alignment.	Re-align pump & motor shafts. Align to within .003" total indicator reading.	
	4. Seals damaged during installation. Damaged or scratched shaft seal.	Contact Allied Systems Co. Service Department..	
	5. Abrasives on pump shaft.	Protect shaft from abrasive dust & foreign material.	
Bearing failure	1. Abuse during coupling installation to pump	Most pumps are not designed to handle end thrusts against the drive shaft. Eliminate excessive force when installing coupling. Couplings should be a slip fit onto the pump shaft.	Page 5
	2. Overhung load.	Many pumps are not designed to handle any overhung load or side thrust on the drive shaft. Contact Allied Systems Co. Service Department.	
	3. Incorrect fluid	See manufacture's oil recommendations.	
	4. Excessive or shock load	Contact Allied Systems Co. Service Department.	

**Gauges**

Symptom	Probable Cause	Remedy	Reference
Incorrect indication	1. Gauge defective	Check zero pressure & remedy or replace broken tube, broken movement, tube spring, broken needle, pegged needle or gauge pinion gear.	
	2. Check accuracy	Check gauge against calibration standard.	
Poor gauge life	1. Gauge subject to mechanical shock.	Isolate shock by switching to glycerin filled gauge.	
	2. Bourdon tube fatigue	Use gauge isolator to remove continuous pressure on tube.	
	3. Pegged needles	Add pressure flow snubber to restrict needle movement in addition to glycerin (or fluid filled gauge).	
Broken housing	1. Too much pressure	Remove downstream restriction or change to corresponding higher pressure or flow rated filter.	
	2. Too much mechanical shock.	Add shock absorbing material.	
Broken Lens	1. Some degreasers will scratch or "fog" up lens	Replace gauge.	

### **Machine Function**

Symptom	Probable Cause	Remedy	Reference
Adjustments don't seem to work	Not enough time for adjustments to be noticed.	Wait for a minimum of 10 plunger strokes before beginning to judge the effect of the adjustment.	
Plugging	Plunger stalls and motor overload device is tripped.	Reduce restriction pressure.	
Jerky plunger stroke	Air in oil.	The air is most likely between the reservoir and the pump. Replace reservoir filter and make sure fittings are tight between reservoir and pump.	
	Worn or defective plunger piston seals.	Replace piston seals.	
	Intermittent solenoid valve action.	Loose electrical connection. Bad solenoid. Check electrical connection. Replace solenoid.	
	Defective pump.	Replace or have factory service the pump.	
Slow plunger stroke	Air in oil.	The air is most likely between the reservoir and the pump. Replace reservoir filter and make sure fittings are tight between reservoir and pump.	
	A nonstandard size pump.	Only use a pump recommended from Allied Systems.	
	Worn or defective plunger piston seals.	Replace piston seals.	
	A restriction in the hydraulic system.	Replace filter in reservoir.	



To find a dealer in your area,  
Call: 503-625-2560,  
Fax: 503-625-7269, or

Visit our website: <http://www.alliedsystems.com>

**Allied Systems**  
C O M P A N Y

PBWE5OPS08 7/08  
Printed in USA