

# FREEMAN

---

## MODEL 7000 PULL TYPE BALE WAGON OPERATOR MANUAL



STARTING WITH S/N ASC-7000-004

**Important:** Be certain to specify the serial number of your Bale Wagon when ordering parts.

**PB7000OP13**

Allied Systems Co. reserves the right to make changes to new equipment without incurring the obligation to make such changes to equipment previously manufactured.

---

## BALE WAGON SERIAL NUMBER AND PARTS ORDERING INFORMATION

Each Freeman Bale Wagon is identified by means of a model number and serial number. The serial number is an important piece of information about the machine and it is necessary to know it before obtaining the correct replacement part. The serial number is located on the left front frame. To ensure prompt, efficient service when ordering parts or requesting repairs from your authorized Freeman dealer, record the serial numbers in the spaces provided.

### Bale Wagon Serial Number

---

Left front side of Bale Wagon.

NOTE: Reference to left-hand and right-hand used throughout the manual are understood to mean from a position facing in the direction of travel.

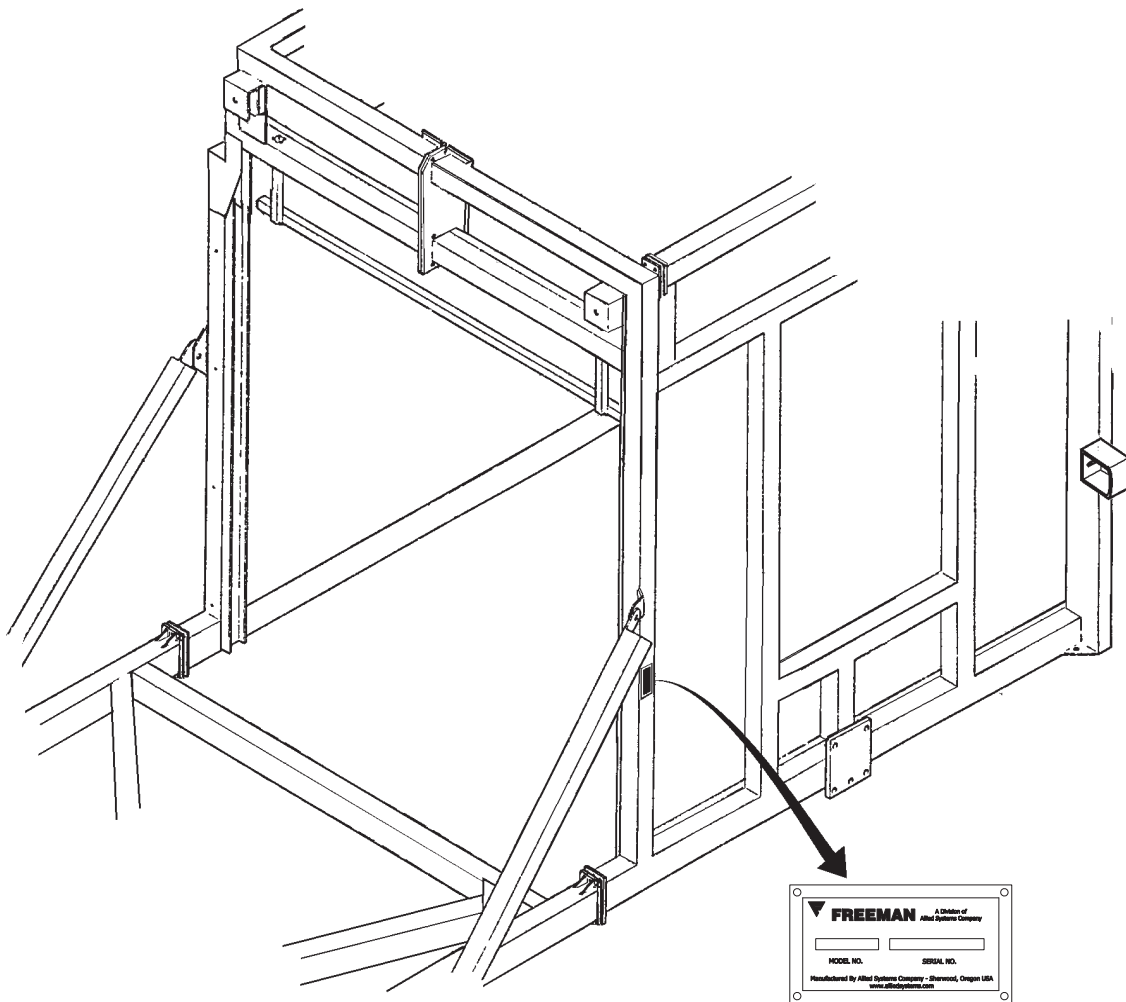

Serial Number Plate located on left front frame of Bale Wagon.

This manual applies to the following bale wagon serial numbers: ASC-7000-004 to Current



## WARNING

Some illustrations in this operator's manual show the Bale Wagon without shields to allow for a better view of the area being addressed. The machine should never be operated with any of the safety shields removed.

## Safety

### General

The following pages contain general safety warnings which supplement specific warnings and cautions appearing elsewhere in this manual. All electrical and hydraulic equipment is potentially hazardous. You must thoroughly review and understand this Safety Section before attempting to operate, troubleshoot, maintain or service this bale wagon.

Time, money and effort have been invested in making your bale wagon a safe product. The dividend from this investment is **YOUR PERSONAL SAFETY**.

However, it must be realized that no power-driven equipment can be any safer than the person behind the controls. If you don't operate and maintain your Freeman bale wagon safely, our efforts will have been in vain.

The safety instructions and warnings, as documented in this manual and shipped with the machine, provide the most reliable procedures for the safe operation and maintenance of your bale wagon. It's your responsibility to see that they are carried out.

Allied Systems Company cannot anticipate all worksite conditions, local regulations, etc. It is the responsibility of the end user to be aware of and obey any specific worksite, local, state, or national regulations or procedures that are applicable to operating this bale wagon.

**NOTE: All possible safety hazards cannot be anticipated so as to be included in this manual. Therefore, you must always be alert to potential hazards that could endanger personnel and/or damage the equipment.**

#### Intended Use Statement:

*This bale wagon is intended to gather and stack 45" - 48" long, 14", 15" or 16" 2-Tie and 3-Tie bales of hay from the field in which they were formed. Use in any other way is considered to be contrary to the intended use. If you are unsure of the material you intend to gather, consult the factory.*

### Safety Symbols

The following symbols/terms are used to emphasize safety precautions and notices in this manual:



## DANGER

The "DANGER" symbol indicates a hazardous situation which, if not avoided, will result in death or serious injury. Carefully read the message that follows to prevent serious injury or death.



## WARNING

The "WARNING" symbol indicates a hazardous situation which, if not avoided, could result in death or serious injury. Carefully read the message that follows to prevent serious injury or death.



## CAUTION

The "CAUTION" symbol indicates a hazardous situation which, if not avoided, could result in minor or moderate injury, or equipment damage. Carefully read the message that follows to prevent minor or moderate injury.

## NOTICE

The "NOTICE" symbol alerts to a situation that is not related to personal injury but may cause equipment damage.

#### NOTE: ...

The term "NOTE" highlights operating procedures or practices that may improve equipment reliability and/or personnel performance, or to emphasize a concept.

## Operation Warnings



# WARNING

Failure to observe the following safety rules may result in extreme personal injury, dismemberment or death. It is the operator's responsibility to understand the proper and safe use of this bale wagon.

- Make sure that you read, understand, and obey all of the safety precautions and operating instructions in this Operator's Manual.
- Keep this Operator's Manual with the bale wagon at all times.
- Do not operate the bale wagon unless you are authorized and trained to do so. If it has been some time since you last operated the bale wagon, re-familiarize yourself with the bale wagon before starting, then proceed slowly.
- Do not operate the bale wagon if you are aware of any malfunctions, needed maintenance or repairs.
- Stop the bale wagon immediately if any problems arise.
- Never allow others to ride on the bale wagon.
- Never allow anyone within 10 ft (3 m) of the bale wagon while the bale wagon is in operation.
- Never operate the bale wagon without all safety shielding in place.
- Keep hands, feet, hair, jewelry and clothing away from moving parts, including but not limited to the pickup, elevator, bale table and PTO shaft.
- Avoid wearing loose clothing which can easily be caught in moving parts.
- Use appropriate signs (i.e., Slow Moving Vehicle sign), signals or warning lights when transporting on highways.



- Always use lights when working at night or in low light conditions.
- Know your job-site rules. Some have site specific directions and procedures. The methods outlined in this manual provide a basis for safe operation of the bale wagon. Because of special conditions, your company's stacking procedures may be somewhat different from those shown in this manual.
- Do not start the tractor if the key has been marked with a "DO NOT START" or "RED" tag.
- Never operate any of the tractor's controls from anywhere other than the operator's seat.
- Alert personnel in the area before starting the engine, and make sure everyone is clear. Be sure that all controls are in neutral and the bale wagon is disengaged before starting the engine.
- Each country has its own safety legislation. It is in the operator's own interest to be conversant with these regulations and to comply with them in full. This also applies to local bylaws and regulations in force on a particular worksite.
- Should the recommendations in this manual deviate from those in the user's country, the national regulations should be followed.
- Never attempt to disconnect any of the safety devices built into the bale wagon or tractor.
- Maintain proper clearance from energized equipment, energized power lines or other power sources. High voltage electricity can discharge to ground without direct contact with the bale wagon's or tractor's structure. If the bale wagon or tractor contacts energized equipment, or if electrical energy does discharge through the machine—stay clear, and prevent anyone else from coming in contact with the bale wagon or tractor. If you are on the tractor, stand fast, avoid contact with metal surfaces, and do not permit anyone to come into contact with the tractor or bale wagon. Finally, **Do not jump off.**

## Hydraulic Hazards

Be aware of the hazards of pressurized hydraulics:

- Wear personal protective equipment, such as gloves and safety glasses, whenever servicing or checking a hydraulic system.
- Assume that all hydraulic hoses and components are pressurized. Relieve all hydraulic pressure before disconnecting any hydraulic line.
- Never try to stop or check for a hydraulic leak with any part of your body; use a piece of cardboard to check for hydraulic leaks.
- Small hydraulic hose leaks are extremely dangerous, and can inject hydraulic oil under the skin, even through gloves.
- Infection and gangrene are possible when hydraulic oil penetrates the skin. See a doctor immediately to prevent loss of limb or death.



## Maintenance Safety

- Perform all routine maintenance outlined in this Operator's Manual in the time intervals indicated.
- Maintenance, lubrication and repair of this machine can be dangerous unless performed properly. In order to ensure safety, each person working on this bale wagon must have the necessary skills, information, tools and equipment, and satisfy himself that his work method is safe, correct, and meets his own company's requirements.
- Do not attempt to make adjustments, or perform repairs unless you are authorized and qualified to do so.
- Never attempt to service energized equipment alone. Someone capable of rendering aid in the event of accidental shock must be present.
- Do not rely on the hydraulic system to support any part of the bale wagon during maintenance or lubrication. Never stand under a bale wagon component that is supported only by the hydraulic system. Ensure components are resting on their mechanical stops or supported with appropriate safety stands during maintenance or lubrication.
- Never attempt servicing while the bale wagon is moving. Shut off the tractor and secure power.

- Shut off tractor engine, engage the parking brake, disengage the bale wagon, and wait for all movement to stop before adjusting, lubricating, cleaning, or servicing the bale wagon.
- Tag the key switch with a "DO NOT START" sign and/or remove the key.
- Always perform all maintenance and lubrication procedures with the bale wagon on level ground, parked in a safe area.
- Block the tires to keep the machine from rolling.
- Any unauthorized modifications made to the bale wagon by the customer or parties other than Allied Systems will relieve Allied Systems Company and your Freeman dealer of any liability for damage or injury.
- Replace any worn parts only with genuine Freeman parts. Call your dealer for assistance.
- Unless specified in service procedures, never attempt maintenance or lubrication procedures while the bale wagon is moving or the engine is running.
- Engine exhaust fumes can cause death. If it is necessary to run the engine in an enclosed space, remove the exhaust fumes from the area with an exhaust pipe extension. Use ventilation fans and open shop doors to provide adequate ventilation.
- Batteries contain sulfuric acid which can cause severe burns. Avoid contact with skin, eyes or clothing.



- Batteries produce explosive gases. Keep sparks, flame and cigarettes away. Ventilate when charging or servicing in an enclosed space. Always shield your eyes when working near batteries. When removing battery cables, disconnect the negative (-) cable first. When installing a battery, always connect the positive (+) cable first. This procedure will help to prevent a spark which could cause an explosion.



- Before making adjustments to the engine or chassis electrical system, disconnect the battery. An electrical spark could cause a fire, explosion or severe burns.

### Safety Equipment

- Ensure test equipment is in good condition.
- If an instrument must be held while taking measurements, ground the case of the instrument before energizing equipment.
- Do not touch live equipment or personnel working on live equipment while holding a multimeter. Some types of measuring devices should not be grounded—do not hold such devices while taking measurements.
- Prevent personal injury or equipment damage by using a lifting device with a lifting capacity greater than twice the weight of any equipment to be lifted.
- Always use personal protective equipment (PPE) appropriate to the situation. This may include the use of hearing protection, eye protection, a respirator, a hard hat, leather gloves, steel toed boots, etc.



### Electrical Hazards

- An electric shock could be fatal. Ensure power to the bale wagon is “OFF” before opening electrical panels.
- All electrical cables and connectors must be in good condition (free of corrosion, damage, etc). Use caution in wet weather to avoid danger from electrical shock. Never attempt electrical testing or repair while standing in water.
- Do not wear electrically conductive jewelry, clothing, or other items while working on the electrical system.



### Welding

Before conducting any welding on the Bale Wagon:

- Disconnect both the white power supply wire and the black ground wire.
- Disconnect the highway light cord (7 Pole Connector).
- Unplug both MC2 and XA2 modules located in the Main Control Panel.
- Unplug the Tractor control Box.

### Hot Oil Hazards

- Burns from hot oil can be severe—Always allow lubricating and hydraulic oil to cool before draining.

### Compressed Air Hazards

- When using compressed air to dry parts, pressure should not exceed 30 psi (200 kPa).
- Air pressure penetrating your skin can be fatal. Never direct compressed air at anyone.

## Fire Safety



### WARNING

**Diesel fuel and hydraulic oil are flammable. Never smoke while handling fuel or working on the fuel system. The fumes in an empty fuel container are explosive. Never cut or weld on or near fuel lines, tanks, or containers. Keep open flames and sparks away from the machine.**

## Reduce the Risk of Fire

- Keep the bale wagon free of oil, grease, hay, and trash accumulations. Regular cleaning is recommended for fire prevention and general safety.
- Shut off the engine and electrical equipment while filling the fuel tank. Use extra caution when fueling a hot engine. Always ground the fuel nozzle against the filler neck to avoid sparks.
- Never overfill the fuel or hydraulic tanks. Any overflow could cause a fire. Immediately repair any hydraulic or fuel leaks and clean up any spills.
- Handle all solvents and dry chemicals according to procedures identified on manufacturer's containers. Work in a well-ventilated area. Make sure you know where fire extinguishers are kept and how to use them.
- Avoid spilling fuel or other hazardous liquids. If a spill occurs, follow local or state regulations for clean-up. Contact your state's OSHA office for details.
- Always ensure that excess grease and oil accumulation, including spillage, is cleaned up immediately.
- Inspect the bale wagon daily for potential fire hazards and make any necessary repairs immediately.
- Check all the electrical wiring and connections for defects, and repair or replace as necessary. Keep battery terminals clean and tight.
- Never perform welding operations until the entire machine has undergone a thorough cleaning. In addition, cover rubber hoses, disconnect the bat-



tery, and have at least a fire extinguisher at hand.

- Hydraulic fluid is flammable. Do not weld on or near pipes, tubes, or hoses that are filled with fluid. Do not smoke when checking or filling the tank. Keep open flames and sparks away from the bale wagon.
- Hay dust is combustible. Do not have an open flame or weld in dusty environments.
- Maintain the engine cooling system to avoid overheating.
- Remember, there is always a risk of fire.

## Fire Fighting Equipment

- It is recommended to carry an "ABC" fire extinguisher on the bale wagon or in the pull vehicle at all times. Install it within easy reach of the operator in a position that protects it from damage. Use only a "quick release" type of mount. It is also recommended to carry a four gallon water container with a pump, or as required by local and state law.
- Keep your fire extinguisher(s) fully charged and in good working order. Know how to use them.
- Read and understand the instructions printed on the canisters and learn how to operate them. Learn how to remove the canisters from their mounting brackets in the shortest amount of time.
- Service the extinguisher according to the manufacturer's specifications. Service after every use, no matter how short a time.

## Fire Suppression

- Do not panic. At the first sign of trouble (burning smell, smoke, visible flame, etc), stop the tractor and turn off the engine in the clearest area available, with the tractor upwind from the bale wagon if possible.
- If the fire cannot be extinguished safely, immediately evacuate the area. DO NOT attempt to extinguish it. DO NOT risk personal injury. Contact your local fire department.
- If you have determined that the fire may be safely extinguished, use the fire extinguisher according to the manufacturer's instructions, or use the water pump, aiming water at the base of the fire.
- When the bale wagon has fully cooled, thoroughly inspect, and make all necessary repairs to return the bale wagon to normal operation.
- Recharge or replace the fire extinguishers before returning to work.

<b>BOLT TORQUE - GRADE 8 COARSE THREAD</b>				
<b>BOLT size-pitch</b>	<b>LUBRICATED</b>		<b>NEVER-SEIZE</b>	
1/4"-20	129	in-lbs	86	in-lbs
5/16"-18	23	ft-lbs	15	ft-lbs
3/8"-16	40	ft-lbs	27	ft-lbs
7/16"-14	63	ft-lbs	42	ft-lbs
1/2"-13	96	ft-lbs	64	ft-lbs
9/16"-12	140	ft-lbs	93	ft-lbs
5/8"-11	195	ft-lbs	130	ft-lbs
3/4"-10	340	ft-lbs	230	ft-lbs
7/8"-9	550	ft-lbs	365	ft-lbs
1"-8	820	ft-lbs	550	ft-lbs
1 1/8"-7	1,160	ft-lbs	775	ft-lbs
1 1/4"-7	1,640	ft-lbs	1,100	ft-lbs
1 3/8"-6	2,150	ft-lbs	1,430	ft-lbs
1 1/2"-6	2,850	ft-lbs	1,900	ft-lbs
1 3/4"-5	4,490	ft-lbs	3,000	ft-lbs
2"-4.5	6,750	ft-lbs	4,500	ft-lbs
2 1/4"-4.5	9,870	ft-lbs	6,580	ft-lbs
2 1/2"-4	13,500	ft-lbs	9,000	ft-lbs
2 3/4"-4	18,400	ft-lbs	12,300	ft-lbs
3"-4	24,200	ft-lbs	16,200	ft-lbs



## Table of Contents

<b>BALE WAGON SERIAL NUMBER .....</b>	<b>2</b>
<b>SAFETY .....</b>	<b>3</b>
<b>TABLE OF CONTENTS .....</b>	<b>9</b>
<b>7000 BALE WAGON OVERVIEW .....</b>	<b>10</b>
<b>LUBRICATION / SERVICE SCHEDULE.....</b>	<b>11</b>
<b>FIELD START-UP PROCEDURES .....</b>	<b>12</b>
<b>TIE TIER CAM INSTALLATION .....</b>	<b>14</b>
<b>LOAD BED ADJUSTMENT .....</b>	<b>16</b>
<b>TRACTOR CONTROL BOX.....</b>	<b>18</b>
<b>OPERATING INSTRUCTIONS.....</b>	<b>20</b>
<b>OPERATING TIPS.....</b>	<b>23</b>
<b>LIMIT SWITCH FUNCTIONS .....</b>	<b>24</b>
<b>LIMIT SWITCH LOCATIONS .....</b>	<b>25</b>
<b>TIER SEQUENCE OF OPERATION .....</b>	<b>26</b>
<b>BALE TIER STACK PATTERNS .....</b>	<b>28</b>
<b>SOLENOID VALVE DIAGNOSTICS .....</b>	<b>29</b>
<b>LIMIT SWITCH DIAGNOSTICS .....</b>	<b>30</b>
<b>OVER CYCLE TIME DIAGNOSTICS .....</b>	<b>32</b>
<b>LIMIT SWITCH SETUP AND ADJUSTMENTS .....</b>	<b>34</b>
<b>HYDRAULIC SYSTEM VALVE SETTING PROCEDURE .....</b>	<b>42</b>
<b>TROUBLESHOOTING .....</b>	<b>45</b>
<b>XA2 MODULE .....</b>	<b>52</b>
<b>MC2 MODULE .....</b>	<b>53</b>
<b>PROGRAM FLOW CHART .....</b>	<b>55</b>

# 7000 Bale Wagon Overview

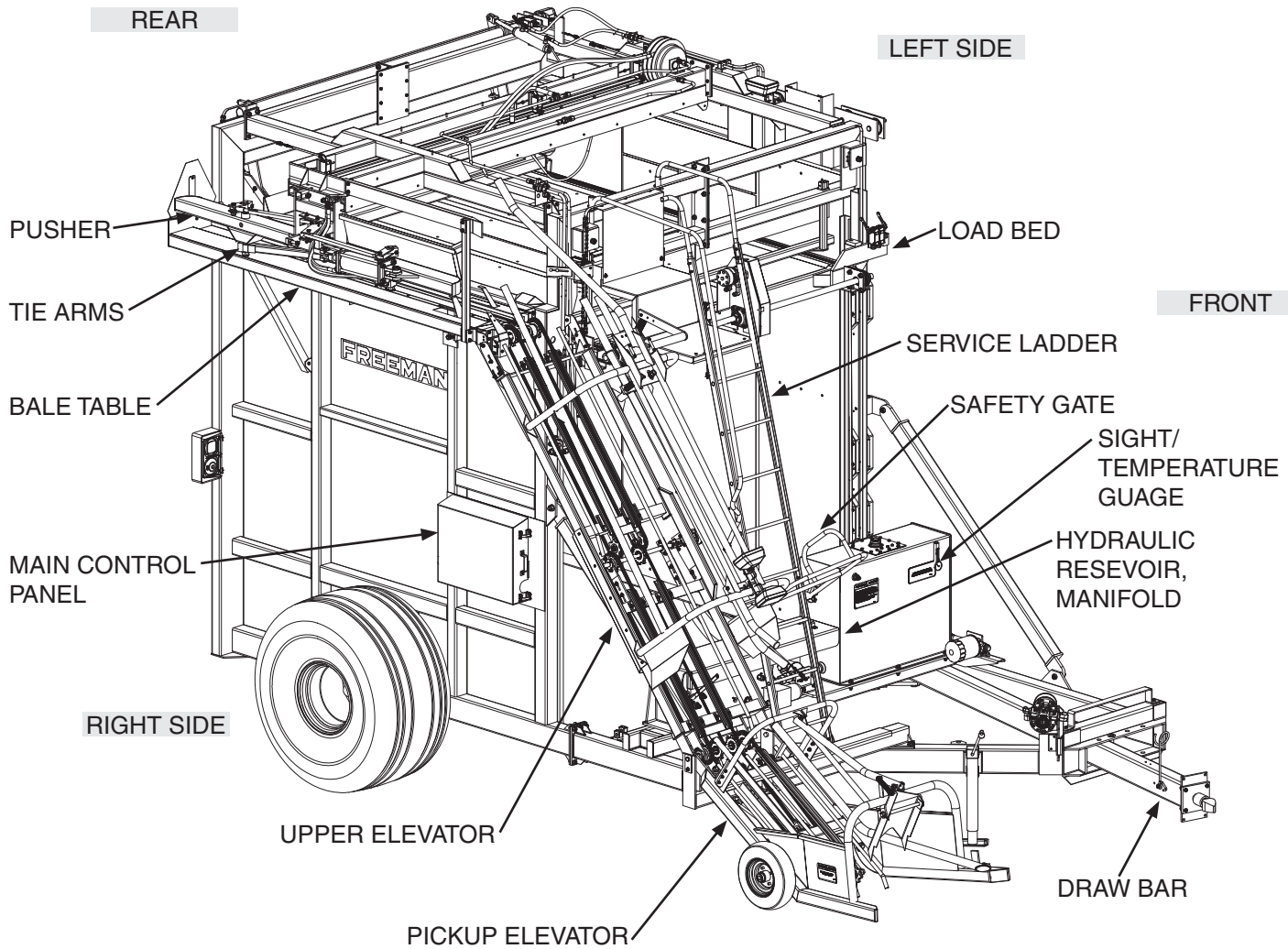

Figure 1 - 7000 Bale Wagon Layout

The model 7000 bale wagon is designed to collect, mechanically load, and position bales into a tight square stack. The finished stack is normally 9.3 feet (283 cm) high and 8 feet (244 cm) square. These dimensions make it ideal for transporting by truck.

The bale wagon can stack 14", 15", or 16" bales that are square, solid and 45" to 48" (114 cm to 123 cm) long. Bales must be flat, with twine running on top and bottom of the bale.

# Lubrication / Service Schedule

*Only through timely service, maintenance and making the proper adjustments can you realize the optimum performance and long life from this equipment. Follow these recommended service checks at their suggested intervals to maximize the bale wagon's performance and service life.*

## WARNING

Always disengage PTO and shut off power when inspecting, adjusting, lubricating, or servicing the bale wagon.

### HYDRAULIC OIL:

Hydraulic Oil: Mobil 424 or Mobil DTE 15M or equivalent to a Viscosity greater than 10 centistokes at 180°F (82°C) and less than 200 centistokes at 60°F (15°C).

- Clean around the fill area with compressed air before opening the fill port.
- Use only NEW oil when refilling oil tank.
- Oil must be filtered 10 micron or less before entering the tank.
- Oil must meet cleanliness standard ISO 4406:1999, 19/17/14 (4 µm / 6 µm / 14 µm).
- Fill to the full mark on the oil tank site gauge with all cylinders fully retracted.

### GREASE FITTINGS:

Multi-purpose Lithium base #2, EP grease.

Allied Part Number: LBR0000099

CHAIN TENSION		
CHAIN LOCATION	ALLOWABLE SLACK	CHECK
Pickup Elevator	1" - 2.5" (2.54 - 6.25 cm)	Weekly
Upper Elevator	1" - 2.5" (2.54 - 6.25 cm)	Weekly
Bale Table	1" - 2.5" (2.54 - 6.25 cm)	Weekly
Load Bed Push Off	Less Than 1" (2.54 cm)	Daily
Load Bed Lift	*Constant Tension	Weekly

\*Front and rear load bed lift chains need to be equalized to maintain the load bed level under all circumstances. See "Load Bed Adjustment" on page 16

### CHECK / SERVICE EVERY 4 HOURS:

- Check hydraulic tank fluid level

### CHECK / SERVICE DAILY:

- Blow bale wagon clean with compressed air (**Do not steam clean**)
- Lift cover & blow Hydraulic Manifold clean to remove water & debris from around valves
- Lubricate ball hitch
- Check system hydraulic oil level

### CHECK / SERVICE EVERY 80 HOURS:

- Check tire inflation - 36 psi (250 kPa) at 30 MPH (50 kph) Maximum speed
- Check wheel fasteners for proper torque

### CHECK / SERVICE EVERY 150 HOURS:

- Change main hydraulic filter

### CHECK / SERVICE ANNUALLY:

- Change system hydraulic oil
- Change oil tank filters (or as indicated by condition)
- Repack wheel bearings

### SERVICE EVERY 2 YEARS:

- Remove and replace oxidation inhibitor in electrical junction box and tractor control box

# Field Start-Up Procedures

## PREPARATION:

### CONNECTING BALE WAGON

1. Remove Crowder Bar if stacking 3 tie bales. The Crowder Bar is for 2 tie bales only (see Figure 2 and Figure 3).

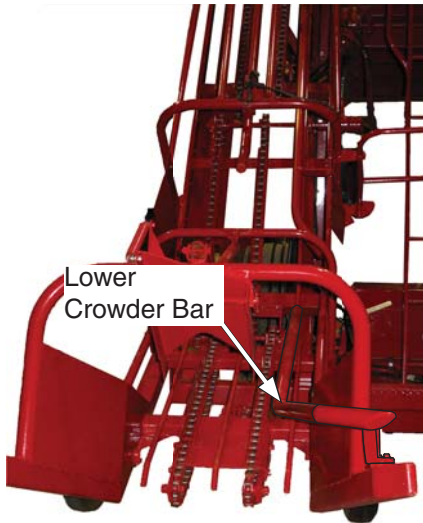

Figure 2 - Lower Crowder Bar



Figure 3 - Upper Crowder Bar



## WARNING

**Make Certain that everyone is clear of the bale wagon before starting engine or engaging P.T.O. clutch.**

2. Connect 2 5/16" ball to tractor draw bar and torque nut to 920 ft-lbs.
3. The center of the ball should be approximately 16" from the end of the tractor P.T.O. shaft. The top of the ball should be 19 1/2" from the ground (see Figure 4).

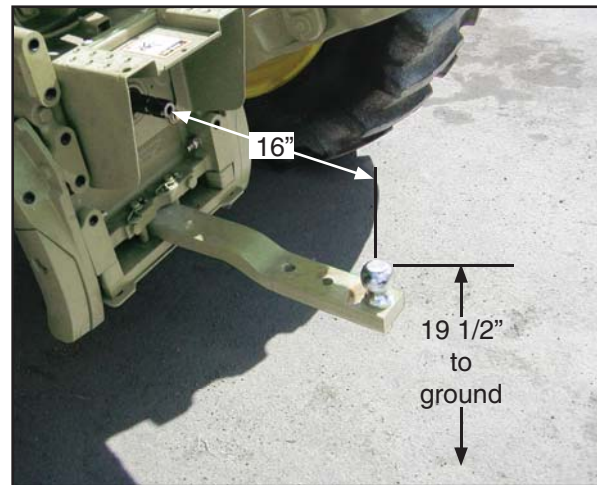

Figure 4 - 2 5/16" Tractor Ball

4. With the bale wagon on a level surface, place a level on top of the hitch assembly and adjust the draw bar jack up or down until it is level.
5. Adjust the hitch up or down so that it is even with the ball (loosen and re-tighten the nuts and bolts, torque nuts to 75 ft-lbs) (see Figure 5).

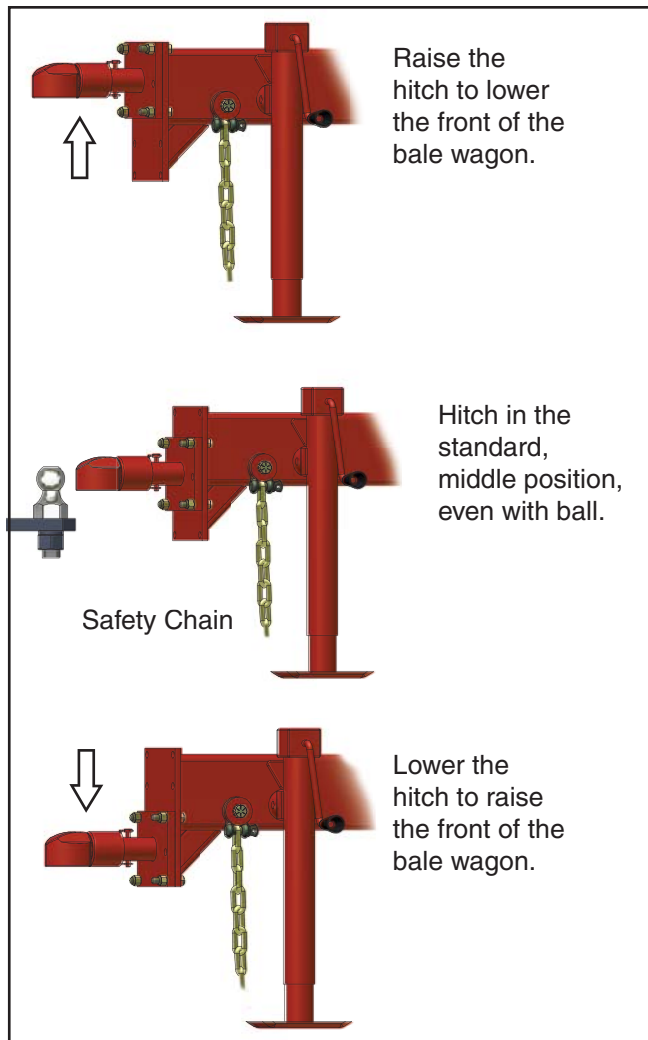
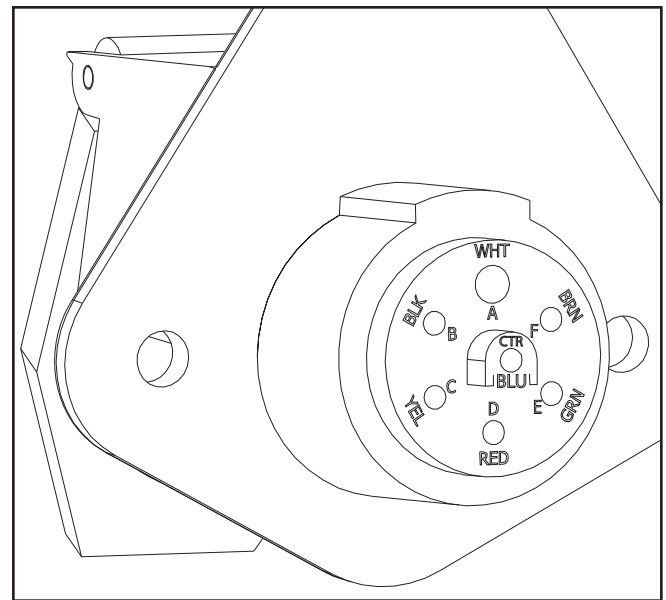

Figure 5 - 2 15/16" Tractor Ball

6. Connect hitch to tractor ball.
7. Secure draw bar drag chain to tractor.
8. Connect 7 pole cable between tractor and bale wagon (see Figure 6).
9. Connect hydraulic pump to the tractor PTO shaft. Make sure that the torque chain is connected to the draw bar as to eliminate movement of the pump when the PTO is engaged.
10. Connect the white power supply wire to a 12 volt power source (typically the positive terminal of the tractor battery) and the black ground wire to a sufficient ground.



Rear View of Highway Light Connector

PIN	WIRE/GA.	Function
A	WHT 12	Ground
B		Not Used
C	YEL 16	Left Turn
D	RED 16	Brake Lights
E	GRN 16	Right Turn
F	BRN 16	Tail Lights
G (CTR)		Not Used

Figure 6 - Male 7 Pole Connector on Draw Bar

11. Connect the Highway Lights cord (see Figure 6).
12. Mount the tractor control box to a convenient location on the tractor. Carefully route and secure the cable with enough slack so as not to pull or bind but tight enough to not get caught or pinched by any part of the bale wagon or tractor.
13. The tractor control box has two options for connecting the communication cable, one on the bottom and another on the back of the control box. Use the one that works best for your mounting location.

# Tie Tier Cam Installation

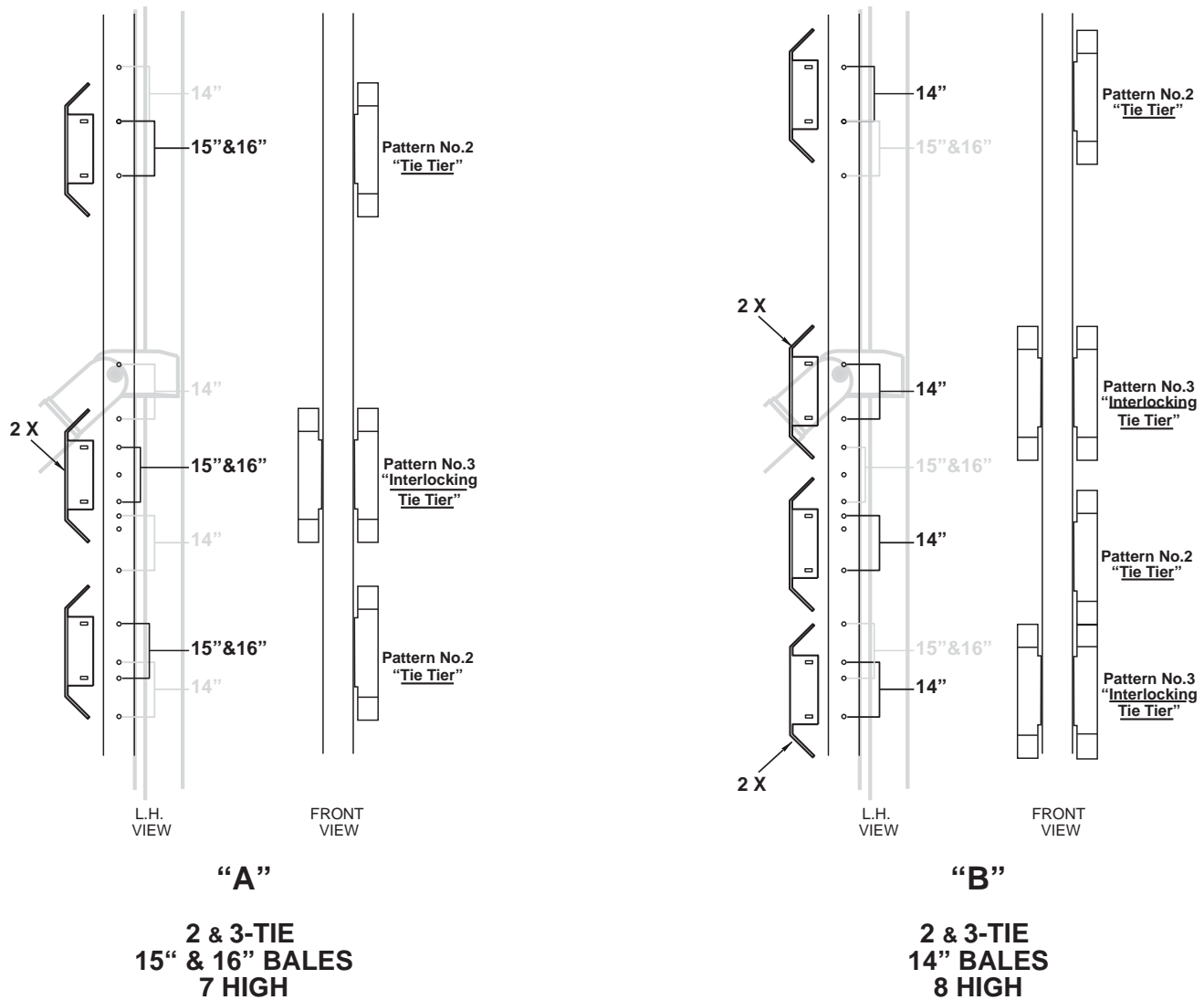

Figure 7 - Tie Tier Cam Installation

## TIE TIER CAM ADJUSTMENT: STACKING 14", 15", OR 16" HIGH BALES

To properly stack bales of different heights, it is necessary to reposition the Tie Tier activating cams. These cams activate limit switches LS-5 and LS-6 that communicate the position of the load bed to the Control Circuit. The Control Circuit then determines which tie sequence should occur. See Figure 7 for the location of the Tie Tier Activating Cams.

To stack 15" or 16" high bales instead of 14" high bales, the Tie Tier activating cams must be adjusted. Each cam must be positioned to correspond to the proper tier.

Tie Tiers may be added by installing additional cams.

**INTENTIONALLY LEFT BLANK**

# Load Bed Adjustment

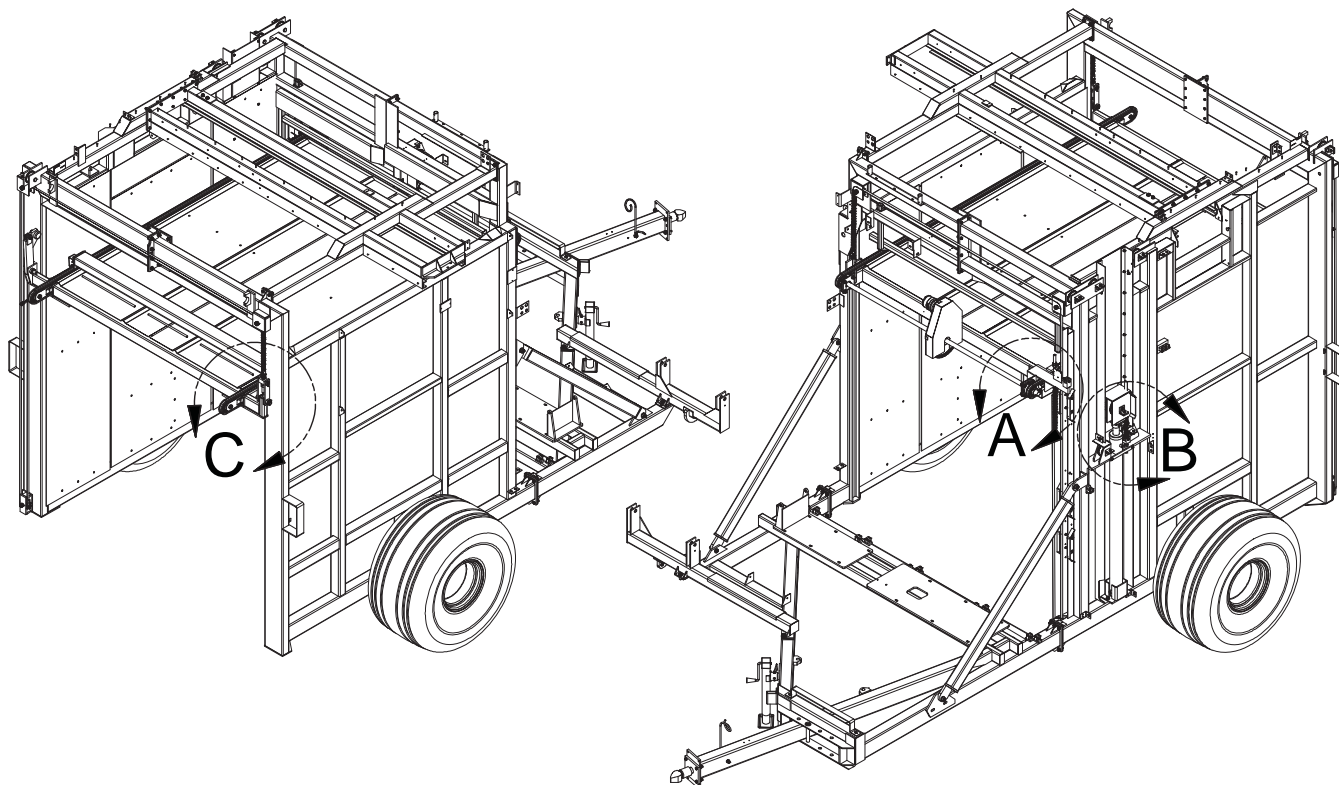

Figure 8 - Load Bed Angle Adjustment

## NOTICE

Be sure that the chain does not twist when making adjustments.

### Adjusting Load Bed Height

When the load bed is in the fully raised position, it must be 1" to 2" (25mm - 50mm) below the top of the bale table. Always check this distance when initially setting up the bale wagon and/or after making adjustments to the load bed angles. Minor adjustments may be made to the overall height by evenly moving the front and rear height adjustment bolts (see Figure 9).

### Adjusting Load Bed Angle, Front to Back

Use the chain length adjusting bolts located on the left side of the machine, at the midpoint of the load bed lifting cylinder (see Figure 8, Detail B).

### Raising the front of the load bed:

Loosen the top adjuster nut on the rear chain mount and tighten the bottom nut as required to shorten the chain (see Figure 9). When the adjustment is correct, tighten the top nut to lock the adjuster in place.

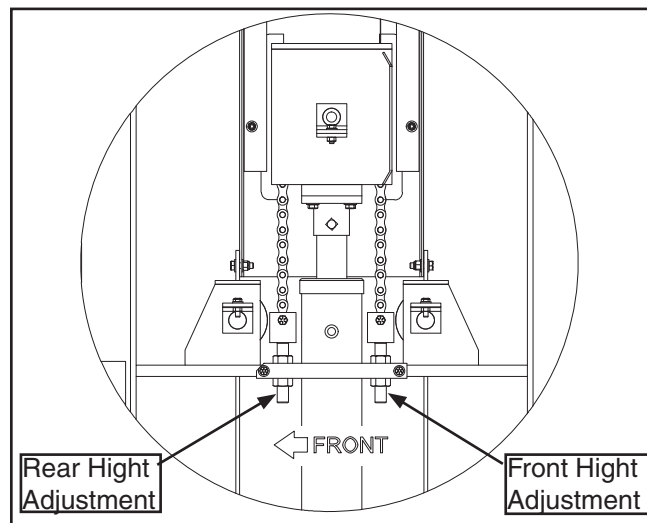

Figure 9 - View B, Front/Back Load Bed Angle



## Lowering the front of the load bed:

Loosen the bottom adjuster nut on the rear chain mount as required to lengthen the chain (see Figure 9). When the adjustment is correct, tighten the top nut to lock the adjuster in place.

## Raising the rear of the load bed:

Loosen the top adjuster nut on the front chain mount and tighten the bottom nut as required to shorten the chain (see Figure 9). When the adjustment is correct, tighten the top nut to lock the adjuster in place.

## Lowering the rear of the load bed:

Loosen the bottom adjuster nut on the front chain mount as required to lengthen the chain (see Figure 9). When the adjustment is correct, tighten the top nut to lock the adjuster in place.

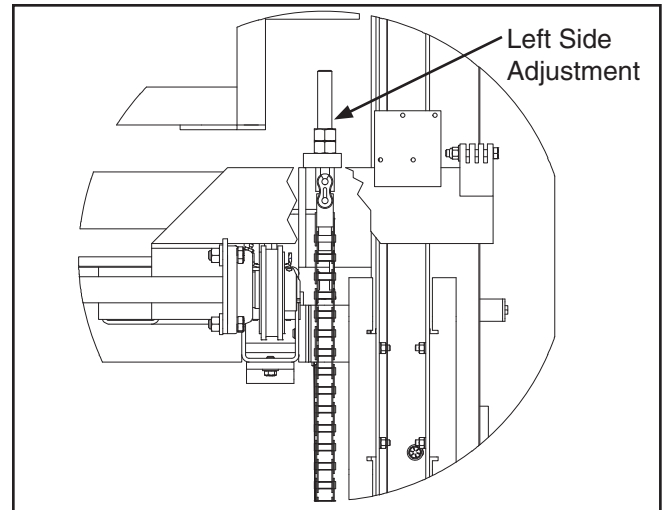

Figure 10 - View A, Left Load Bed Height

## Adjusting Load Bed Angle, Side to Side

Use the chain length adjusting bolts located on the front, left side of the load bed (see Figure 8, Detail A) and at the rear right side of the load bed (see Figure 8, Detail C).

Adjust the tension in the chain to level the load bed. Adjust the front and rear load bed chains evenly (see Figure 10 and Figure 11).

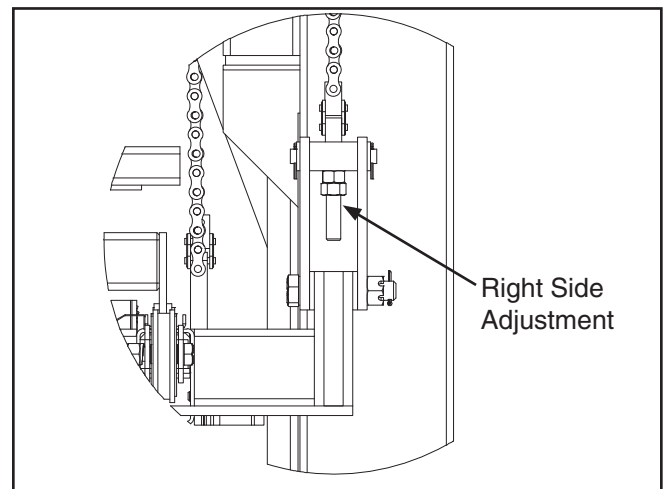

Figure 11 - View C, Right Load Bed Height

# Tractor Control Box

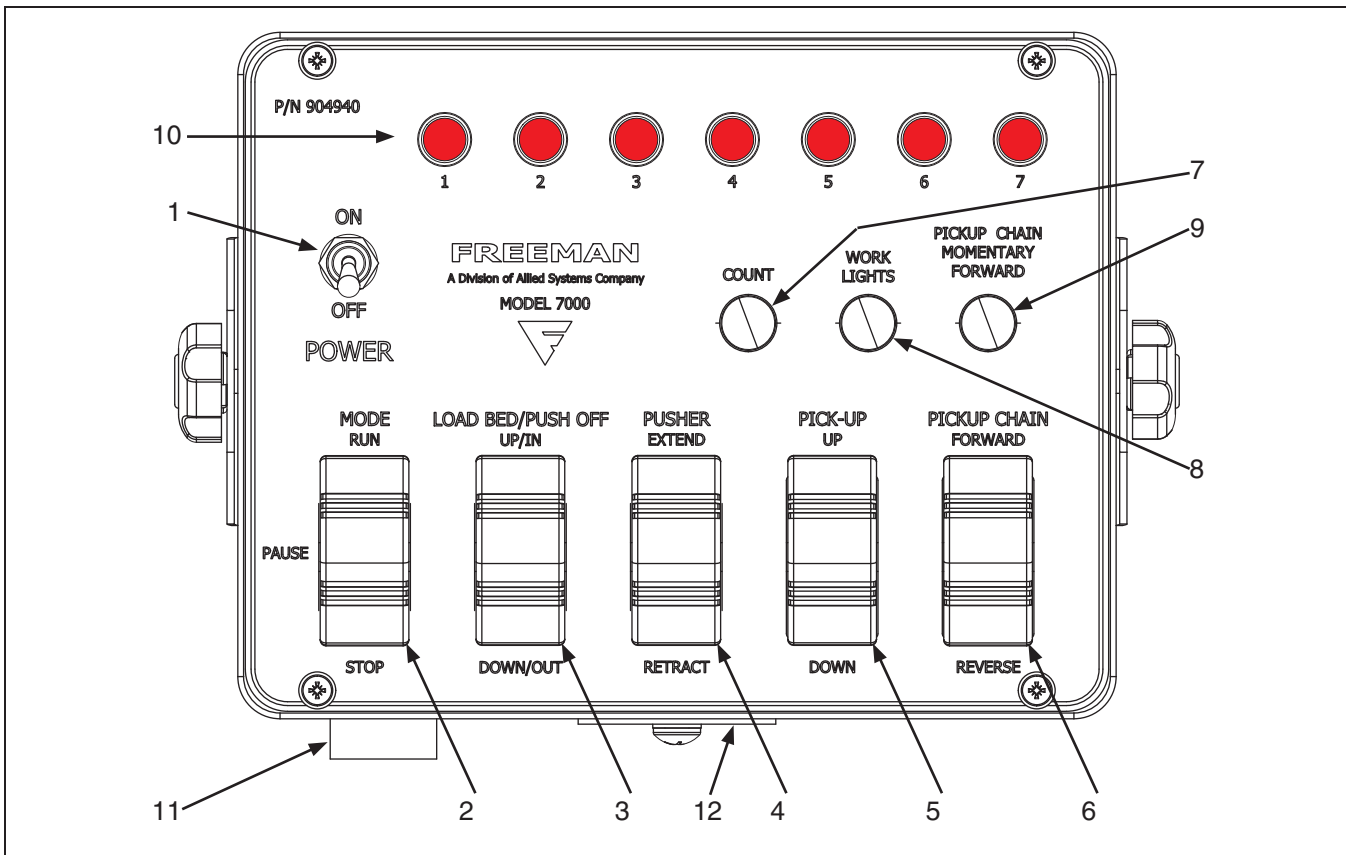

Figure 12 - Tractor Control Box

## 1. POWER

- **ON** - Turns on Tractor Control Box as well as the main power relay to the entire bale wagon, including Work Lights.
- **OFF** - Turns off Tractor Control Box as well as power to the entire bale wagon, including Work Lights. The Count will be reset when Power is turned Off.

## 2. MODE

- **RUN** - Activates the Auto Stacking mode.
- **PAUSE** - Stops all automatic functions. Program settings can be adjusted while in the Pause position.
- **STOP** - Stops all commands from the controller to the valves.



The **STOP** position stops all commands from the controller to the valves, but does **NOT** immediately stop all movement. Hydraulic cylinders and motors may continue to move until stopped by friction, gravity or obstructions.

## 3. LOAD BED/PUSH OFF

- **UP/IN** - Will bring the Push Off bar in to the stacking position (front of the Load Bed), then will raise the Load Bed until it reaches the top of the bale wagon.
- **DOWN/OUT** - Will lower the Load Bed until it reaches the bottom position, then will extend the Push Off Bar to the back of the Load Bed.

#### 4. **PUSHER**

- **EXTEND** - Will extend the Pusher toward the left side of the bale wagon.
- **RETRACT** - Will retract the Pusher toward the right side of the bale wagon (bale table).

#### 5. **PICK-UP**

- **UP** - Raises the pickup chute
- **DOWN** - Lowers the pickup chute

#### 6. **PICKUP CHAIN**

- **FORWARD** - Directs the pickup elevator chain to raise bales to the upper elevator.
- **REVERSE** - Directs the pickup elevator chain to lower the bale and push it back towards the field.

#### 7. **COUNT**

- Push to advance through each of the steps of the current stack pattern. The Indicator Lights (10) will illuminate to show which step the machine has finished for the current tier.

#### 8. **WORK LIGHTS**

- Push the button to turn the work lights on or off.

#### 9. **PICKUP CHAIN MOMENTARY FORWARD**

- Runs the pickup elevator chain forward as long as the button is depressed.

#### 10. **INDICATOR LIGHTS**

- Multifunction indicator lights. Illuminate to indicate stacking sequence, trouble shooting, function mode.

#### 11. **BUZZER**

- Audible buzzer will sound when the Load Bed is fully lowered. The intensity of the buzzer can be adjusted from the front of the buzzer.

#### 12. **REMOTE CONTROL CONNECTOR**

- There are two connection points to provide multiple mounting options. One located on the bottom of the control box and one located on the back of the control box.

# Operating Instructions



## WARNING

Make certain everyone is clear of the bale wagon before starting engine operation.

The bale wagon was designed to collect, mechanically load, and position bales into a tight square stack. Stacks can be 7 tiers high with 15" (38 cm) and 16" (40.5 cm) bales, or 8 tiers high with 14" (35.5 cm) bales. The stack is normally 9.3 feet (283 cm) high and 8 feet (244 cm) square. These dimensions make it ideal for transporting by truck.

Bales to be stacked must be square, solid and 45" to 48" (114 cm to 123 cm) long. Bales must be flat, with twine running on top and bottom of the bale.

### SETTING BALE SIZE

1. Locate the switch inside the Junction Box (see Figure 13).
2. Put the switch in the proper location, either 2-tie or 3-tie depending on the size of the bale you will be picking up.

### START UP

(See Figure 12 on page 18 for switch locations.)

1. Check the hydraulic fluid level on the sight gauge.
2. Check that the MODE switch is in the STOP position and the PICKUP CHAIN switch is in the middle (stop) position.
3. Start the Tractor following all the Manufacturers procedures.

**Note: The Bale Wagon should be started with the Mode switch in the "Stop" position. If the machine is started with the Mode switch in the "Run" position or the "Pause" position none of the hydraulic functions will work until the Mode switch is first set back to the "Stop" position.**



## WARNING

The Pickup Chain switch can be latched in the FORWARD position. If the Mode switch is switched to the "Pause" position and there is hydraulic energy in the system, the Pickup Chain will run. It is recommended to place this switch in the bottom (Stop) position when starting the machine (see Figure 12 on page 18).

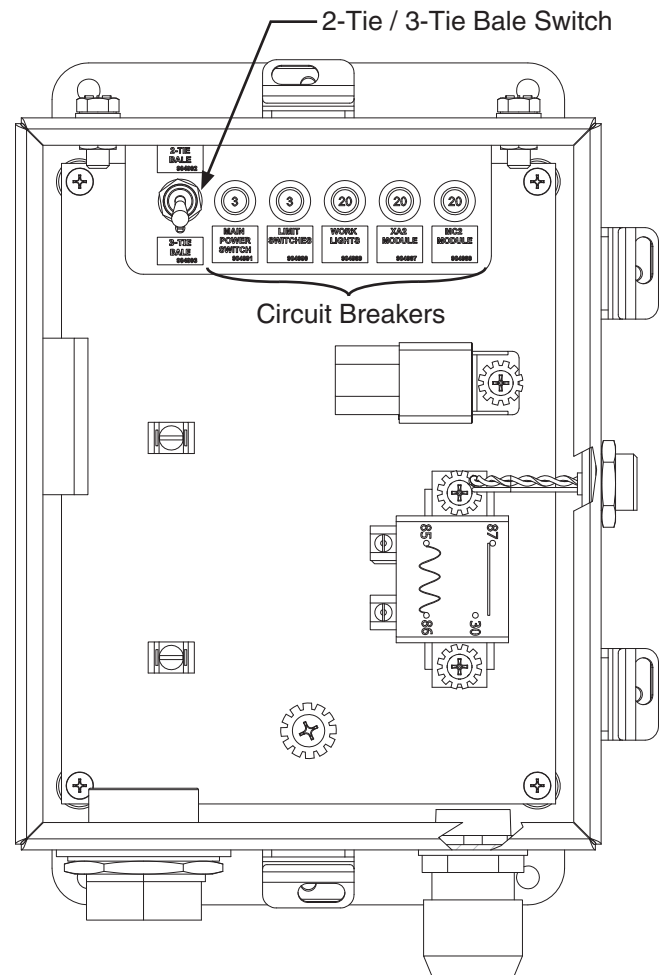

Figure 13 - Junction Box

4. Place the POWER switch in the ON position.
5. Engage the hydraulic PTO and slowly bring the PTO rpm up to 540 rpm.
6. Bring hydraulic oil to recommended operating temperature of 80°F (27°C) to 180°F (82°C) as shown on the level/temperature gauge on the front of the Hydraulic tank.
7. Verify that the Load Bed and pusher are in the proper location. Adjust their position with the Mode switch in the PAUSE position using the manual switches (see "Manual Operation:" on page 22).
8. Once the setup of the machine and the position of the hydraulic actuators are in the correct position, the machine can now be put into the "Run" mode. Refer to "RUNNING THE BALE WAGON" on page 21 for more information.

## SHUT DOWN

1. Disengage the tractor PTO.
2. On the Tractor Control Box, put the MODE switch in the “STOP” position.
3. Place the PICKUP CHAIN switch in the middle (stop) position.
4. Turn the POWER switch to OFF.
5. Turn the tractors ignition switch OFF.

## RUNNING THE BALE WAGON

1. When the machine is ready to pick up bales, the MODE switch should be put into the RUN position. The Bale Table chain will begin to rotate.
2. Set the PICKUP CHAIN switch to FORWARD. The Pickup Chain will now start to rotate.
3. Depending on which tier and bale size the machine is set to it will determine the appropriate sequence of operations that will be undertaken and the number of appropriate bales to place onto the Bale Table. Refer to “Tier Sequence of Operation” on page 26 for specifics on the sequence and appropriate number of bales.

## UNLOADING

**NOTE: Refer to “Limit Switch Locations” on page 25.**

1. The Load Bed Buzzer, located on the Tractor Control Box will make a continuous sound for 8 seconds when the Load Bed has reached LS-12. This indicates when the Load Bed is full (at its lowest position) and is ready to start unloading.
2. Place the MODE switch in the STOP position. Place the PICKUP CHAIN in the middle (off) position. Raise the PICK-UP. Disengage the PTO. Drive to the unloading area.
3. Back the bale wagon into position.
4. Engage the brakes and the place the tractor in neutral. Engage the PTO.
5. Place the MODE switch in the PAUSE position.

6. To continue the unloading process hold down the Load Bed/Push Off switch in the Down/Out position. This will allow the Load Bed Cylinder to continue to retract setting the rear portion of the Load Bed onto the ground. When the Load Bed cylinder is fully retracted, the Bale Retainer will lift up and actuate LS-10. Once LS-10 is actuated the Load Bed/Push Off switch will control the Push Off Bar.

**Note: If desired, adjust the tractor PTO speed to 50% or less of full PTO rpm. This will reduce the speed of the PTO and therefore the speed of the hydraulic system which will allow for easier control of the Push Off Bar and the depositing of the stack.**

7. Once LS-10 is actuated continue to hold the Load Bed/Push Off switch in the Down/Out position and the Push Off bar will begin to push the stack out, off of the Load Bed until the Push Off bar activates LS-15.
8. As the stack is pushed off the Load Bed by the Push Off Bar, the tractor may be allowed to roll forward to accurately place the stack. Technique will vary and practice will make this process smoother.
9. Once the Push Off Bar actuates LS-15 it will no longer travel in the Down/Out direction for 5 seconds but is allowed to be actuated in the Up/In direction immediately.

## NOTICE

*Although the Push Off Bar can be actuated Down/Out direction after 5 seconds, it is not recommended as the Push Off Bar can exceed the travel of the machine and could cause damage to the Push Off Bar or the Chain if it goes beyond the activation point of LS-15.*

10. Once the stack is off of the Load Bed, hold the LOAD BED/PUSH OFF switch in the UP/IN position to bring the Push Off bar to the front of the Load Bed. While continuing to hold the switch in the UP/IN position, when the Push Off bar reaches the front of the Load Bed, the Load Bed will begin to raise. Release the UP/IN switch when the Load Bed gets to the top of its travel and is ready to receive the first tier of bales.
11. It is recommended that the control box be turned off and the PTO be disengaged before traveling back to the field to pick up more bales.

---

## **MANUAL OPERATION:**

Several functions on the bale wagon can be manually operated. The following items can be manually operated from the tractor control box while the MODE switch is in RUN or PAUSE position.

- LOAD BED / PUSH OFF
- PICK-UP
- PICKUP CHAIN
- PICKUP CHAIN MOMENTARY FORWARD
- WORK LIGHTS

The following functions can only be operated when the MODE switch is in the PAUSE position.

- PUSHER
- COUNT

## Operating Tips



### WARNING

**Always disengage PTO and shut off power when inspecting, adjusting, lubricating, or servicing the bale wagon.**

#### OPERATION TIPS:

1. Watch the Pickup Elevator and be sure bales do not hang or jam.
2. Each time the Load bed lowers to receive the next tier, visually check to see that it is positioned correctly.
3. Count the number of bales entering the bale table for each tier and keep track of the sequence. The more the operator is aware of the steps that are taking place and about to happen, the more efficient the process will be.
4. While the pusher is positioning bales on the load bed, the upper elevator chain and the table chain do not operate. The pickup chain can continue to operate since it is controlled by the operator. The PICKUP control switch on the tractor control box will start and stop the pickup chain. While waiting for the pusher to return to the home position, a bale can be loaded into the pickup then the PICKUP chain stopped to hold the bale on the pickup and prevent bale damage or twine breakage. Greater stacking efficiency will be realized if bales are always ready to enter the upper elevator.
5. As steps 3-7 of pattern No. 2 and steps 3-5 of pattern No. 3 are being formed, it will be necessary for the operator to allow only one bale at a time on the upper elevator waiting to enter the bale table. During these steps, one bale is placed on the center of the bale table, then pushed into the center of the tier on each pusher stroke. If two bales are allowed on the upper elevator before a single bale push, the second bale can get in the way of the pusher as it pushes the first bale onto the load bed. Use the pickup control switch to start and stop the pickup chain to keep only one bale on the upper elevator and one bale on the pickup during these steps (See "Tier Sequence of Operation" on page 26).
6. Operators learning to use the bale wagon should select a ground speed that allows plenty of time for the stacking functions to occur. Always operate the machine in a safe and cautious manner.
7. Count the bales that will form the last tier of the stack. Stop picking up bales as the 10th bale enters the pickup for 2 tie bales, or as the eighth bale enters the pickup for 3 tie bales. This will be the last bale of the load.
8. When moving from the field to the unloading area or from field to field be sure there is sufficient overhead clearance for the Bale Wagon.
9. To change the tier count (for example, if a bale breaks when pushed onto the load bed and that step needs to be repeated) use the Count button to access the correct step (see "Tractor Control Box" on page 18).
  - A. Place the Mode button in the Stop position.
  - B. Turn the Power switch OFF.
  - C. Stop the PTO and turn the tractor off.
  - D. Clear any obstructions on the Bale Wagon.
  - E. After all personnel are clear of the Bale Wagon, follow the procedure for "START UP" on page 20.
  - F. Place the Mode Switch in the Pause position.
  - G. Press the Count button until the Indicator Lights are on the correct step.
  - H. Place the Mode switch back in the Run position.
  - I. Continue to load the Bale Wagon.

---

# Limit Switch Functions

**NOTE: See “Figure 14 - Limit Switch Locations” on page 25**

**LS-1** Limit switch 1 is located near the center of the bale table. If a standard tier is being formed LS-1 operates in conjunction with LS-8 to activate the pusher. When the center bales of a tie tier are being positioned, LS-1 alone can activate the pusher. LS-1 can be moved forward or back to affect the position of the center bale in a tie tier.

**LS-2** Limit switch 2 is located at the top left of the machine near the rear pusher track. This switch is operated by the pusher frame as it extends and signals the pusher to return to its home position. LS-2 signals the pusher to return when a long stroke is required during a tie cycle.

**LS-3** Limit switch 3 is located at the top center of the machine near the rear pusher track. This switch is operated by the pusher frame as it extends and signals the pusher to return to its home position. LS-3 signals the pusher to return when a short stroke is required.

**LS-4** Limit switch 4 is located at the top right of the machine, over the bale table, near the rear pusher track. This switch is operated by the pusher frame as it returns and signals the pusher to stop in its home position.

**LS-5** Limit switch 5 is located at the left front of the load bed. This switch, along with LS-6, senses the load bed cams to determine the load bed position and the proper stack pattern.

**LS-6** Limit switch 6 is located at the left front of the load bed. This switch, along with LS-5, senses the load bed cams to determine the load bed position and the proper stack pattern.

**LS-7** Limit switch 7 is located on the rear of the top center beam. LS-7 is operated by the index paddle. When operated LS-7 signals how far to lower the bed.

**LS-8** Limit switch 8 is located near the front of the bale table. It is operated when the second bale enters the bale table. On pattern #1, LS-8 and LS-1 operated together allow the pusher to extend.

**LS-9** Limit switch 9 is located on the right hand side of the machine at the top of the bale elevator. LS-9 works the same as LS-14 to prevent the pusher from operating until a bale has entered the bale table area.

**LS-10** Limit switch 10 is located on the left rear at the top of the machine. LS-10 is operated by the bale retainer as it opens when the load bed is lowered to unload a stack. When LS-10 is operated the control circuit directs power to the load push off bar to push a stack off the load bed.

**LS-11** Limit switch 11 is located at the front center of the load bed. LS-11 is operated by the push off bar as it is returned to the home position. When LS-11 is operated the load bed can be raised from the unload position to load position.

**LS-12** Limit switch 12 is located on the left side of the machine. The switch is operated when the load bed cylinder retracts. LS-12 signals when the load bed is in the top position.

**LS-13** Limit switch 13 is located on the service ladder at the safety gate. LS-13 prevents the machine from being operated with the safety gate open.

**LS-14** Limit switch 14 is located at the top of the bale elevator near the entry to the bale table. LS-14 works the same as LS-9 to prevent the pusher from operating until the bale is completely on the bale table.

**LS-15** Limit switch 15 is located at the left rear of the load bed. This switch is operated by the push off bar as it pushes the stack off the bale table. LS-15 signals the push off bar to stop.

**LS-16** Limit switch 16 is located on the top left side of the machine. The switch is operated when the load bed cylinder extends. LS-16 signals when the load bed is in the bottom position.



# Limit Switch Locations

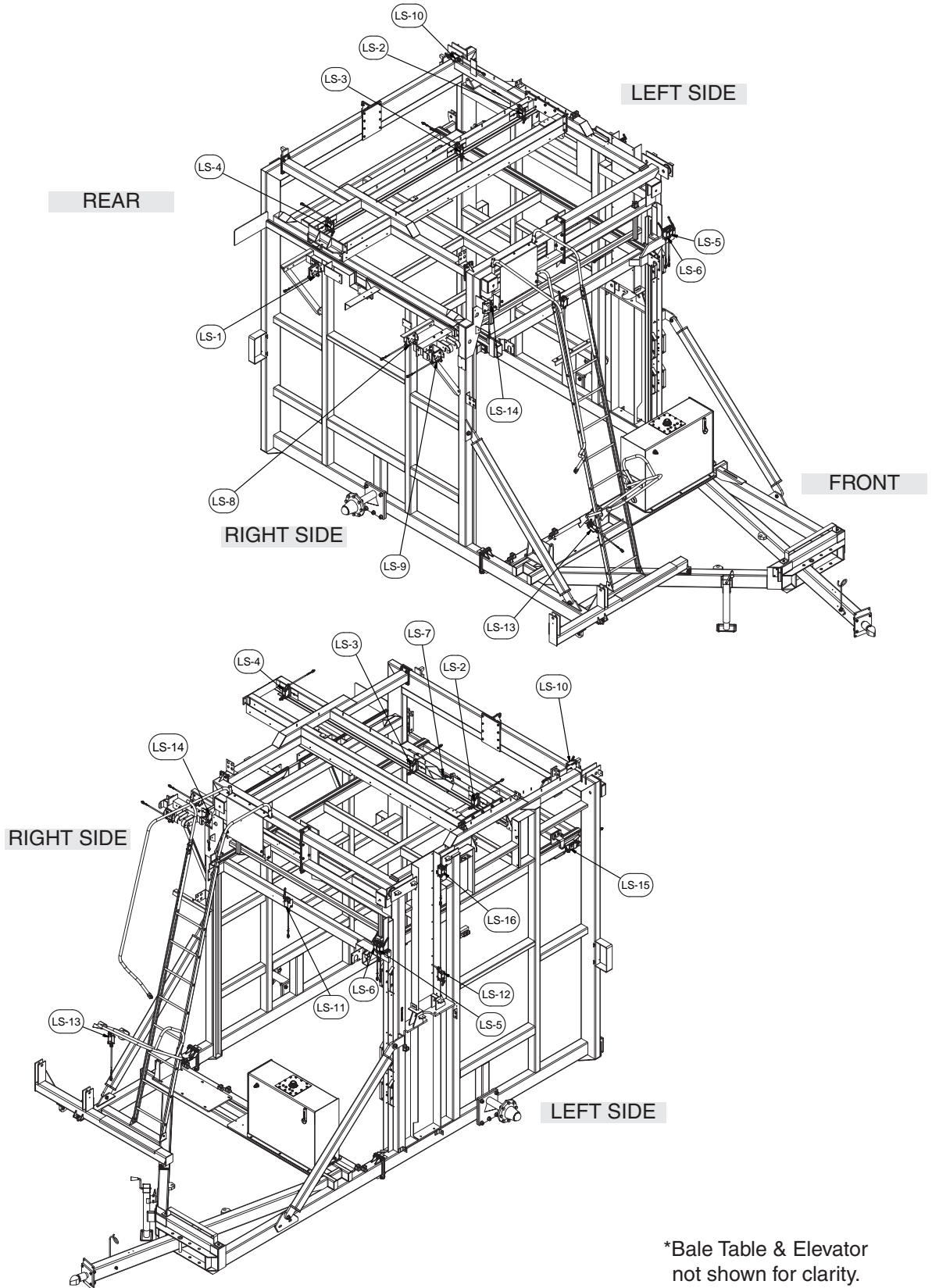

Figure 14 - Limit Switch Locations

# Tier Sequence of Operation

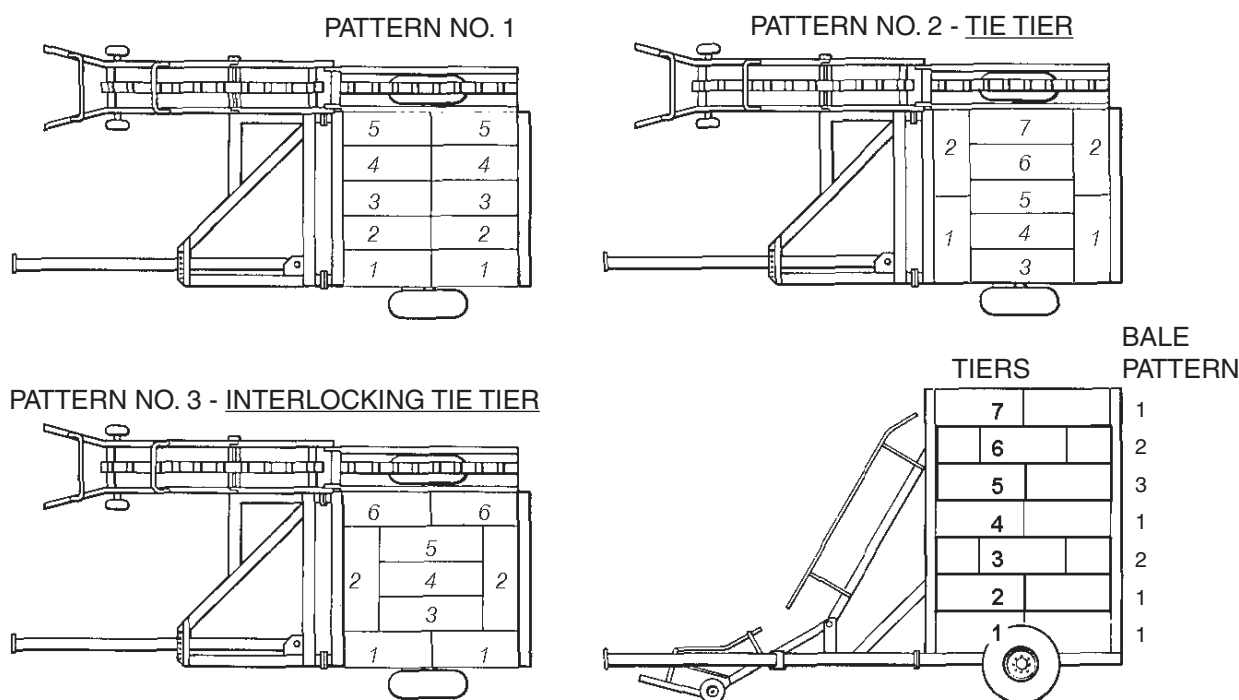

Figure 15 - Bale Order. Note: Order of bales loaded into tiers shown by *Italic numbers*. Illustration shows 16" 2-Tie patterns, for complete Bale Tier Stack Patterns see Figure 17.

## PATTERN NO. 1 - STANDARD TIER

The Standard sequence is activated when LS-5 and LS-6 are both off.

1. Pattern No. 1 begins when two bales enter the upper bale table. When LS-1 & LS-8 are both activated, the pusher extends and the bales are pushed on to the load bed until LS-3 is activated, completing a "pusher short stroke." When the pusher returns and activates LS-4, light No. 1 is lit.
2. This step is repeated for a total of 5 "pusher short strokes." The corresponding lights on the Tractor Control Box turn on after each of the first 4 pusher strokes, indicating the number of completed steps that have occurred.
3. As the last bales are pushed onto the load bed, the index paddle is depressed, triggering LS-7, and the load bed lowers until the paddle is released. All lights on the Tractor Control Box turn off and the next Tier is ready to begin.

Pattern	LS-6	LS-5
1 (Standart Tier)	Off	Off
2 (Standard Tie Tier)	Off	On
3 (Interlocking Tie Tier)	On	On

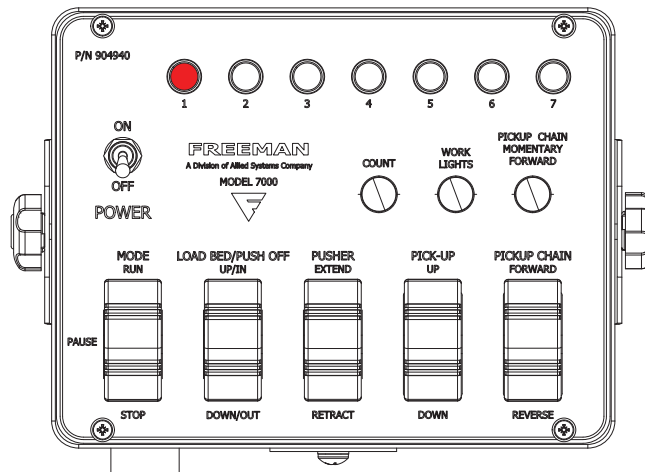

Figure 16 - Tractor Control Box, Tie Tier Sequence Activated

## PATTERN NO. 2 - TIE TIER

The Tie Tier sequence is activated when LS-5 is on, and LS-6 is off.

1. Pattern No. 2 begins when two bales enter the upper bale table. When LS-1 & LS-8 are activated, the pusher is activated. In this tie pattern, a hydraulic valve allows the tie arms to swing out to turn the bales to the outside edge of the load bed. Once the tie arms have extended, the pusher moves the bales to the left hand side of the load bed until LS-2 is activated, completing a "pusher long stroke." The tie arms retract, then the pusher returns and activates LS-4 and light No. 1 is lit.
2. When LS-1 & LS-8 are activated, the pusher is activated. In this tie pattern, a hydraulic valve allows the tie arms to swing out to turn the bales to the outside edge of the load bed. Once the tie arms have extended, the pusher moves the bales to the left hand side of the load bed until LS-3 is activated, completing a "pusher short stroke." The tie arms retract, then the pusher returns and activates LS-4 and light No. 2 is lit.
3. The third step requires only one bale to activate the pusher. When LS-1 is activated, the pusher extends until LS-3 is activated, and this bale is pushed to the center of the bales previously positioned in step 2. Step 3 occurs 5 times. Light No's 3, 4, 5 and 6 illuminate with each step. As the ninth bale (step No. 7) is pushed across onto the load bed the index paddle is depressed, triggering LS-7, and the load bed lowers until the paddle is released. All lights on the Tractor Control Box turn off and the next Tier is ready to begin.

## PATTERN NO. 3 - INTERLOCKING TIE TIER

The Interlocking Tie Tier sequence is activated when LS-5 and LS-6 are both on.

1. Pattern No. 3 begins when two bales enter the upper bale table. When LS-1 & LS-8 are activated, the pusher extends and the bales are pushed on to the load bed until LS-2 is activated, completing a "pusher long stroke." The pusher returns and activates LS-4 and light No. 1 is lit.
2. When LS-1 & LS-8 are activated, the pusher is activated. In this tie pattern, a hydraulic valve allows the tie arms to swing out to turn the bales to the outside edge of the load bed. Once the tie arms have extended, the pusher moves the bales to the left hand side of the load bed until LS-3 is activated, completing a "pusher short stroke." The tie arms retract, then the pusher returns and activates LS-4 and light No. 2 is lit.
3. The third step requires only one bale to activate the pusher. When LS-1 is activated, the pusher extends until LS-3 is activated, and this bale is pushed to the center of the bales previously positioned in step 2. Step 3 occurs 3 times. Light No's 3, 4, and 5 illuminate after each step.
4. The sixth step begins when two bales enter the upper bale table. When LS-1 & LS-8 are activated, the pusher extends and the bales are pushed on to the load bed until LS-3 is activated, completing a "pusher short stroke." As these last 2 bales are pushed across onto the load bed, the index paddle is depressed, triggering LS-7, and the load bed lowers until the paddle is released. All lights on the Tractor Control Box turn off and the next Tier is ready to begin.

# Bale Tier Stack Patterns

## 7 HIGH BALE TIER STACK PATTERNS FOR 15" & 16" 3-TIE BALES

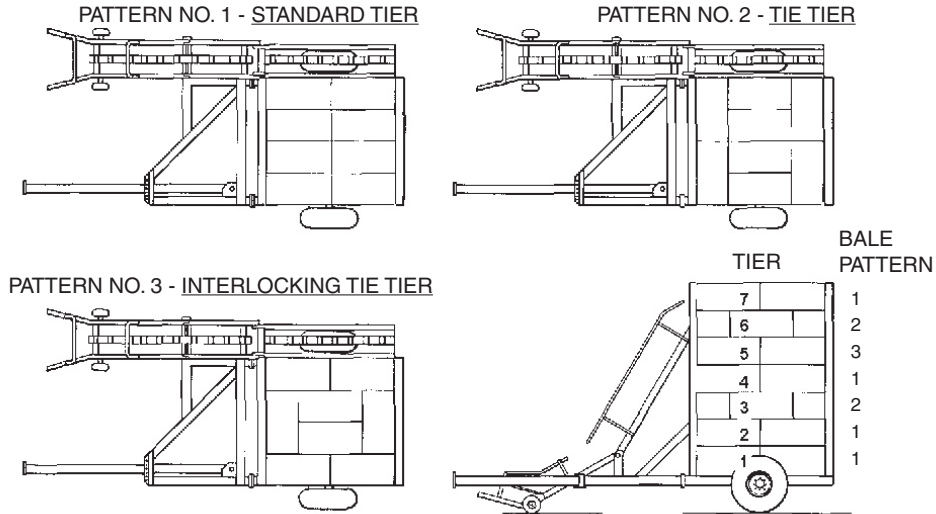

## 7 HIGH BALE TIER STACK PATTERNS FOR 16" 2-TIE BALES

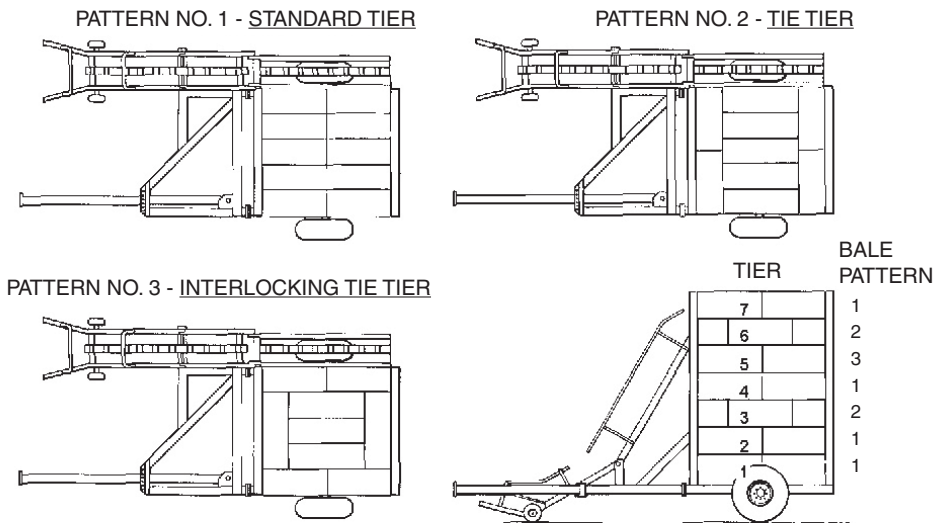

## 8 HIGH BALE TIER STACK PATTERNS FOR 14" 2 & 3-TIE BALES

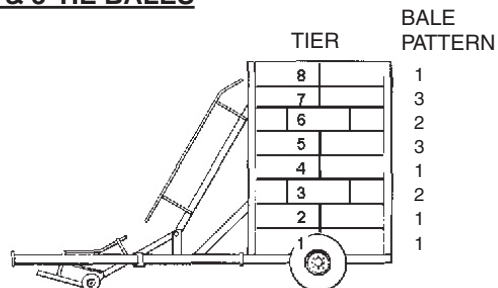

Figure 17 - Stack Patterns

# Solenoid Valve Diagnostics

## Manual Operation of Solenoid Valve

**WARNING**

It is recommended that this diagnostic mode be conducted with the PTO disengaged and the tractor parked and the brake on. This diagnostic sequence will also allow the user to operate hydraulic functions that could cause damage to the machinery or bales if they are still on Load Bed during this operation. All bales should be out of the way of operating hydraulic functions.

There are some solenoid valves that are not directly operable from the Tractor Control box when in the "Pause" Mode. A Diagnostics section has been developed to allow the output to the solenoid from the computer system to be operated. This is very useful when troubleshooting the system.

### To enter the Solenoid Valve Manual Operation Diagnostic Mode

1. Set the MODE switch to the STOP position.
2. Hold the COUNT and WORK LIGHT buttons for 3 seconds.
3. The Indicator Lights 5 and 6 will flash on for 1 second and then off for 1 second. This indicates that the computer system is in the Solenoid Valve Manual Operation Diagnostics Mode.
4. Once in this mode, use the COUNT button to cycle to the first valve to be checked. See the table below to see which valves can be manually operated.

Valve # On Manifold	Valve Function	Display
32	Tie Arms Extend	
8	Bale Table Chain	

**Note that valve #8 will only operate if Limit Switch-4 is on.**

5. Set the MODE switch to the PAUSE position.
6. When the appropriate valve has been selected, use the PICKUP CHAIN MOMENTARY FORWARD button to activate the output from the computer system to the valve. When the signal is being sent, indicator light 7 will continue to illuminate as long as the PICKUP CHAIN MOMENTARY FORWARD button is being pressed. (At this time, the valve can be tested to see if it is receiving a signal)

**NOTE: The MODE switch must be in the PAUSE position for a signal to be sent to the solenoid valve.**

7. If necessary the MODE switch can be placed in the PAUSE position, and other manual functions operated at the same time in conjunction with these valves. In order to do this for the Tie Arms and the Pusher do the following:
  - a. While in the Solenoid Valve Manual Operation Diagnostic Mode, position the MODE switch to the PAUSE position.
  - b. Press and hold the PICKUP CHAIN MOMENTARY FORWARD button, then press and hold the PUSHER switch to the EXTEND position. The tie arms should fully extend, then the pusher will extend.
  - c. Release the Pusher EXTEND switch and allow the switch to come to the centered position.
  - d. To retract the Pusher, press and hold the PUSHER switch to the RETRACT position. The Tie Arms should retract and then the Pusher should retract.

### Exiting the Solenoid Valve Manual Operation Diagnostic Mode

Place the MODE switch in the PAUSE position, then back to the STOP position. If already in the PAUSE position, (i.e. using other manual functions) then place the switch in the STOP position.

This will exit the Solenoid Valve Manual Operation Diagnostic Mode and the indicator lights will return to their original state before entering the Diagnostics Mode.

---

# Limit Switch Diagnostics



## WARNING

**Make certain that all personnel and equipment are clear of the machine before starting operation.**

### Limit Switch Diagnostics Mode

The tractor control box can be used to test the bale wagons limit switches. This test will indicate if/when the controller is receiving a 12 volt signal from the limit switch.

1. Place the POWER switch in the ON position
2. Place the MODE switch in the STOP position
3. Hold the WORK LIGHTS button down for 3 seconds and release. Indicator light #6 will begin flashing, indicating that the system is in the Limit Switch Diagnostics Mode and will be testing LS-1.
4. The Diagnostics Mode will always start in the test mode for LS-1
5. Lights 1 - 4 are used to indicate which limit switch is being tested. See Figure 18 for limit switch identification and Figure 14 for limit switch locations.
6. Press and release the COUNT button to advance through limit switches 1 - 16. Pressing the count button again after LS-16, will return to LS-1.

Light #7 is used to test for a signal from the limit switch.

Light #7 will be illuminated when the controller receives a 12 volt signal from the selected limit switch and will stay on as long as that signal is received.

### Operating Hydraulic Functions while in the Limit Switch Diagnostics Mode

The hydraulic functions can be operated while in the Limit Switch Diagnostics Mode in order to activate and de-activate the limit switches to test their functionality.

1. While still in the Limit Switch Diagnostics Mode, place the MODE switch in the PAUSE position. Light #6 should continue to flash, indicating that the diagnostics mode is still activated.
2. The manual controls on the tractor control box can now be used to activate the hydraulic functions to operate the limit switches.
3. The COUNT button is still used to advance through the limit switches, (see #6 above).

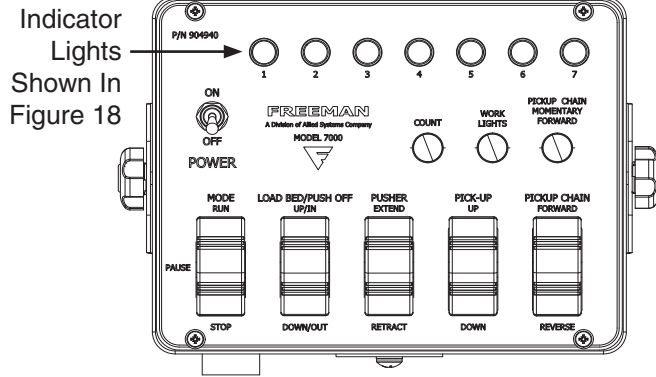

## Exiting the Limit Switch Diagnostics Mode

Place the MODE switch in the PAUSE position, then back to the STOP position. If already in the PAUSE position, (i.e. using hydraulic functions) then place the switch in the STOP position.

This will exit the Limit Switch Diagnostic Mode and the indicator lights will return to their original state before entering the Diagnostics Mode.

	Switch Being Tested					Signal Indicator Light	
	1	2	3	4	5	6	7
LS-1	○	○	○	○	○	●	○
LS-2	●	○	○	○	○	●	○
LS-3	○	●	○	○	○	●	○
LS-4	●	●	○	○	○	●	○
LS-5	○	○	●	○	○	●	○
LS-6	●	○	●	○	○	●	○
LS-7	○	●	●	○	○	●	○
LS-8	●	●	●	○	○	●	○
LS-9	○	○	○	●	○	●	○
LS-10	●	○	○	●	○	●	○
LS-11	○	●	○	●	○	●	○
LS-12	●	●	○	●	○	●	○
LS-13	○	○	●	●	○	●	○
LS-14	●	○	●	●	○	●	○
LS-15	○	●	●	●	○	●	○
LS-16	●	●	●	●	○	●	○

Figure 18 - Limit Switch Diagnostic Identification

# Over Cycle Time Diagnostics

## Over Cycle Time

When in the “Run” mode the system will be measuring the amount of time it takes for the following functions to occur:

Function	Allowable Time
Pusher Extend to LS-3 (Short Push)	4 seconds
Pusher Extend to LS-2 (Long Push)	4 seconds
Pusher Retract to LS-4 (Pusher Return)	4 seconds
Load Bed Lower until LS-7 Activated	4 seconds

The elapsed time will be calculated starting when the function is signaled to start and when the modules receives the signal from the limit switch activated above. If these times are equal to or greater than the Allowable Time, the system will provide a visual indication to the operator through the Indicator Lights. Please see the table below for the lights activated for a particular situation.

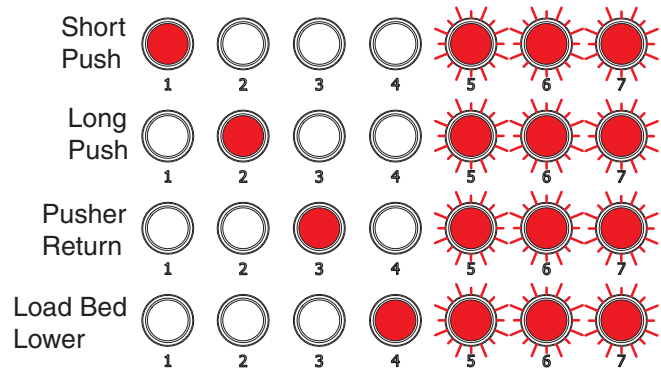

The computer system will continue to try and drive the function until the limit switch is activated. Once the switch is activated the machine will continue operation.

When one of these Over Cycle Time events occur, the following is advisable:

1. Disengage the tractor PTO.
2. Bring the tractor to a complete stop.
3. Engage the tractor parking brake.
4. Determine the issue that caused the Over Cycle Time condition. Please refer to the troubleshooting section for more information.



## Loss of Signal

If any of the below situations occur, the machine will go into a mode where all outputs will be disabled from the computer. In this state the indicator lights 1 through 7 will flash.

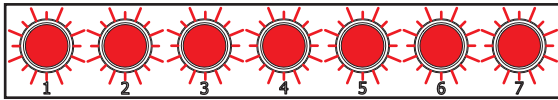

This sequence will be on for 1 second and off for 1 second.

This can happen for any of the following reasons.

1. Tractor control box power switch turned ON with MODE switch in the RUN or PAUSE position.
  - Reset by placing the MODE switch in the STOP position. Lights will stop flashing and PAUSE & RUN modes will be available.
2. Service ladder gate (LS-13) is open.
  - Close & latch the service ladder gate.
3. Loss of electrical signal from LS-13.
  - Check wiring and repair if needed.
  - Check limit switch and replace if malfunctioning.

# Limit Switch Setup and Adjustments

The limit switch locations shown in this section are for reference only, and may require adjustment to get the optimum results for your specific field and bale conditions. It is recommended that you record the positions that work best for you.

See Figure 14 on page 25 for an overview of limit switch locations.

## NOTICE

All measurements shown in this section are for 14" 2-Tie bales



## WARNING

Tractor and bale wagon must be on level ground. The tractor brakes and or transmission must be locked. Tractor and bale wagon must be turned off with no power to the PTO shaft.



Figure 19 - LS - 1, 8, 9 Locations

## Setting Actuator Stop Bolt

This procedure is for use with Limit Switches LS-1, LS-8, LS-9, LS-14 and LS-15 (see "Figure 14 - Limit Switch Locations" on page 25).

## Adjustment Objective

The stop bolt is used to determine how far the activation paddle will press the limit switch actuator into the bottom of the limit switch. If the bolt is not adjust out far enough the activation paddle will cause the switch actuator to go too far into the limit switch and could result in damage. If the bolt is adjusted too far out the activation paddle will not press the actuator deep enough to cause the switch to activate. The actuator should move no more than 1/32 - 1/16" (0.5 - 1.5 mm).

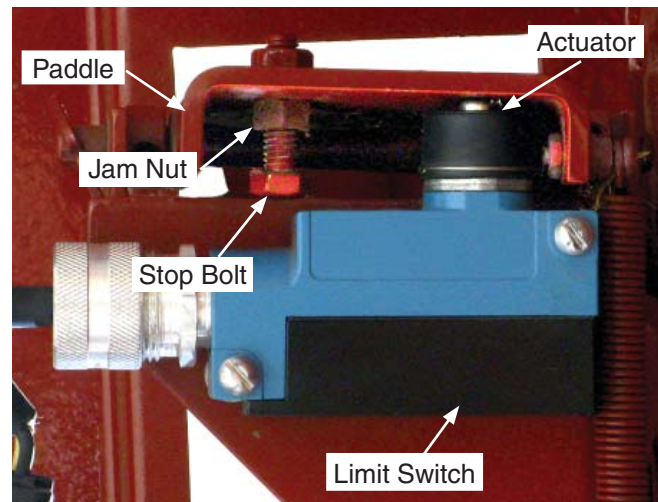

Figure 20 - Actuator Stop Bolt Adjustment

## Adjustment Procedure

1. Loosen the jam nut on the stop bolt (see Figure 20).
2. Bring the paddle to the limit switch actuator until the switch is activated. The switch activates as soon as the actuator moves inwards.
3. Adjust the position of the stop bolt to allow the actuator to engage the switch but not to depress it more than 1/16" (1.5 mm). Secure the position of the stop bolt by tightening the jam nut.

## LS-1

### Adjustment Objective

LS-1 should be adjusted so that when the center bale is placed on the bale table it is positioned approximately in the center of the load bed so it can easily be pushed into the stack. This positioning is important for pattern 2 and pattern 3 when putting the center bales into the stack (see Figure 15).

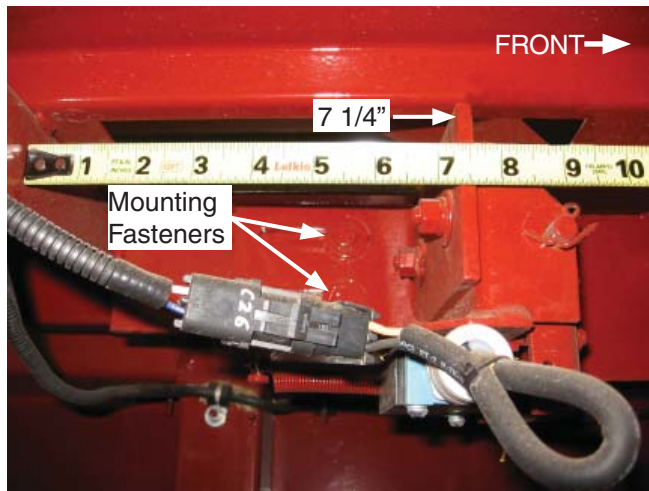

Figure 21 - Limit Switch - 1 Adjustment

### Adjustment Procedure

1. Verify the stop bolt is operating properly. Refer to Setting Actuator Stop Bolt (see page 34).
2. Use a wrench to loosen mounting fasteners holding the limit switch bracket.
3. Slide the limit switch bracket along the slots to the desired position. It is best to make small increments of adjustment and then watch the changes in the machine performance.
  - If the bale is being positioned too far to the rear of the machine then move the bracket to the front of the machine.
  - If the bale is being positioned too far to the front of the machine then move the bracket to the rear of the machine.
4. Secure the mounting fasteners when the adjustment is complete.

## NOTICE

*You must take in to account that the pushers momentum will allow it to travel some distance after triggering limit switches 2, 3 and 4 when operating at normal operating speed (540 RPM).*

## LS-2

### Adjustment Objective

LS-2 should be adjusted such that the Pusher extends to within 1" of its full stroke on a long push. The exact dimensions will change based on the variations in the flow rate of the tractor and the friction and wear of the Pusher frame.

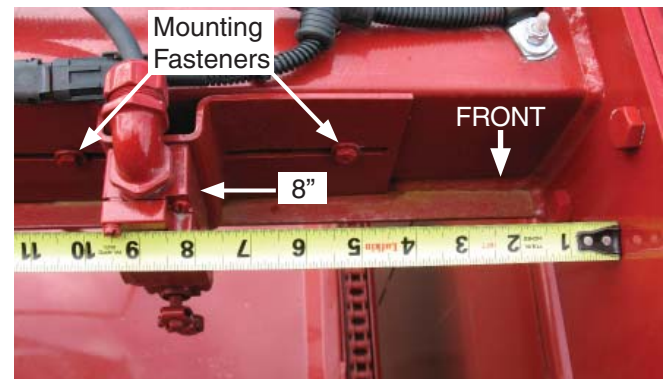

Figure 22 - Limit Switch - 2 Adjustment

### Adjustment Procedure

1. Use a wrench to loosen the mounting fasteners holding the limit switch bracket (see Figure 22).
2. Adjust the arm so it is pointing straight down. The arm should be positioned such that it will not bind or bend when contacting the cam surface. This will happen if the roller is adjusted to contact the surface at a perpendicular angle.
3. Adjust the limit switch bracket.
  - If the cylinder is extending too far, adjust the bracket to the right-hand side of the machine.
  - If the cylinder is not extending far enough, adjust the bracket to the left-hand side of the machine.
4. Secure the mounting fasteners when the adjustment is complete.

## LS-3

### Adjustment Objective

LS-3 should be adjusted such that the Pusher deposits the bales onto the Load Bed such that the bales are off the Bale Table and past the Push Off Bar chain.

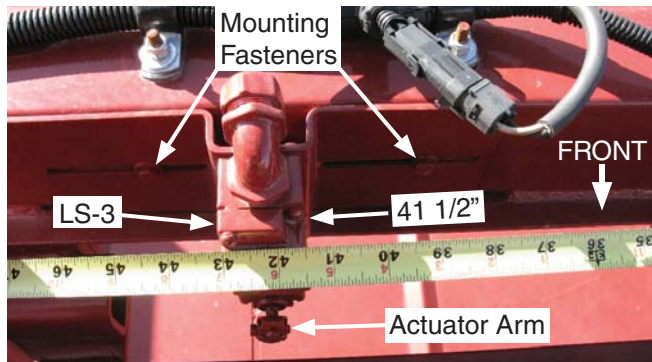

Figure 23 - Limit Switch - 3 Adjustment

### Adjustment Procedure

1. Use a wrench to loosen the mounting fasteners holding the limit switch bracket.
2. Adjust the arm so it is pointing straight down. The arm should be positioned such that it will not bind or bend when contacting the cam surface. This will happen if the roller is adjusted to contact the surface at a perpendicular angle.
3. Adjust the limit switch bracket.
  - If the cylinder is extending too far, adjust the bracket to the right-hand side of the machine.
  - If the cylinder is not extending far enough, adjust the bracket to the left-hand side of the machine.
4. Secure the mounting fasteners when the adjustment is complete.

## LS-4

### Adjustment Objective

LS-4 should be adjusted such that the Pusher retracts out of the way of bales coming on to the Bale Table, but does not exceed the retract distance of the cylinder. If the cylinder does not retract far enough, it will cause bales to hang up on the Pusher Frame. If the cylinder retracts too far, the cylinder will exceed its retracted length and bottom out.

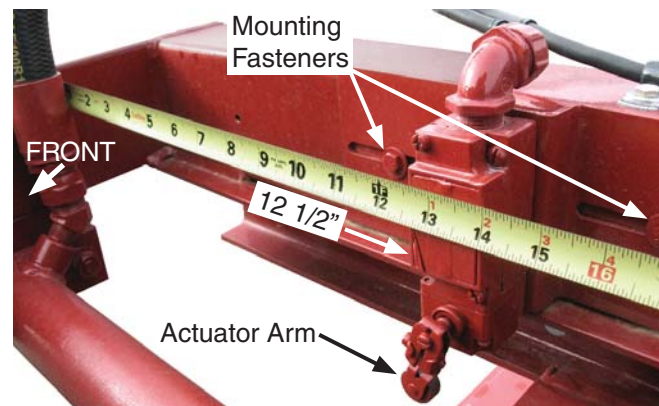

Figure 24 - Limit Switch - 4 Adjustment

### Adjustment Procedure

1. Adjust the arm so it is pointing straight down. The arm should be positioned such that it will not bind or bend when contacting the cam surface. This will happen if the roller is adjusted to contact the surface at a perpendicular angle (see Figure 24).
2. Use a wrench to loosen the mounting fasteners holding the limit switch bracket.
3. Adjust the limit switch bracket.
  - If the cylinder is retracting too far, adjust the bracket to the left-hand side of the machine.
  - If the cylinder is not retracting far enough, adjust the bracket to the right-hand side of the machine.
4. Secure the mounting fasteners when the adjustment is complete.

## LS-5, LS-6

### Adjustment Objective

LS-5 and LS-6 should be adjusted such that the limit switches are fully engaged by the Tie Tier Cams as they make contact on the Tie Tier Cam surfaces. If the limit switches are not making adequate contact, the Tie Tier Cams may need to be adjusted after the limit switch has been adjusted (see Figure 7 on page 14 for Cam installation locations).

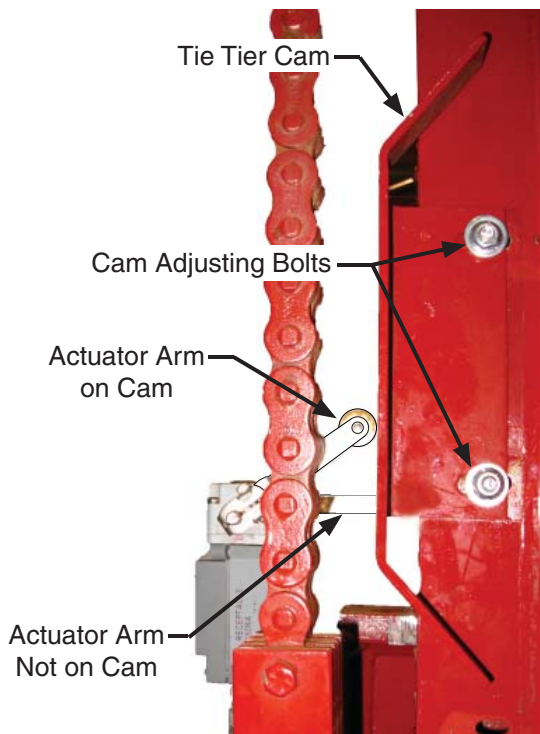

Figure 25 - Limit Switch - 5 & 6, Cam Adjustment

### Adjustment Procedure

1. Adjust the arm so it is pointing straight back. The arm should be positioned such that it will not bind and bend when contacting the cam surface. This will happen if the roller is adjusted to contact the surface at a perpendicular angle (see Figure 25).
2. Use a wrench to loosen the cam adjusting bolts holding the Tie Tier Cams.
3. Adjust the Tie Tier Cams by sliding the assembly in the slots. Adjust the Cams so that the actuator arms move enough to engage the switch when the switch passes a cam.
4. Secure the mounting fasteners when the adjustment is complete.

## LS-7 Adjustment Objective

LS-7 should be adjusted such that the switch closes when there are no bales under the Index Paddle and the switch deactivates when the Index Paddle is raised by a bale. The Index Paddle should be adjusted such that it deactivates and stops the load bed 0" - 2" below the bale table to receive the next tier. This range of adjustment will vary depending on variations with material and bale shape. Additional adjustment might need to be made to the Index Paddle Arm if the Index Paddle Mount cannot be adjusted any farther (see Figure 27).

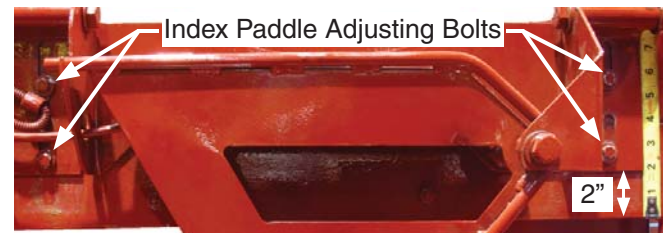

Figure 26 - Limit Switch - 7, Mount Adjustment

### Adjustment Procedure

1. Adjust the arm to properly contact the Index Paddle. The actuator should not be positioned such that it will bind and bend when contacting the cam surface. This will happen if the roller is adjusted to contact the surface at a perpendicular angle (see Figure 26).
2. Use a wrench to loosen the adjusting bolts holding the Index Paddle.
3. Adjust the Index Paddle by sliding the assembly in the slots.
  - Adjust the assembly up if the Load Bed is going too far down.
  - Adjust the assembly down if the load bed is not going down far enough.
4. Secure the mounting fasteners when the adjustment is complete.
5. If additional adjustment is required after moving the Index Paddle, bend the Paddle Arm to achieve the desired height (see Figure 27).

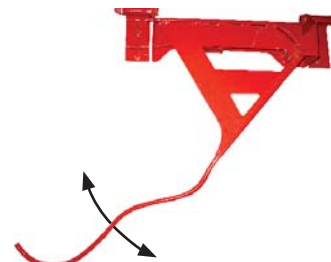

Figure 27 - Limit Switch - 7, Paddle Arm Adjustment

## LS-8 & LS-9

### Adjustment Objective

LS-8 & LS-9 (see Figure 28) work in conjunction with LS-1 and LS-14 to properly locate the bales on the bale table (see Figure 34 on page 40). The only adjustment for LS-8 & LS-9 is the stop bolt.

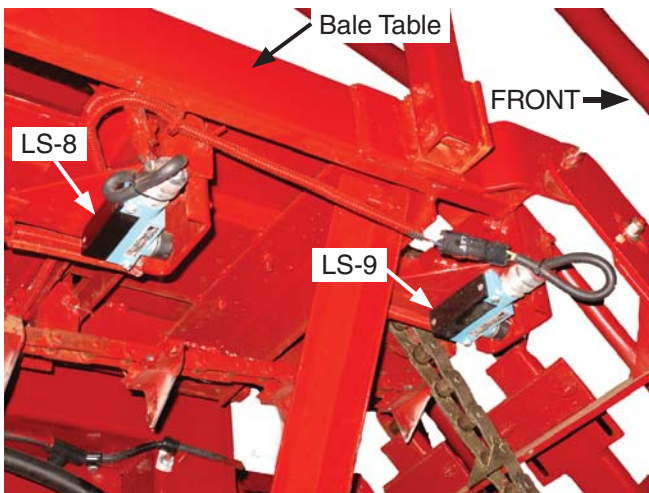

Figure 28 - Limit Switch - 8 & 9 Adjustment

### Adjustment Procedure

1. Verify the stop bolt is operating properly (see “Setting Actuator Stop Bolt” on page 34).

## LS-10

### Adjustment Objective

LS-10 should be adjusted such that the switch is activated when the Bale Retainer is raised all the way up which occurs when the Load Bed Cylinder is completely retracted. LS-10 is activated by a small metal pad that is mounted to the Bale Retainer. LS-10 should remain activated after the Bale Retainer has completely lifted and the Push Off Bar is operable.

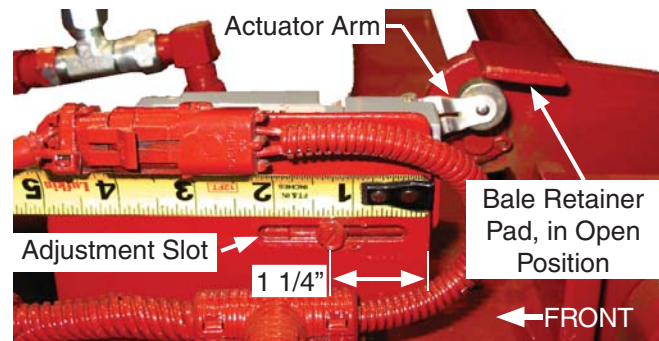

Figure 29 - Limit Switch - 10 Adjustment  
(View from Left Side of Bale Wagon)

### Adjustment Procedure

1. Adjust the arm to contact on the bottom surface of the metal pad on the Bale Retainer. The arm should be positioned such that it will not bind or bend when contacting the pad surface. This will happen if the roller is adjusted to contact the surface at a perpendicular angle (see Figure 29).
2. Use a Phillips head screw driver to loosen the mounting fasteners holding the limit switch to the bracket.
3. Adjust the position of the switch inside the slots.
4. Secure the mounting fasteners when the adjustment is complete.

## LS-11

### Adjustment Objective

LS-11 should be adjusted such that the Push Off Bar retracts to the front end of the Load Bed and stops shortly before making contact with the structure of the Load Bed.

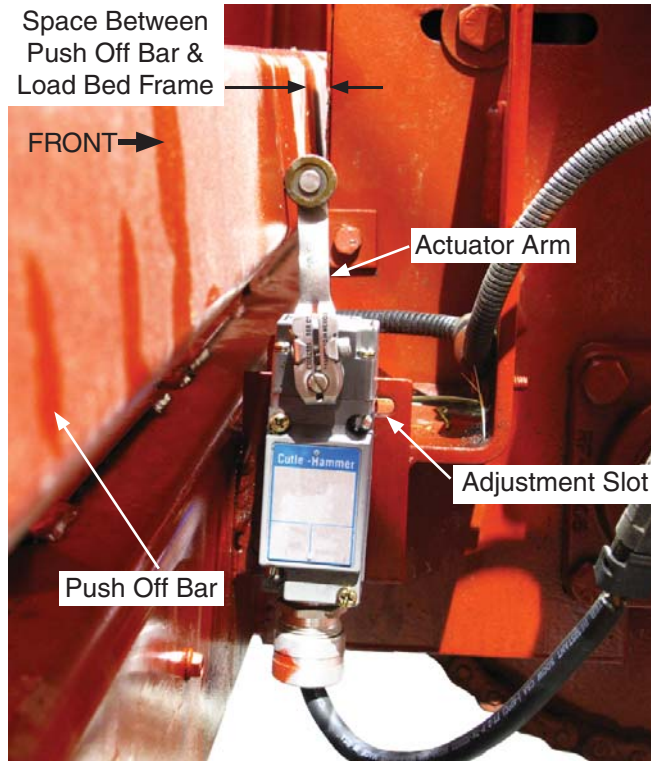

Figure 30 - Limit Switch - 11 Adjustment

### Adjustment Procedure

1. Adjust the arm so that it properly contacts the Push Off Bar. The arm should be set so it is not pointing directly at the Push Off Bar, as that could cause the arm to bend (see Figure 30).
2. Use a Phillips head screw driver and wrench to loosen the fasteners that hold the limit switch to the mount.
3. Adjust the limit switch in the slots.
  - If the Push Off Bar is stopping too far away from the front of the machine move the limit switch forward towards the front of the machine.
  - If the Push Off bar is stopping too close to the front of the machine move the limit switch backwards to the rear of the machine.
4. Secure the mounting fasteners when the adjustment is complete.

## LS-12

### Adjustment Objective

LS-12 should be adjusted such that the switch is activated when the Load Bed lowers and makes contact with the front, left-hand side of the frame, and before the rear of the Load Bed begins to lower for the unloading of the stack.

### Adjustment Procedure

1. Adjust the arm so that it properly contacts the cam surface on the head of the Load Bed Cylinder. The arm should be positioned such that it will not bind or bend when contacting the cam surface. This will happen if the roller is adjusted to contact the surface at a perpendicular angle (see Figure 31).
2. Use a Phillips head screw driver and wrench to loosen the fasteners that hold the limit switch to the mount and/or loosen the bolts that secure the limit switch mount.
3. Adjust the limit switch in the slots.
  - If the Load Bed is stopping too low move the switch up.
  - If the Load Bed is stopping too high move the switch down.
4. Secure the mounting fasteners when the adjustment is complete.

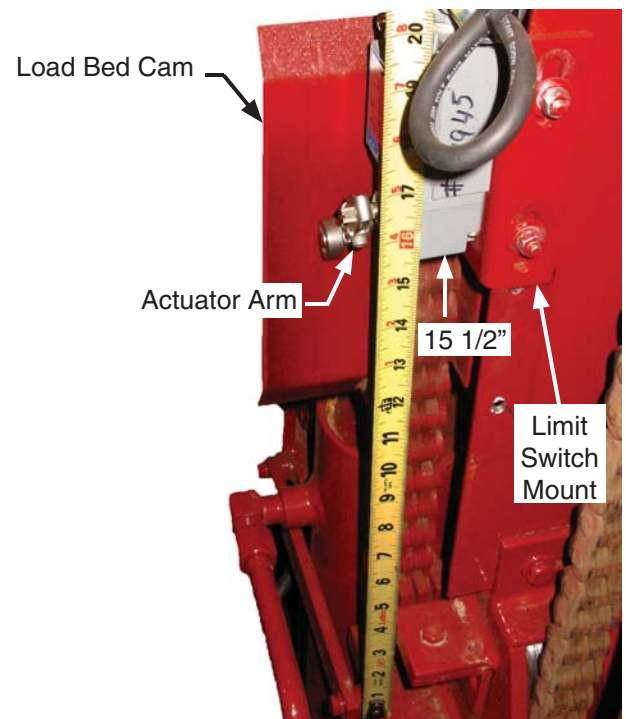

Figure 31 - Limit Switch - 12 Adjustment

## LS-13

### Adjustment Objective

LS-13 should be adjusted such that the service ladder door causes the switch to activate when the door is opened, and continues to be activated with the service door unlatched. There is no other adjustment on this switch other than the actuator arm.

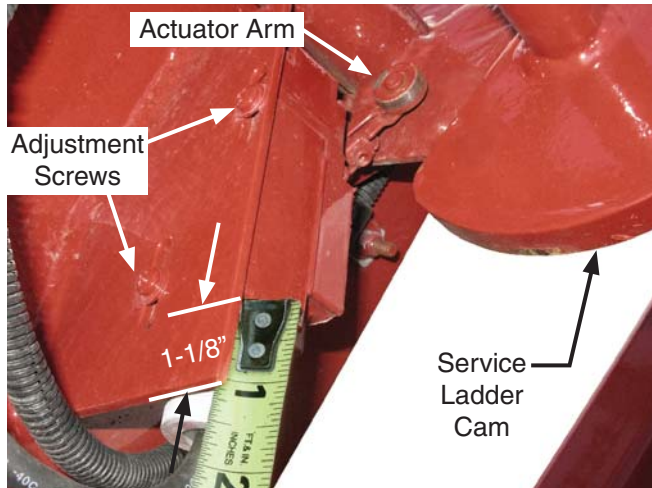

Figure 32 - Limit Switch - 13 Arm Adjustment

### Adjustment Procedure

1. Use a Phillips head screwdriver to loosen the mounting fasteners holding the limit switch (see Figure 32).
2. Adjust the arm such that it will not bind or bend when contacting the cam surface. This will happen if the roller is adjusted to contact the surface at a perpendicular angle.
3. Adjust the limit switch location so that the switch is activated after the door is free of the door latch, but while the door is still blocking access to the ladder.
4. Secure the mounting fasteners when the adjustment is complete.

## LS-14

### Adjustment Objective

LS-14 should be adjusted such that the 2nd bale to enter the Bale Table actuates LS-8 before deactivating LS-14. When properly adjusted LS-14 will allow the bales to enter the Bale Table and settle out of the way of the frame of the Bale Wagon before the Pusher activates and pushes the bales onto the table. See Figure 34 for Bale Table Paddle locations.

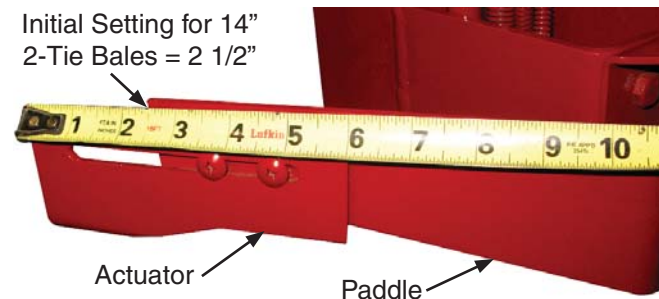

Figure 33 - Limit Switch - 14 Arm Adjustment

### Adjustment Procedure

1. Verify the stop bolt is operating properly (see “Setting Actuator Stop Bolt” on page 34).
2. Use a Phillips head screw driver and wrench to loosen the actuator fasteners (see Figure 33)
3. Adjust the actuator on the end of the paddle.
  - If LS-14 is deactivating too soon then extend the paddle by extending the length of the actuator.
  - If LS-14 is deactivating too late retract the paddle by shortening the length of the actuator.
4. Secure the mounting fasteners when the adjustment is complete.

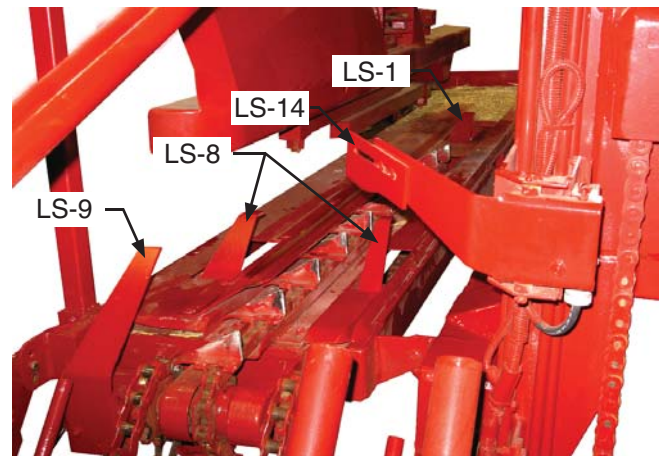

Figure 34 - Limit Switch - 1, 8, 9, 14 Paddle Locations



## LS-15

### Adjustment Objective

LS-15 should be adjusted such that the Push Off Bar pushes a full stack of bales off of the Load Bed and onto the ground and does not allow the Push Off Bar to travel beyond the rear frame tube of the Load Bed. A roller mounted to an arm on the Push Off Bar will activate the LS-15 switch. If additional adjustment is needed this roller mount can also be adjusted.

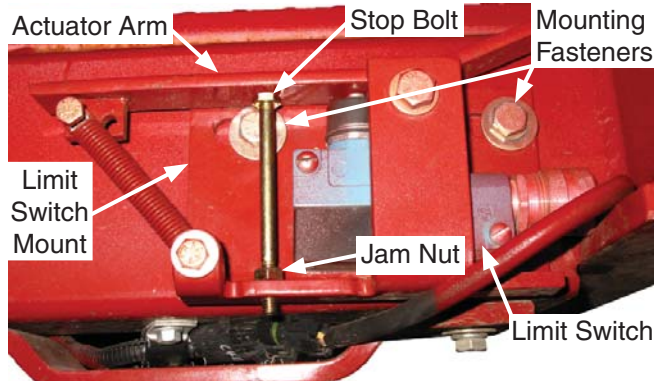

Figure 35 - Limit Switch - 15 Adjustment

### Adjustment Procedure

1. Use a wrench to loosen the mounting fasteners.
2. Adjust the position of the limit switch mount (see Figure 35) or the Roller (see Figure 36).
  - If the Push Off Bar is not going far enough back and the bales are not being pushed all the way off the Bale Table adjust the limit switch mount to the rear of the machine or adjust the roller to the front of the machine.
  - If the Push Off Bar is going too far back and contacting the rear frame tube on the Load Bed, adjust the limits switch mount towards the front of the machine or adjust the roller towards the rear of the machine.
3. Secure the mounting fasteners when the adjustment is complete.

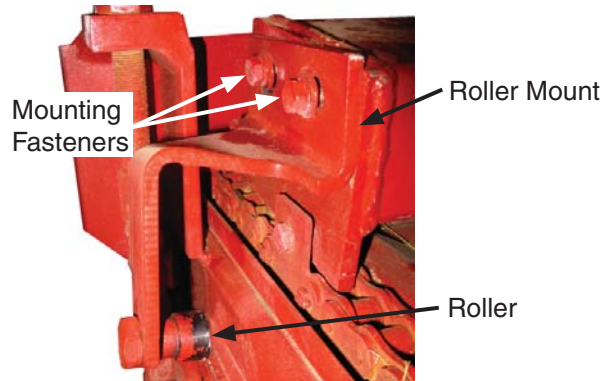

Figure 36 - Push Off Bar Roller Adjustment

## LS-16

### Adjustment Objective

LS-16 should be adjusted such that the limit switch is actuated when the Load Bed is at its highest point and the Load Bed is positioned such that is either level with, or below the Bale Table by no more than 5" +/- 0.5"

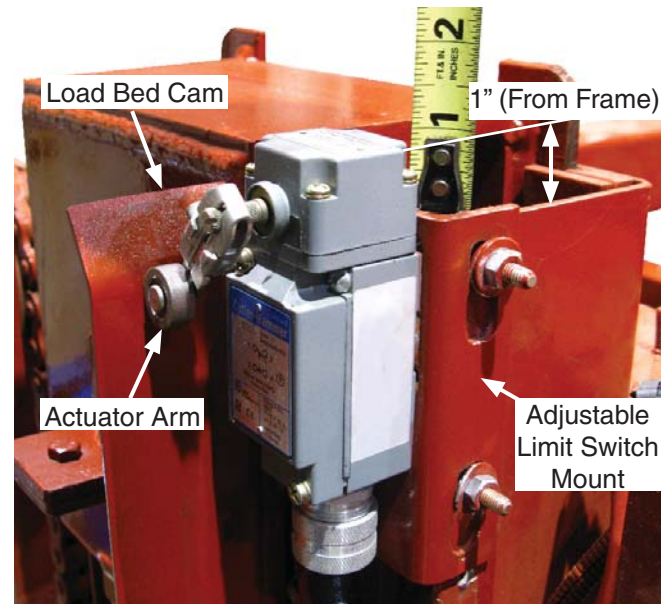

Figure 37 - Limit Switch - 16 Adjustment

### Adjustment Procedure

1. Adjust the arm so it is positioned properly to touch the cam. The arm should be positioned such that it will not bind or bend when contacting the cam surface. This will happen if the roller is adjusted to contact the surface at a perpendicular angle (see Figure 37).
2. Use a Phillips head screw driver and wrench to loosen the fasteners that hold the limit switch to the mount and/or loosen the bolts that hold the limit switch mount to the frame.
3. Adjust the position of the limit switch.
  - If the Load Bed is not high enough adjust the limit switch mount up.
  - If the Load Bed is coming to high and hitting the frame or the cylinder is bottoming out adjust the limit switch down.
4. Secure the mounting fasteners when the adjustment is complete.

# Hydraulic System Valve Setting Procedure

## NOTICE

- All settings are to be made with the Main Gear Pump running at 540 RPM.
- Hydraulic Oil Temperature should be 100 to 120 °F (37.8 to 48.9 °C)
- Required to have Hydraulic Schematic 904907
- All target pressure settings are +/- 100 psi (+/- 690 kpa) unless otherwise specified.
- All safety precautions must be taken to prevent injury and damage to the machinery as outlined in this Operator's Manual.
- See "Figure 39 - Hydraulic Manifold Valve & Test Port Locations" on page 43 for valve and test port locations.

### Recommended Tools:

- External Pressure Test Port adapter ASC P/N: 259170.
- Hydraulic Pressure gauge: 0-3000 psi (0-21,000 kpa) range with adaptors as needed for External Pressure Test Adapter ASC P/N: 259170 .
- Tachometer for measuring shaft rotational speed.
- Basic hand tools for English (SAE) units.

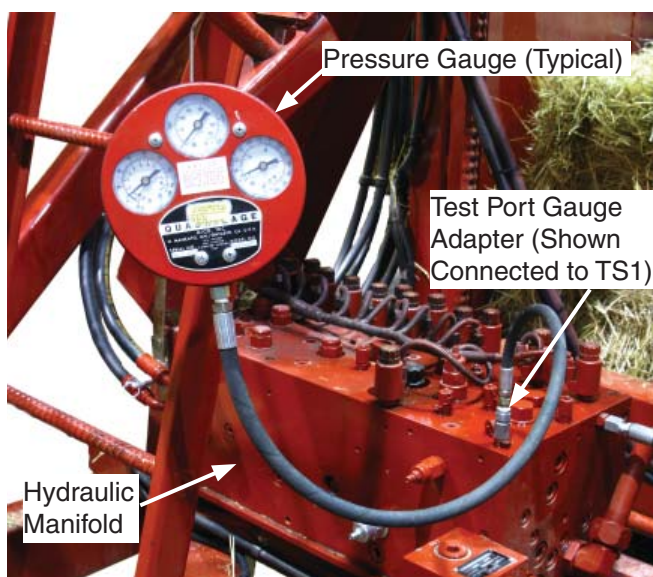

Figure 38 - Pressure Gauge Connection

### 1. Main System Relief Valve (Valve #17)

- Target Setting = 2200 psi (15,000 kpa)

#### Procedure

- A. Attach pressure gauge to Test Port TS1.
- B. Turn on Power to system.
- C. Extend Pickup Lift cylinder (switch in the UP position) until it bottoms out and continue to hold the switch in this position.
- D. Adjust the Main System Relief valve #17 until the gauge reads the target setting.

### 2. Bed Lift and Bale Retainer Counterbalance Valve (Valve ASC P/N: 904888)

- Target Setting = 700 psi (4800 kpa) at remote pilot or 1200 psi (8300 kpa) at TS1.

#### Procedure

- A. Attach pressure gauge as close to the Bale Retainer CB Valve as possible (located near the bottom of the lift bed cylinder) or at TS1.
- B. Turn on power to system.
- C. Lower Bed Lift Cylinder with no load on it and adjust the valve until the gauge reads the target setting for the appropriate location.

### 3. Pickup Lift Cylinder Counterbalance Valve (Valve #22)

- Target Setting = 2000 psi (13,800 kpa)

#### Procedure

- A. Attach pressure gauge at TS2.
- B. Turn on power to system.
- C. Retract Pickup Lift cylinder (switch in the DOWN position) unloaded until it begins to move and adjust the pressure setting until the gauge reads the target setting. The Pickup Lift Cylinder and Pickup must be in motion in the up direction when taking the pressure measurement.

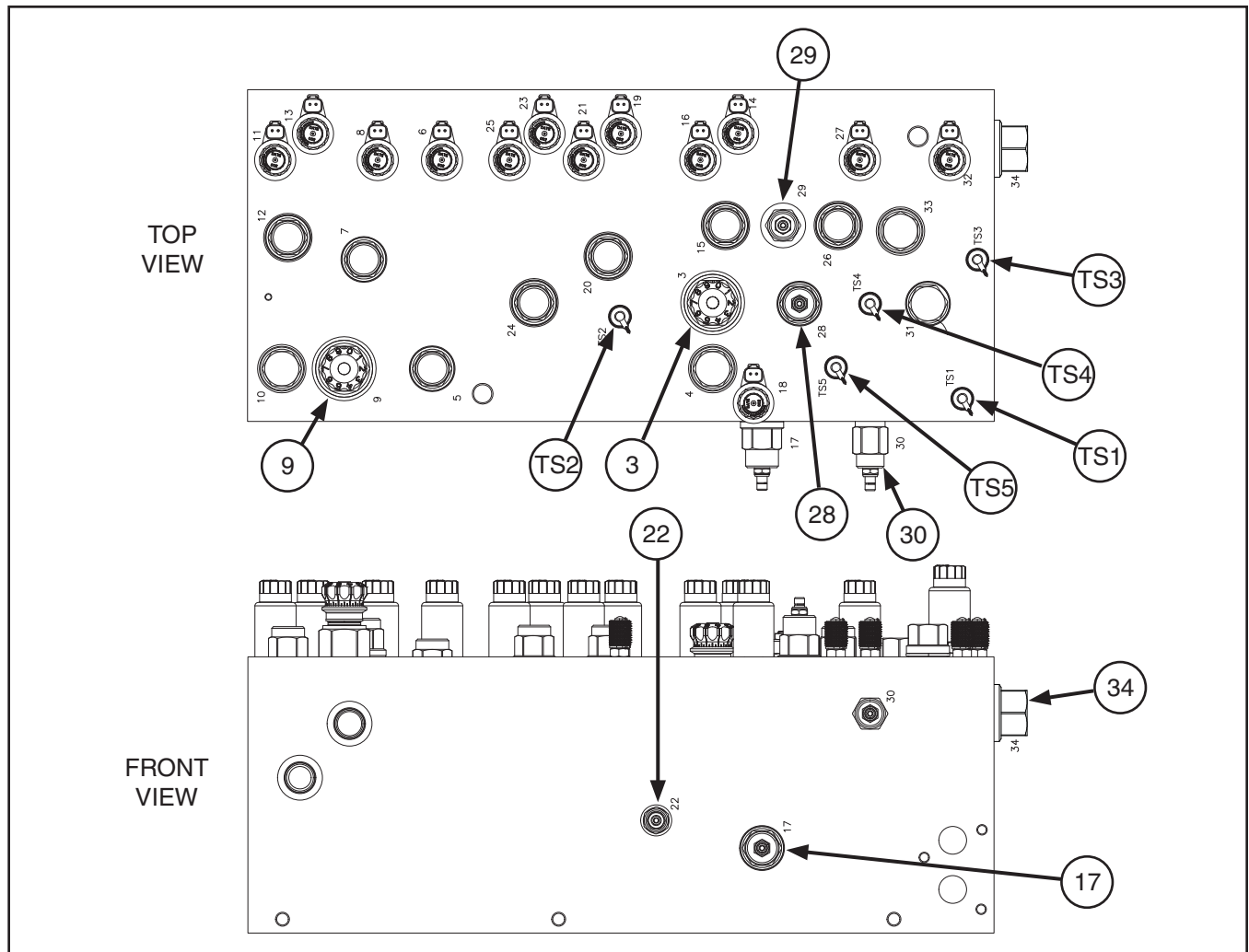

Figure 39 - Hydraulic Manifold Valve & Test Port Locations

#### 4. Pusher Counterbalance Valve (Valve #29)

– Target Setting = 1000 to 1200 psi (6900 – 8300 kpa)

##### Procedure

- A. Attach pressure gauge at TS3.
- B. Turn power on to the system.
- C. Retract Pusher and adjust the setting until the gauge reads to target setting above. The Pusher must be in motion in the retracting direction when taking the pressure measurement.

#### 5. Tie Arms Sequence Valve (Valve #28)

– Target Setting = 1500 psi (10,300 kpa)

##### Procedure

- A. Attach pressure gauge at TS5.
- B. Completely back out the adjustment screw Pusher Relief Valve #30 to reduce the relief pressure setting as low as possible (see 6 below for procedure to re-set the Pusher Relief Valve #30).
- C. Drive the Tie Arms and Pusher until the Tie Arms are fully extended and bottomed out.



## WARNING

Watch out for the pusher, it may extend

- D. Adjust the setting of the Tie Arm Sequence valve #28 until the gauge reads the target setting.

---

## 6. Pusher Relief Valve (Valve #30)

- Target setting = 1000 psi (6900 kpa)

### Procedure

- A. Attach pressure gauge as TS4.
- B. Extend the Pusher so the cylinder bottoms out and adjust the relief valve until the gauge reads the target setting.

## 7. Pick Up Chain, Pickup Lift, & Push Off Flow Control Valve (Valve #3)

- Target Setting = 131 RPM
- The flow of this setting is typically set while monitoring the performance of the Pickup Chain. The target setting shown here is a starting point and the final setting will depend on the condition of the material being processed. The speed of the Bale Table Chain can require adjustment in the field to achieve the following:

- A. The speed of the Pickup Chain should be set so that bales make a smooth transition from the ground to the Pickup without causing strings to break or damage to the bale.
- B. The transition from the Pickup Chain to the Bale Table Chain should be smooth and the speeds close enough that the bale does not make a large acceleration causing either the strings to break or the bale to become damaged.

### Procedure

- A. Procure a tachometer or equivalent device for measuring the rotational speed of the motor.
- B. Setup the apparatus.
- C. Activate the Pickup Chain unloaded and adjust the flow control by lifting the black knob on the flow control valve and turning it in increments to achieve the target setting.

### Alternative Method

- A. Tie a piece of twine to the Pickup Chain.
- B. Run the Pickup Chain and count the number of times the twine passes the same point on the table in 1 minute. This value should be approximately 18 passes when the flow is set to 131 RPM.

## 8. Table Chain Flow Control (Valve #9)

- Target Setting = 131 RPM.
- The target setting shown here is a starting point and the final setting will depend on the condition of the material being processed. The speed of the Bale Table Chain can require adjustment in the field to achieve the following:
  - A. 1st bale on table should be moved beyond the Bale Table Chain before the 2nd bale enters the table.
  - B. The final position of the 1st bale should be far enough to the rear of the Bale Table that it touches the back end of the Bale Table.
  - C. The transition from the Pickup Chain to the Bale Table Chain should be smooth and the speeds close enough that the bale does not make a large acceleration causing either the strings to break or the bale to become damaged.

### Procedure

- A. Procure a tachometer or equivalent device for measuring the rotational speed of the Bale Table Chain motor.
- B. Activate the Pickup Chain unloaded and adjust the flow control by lifting the black knob on the flow control valve and turning it in increments to achieve the target setting.

### Alternative Method

- A. Tie a piece of twine to the Pickup Chain.
- B. Run the Pickup Chain and count the number of times the twine passes the same point on the table in 1 minute. This value should be approximately 18 passes when the flow is set to 131 RPM.

# Troubleshooting

## General Theory behind Troubleshooting the 7000 Bale Wagon

The machine operates using a combination of hydraulic, electrical and mechanical inputs. If there is a problem with the function of the machine it is first important to determine which one of these inputs is not functioning properly.

### Mechanical

- This requires knowledge of mechanical systems their components and functions and familiarity with the assembly of the mechanical systems on the machine. Diagnostics are typically conducted by visually inspecting the mechanism and operating it slowly to make sure it visually performs appropriately. If items are mis-adjusted and causing interference, broken or missing these can typically be determined with visual inspection. Fixing mechanical problems typically involves basic hand tools.

All limit switches must be securely fastened and checked for proper adjustment (see "Limit Switch Setup and Adjustments" on page 34).

### Hydraulic

- This requires working knowledge of basic hydraulics and familiarity with the hydraulics system as well as having access to the hydraulic schematic and setup information. Diagnostics are typically conducted by measuring hydraulic pressure and flow and various points in the system and comparing them to the standard values. Addressing hydraulic problems typically involves fixing hydraulic components including pumps, motors, valves, cylinders and hoses and typically involves basic hydraulic tools. Useful tools include pressure gauge capable of measuring 0 to 3000 psi of hydraulic fluid pressure and basic hand tools. A hydraulic test port gauge adapter (P/N 259170) is included with the Bale Wagon.

### Electrical

- This requires knowledge of basic electricity, controller inputs and outputs, switch functions and familiarity with the electrical system and access to the electri-

cal wiring harness drawings and electrical schematic. Diagnostics are typically conducted by measuring voltages from switches to the inputs on the controller and system components and voltages from the outputs of the controller and system components to the loads example: lights, solenoids, relays. Useful tools include a multi-meter, test light and basic hand tools.

In general, each problem will involve an aspect of these three categories. Below are problems that might occur during operation of the machine. In some instances problems may occur that are outside the scope of this trouble shooting guide. In these instances good judgment and a methodical approach are recommended.

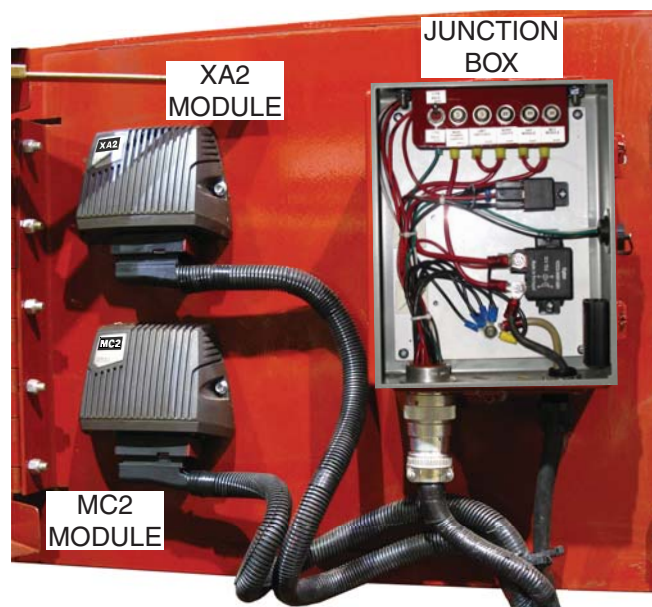

Figure 40 - Electric Panel, on right side of Bale Wagon

Symptom	Problem	Solution
No power to the Bale Wagon	Not enough battery voltage.	Check battery voltage. The battery voltage should be 12 to 14.5 volts.
	Poor Ground	Check that the black ground wire is securely attached to a sufficient ground on the tractor.
	Main Power Cable is not connected to the battery.	Check that the white Main Power Cable is properly connected to a 12 to 14.5 volt power source and that this power can be measured at the Main Power Relay in the Junction Box.
	Main power switch is not operating correctly. The power for the entire system is controlled by the On/Off switch on the Tractor Control Box. This switch turns the Main Power Relay in the Junction Box On & Off. If this switch is not providing power to the Main Power Relay then none of the systems on the machine will receive electricity.	Check that the On/Off switch on the Tractor Control Box is providing power to the Main Power Relay and that the Main Power Relay is supplying power to the bank of fuses in the Junction Box.
	There is power going through the Main Power Relay but there is no power to the rest of the system. The Main Power Relay connects power to the rest of the system through a bank of fuses. The fuses will trip, which breaks the circuit.	Check the bank of fuses in the Junction Box and verify that none of them are tripped. When tripped the round white button in the middle of the fuse will pop out. Press the round white button back in to reset the fuse. If a fuse has been tripped determine the cause before proceeding.
<p>Pusher will not extend when in Automatic Mode.</p> <p><b>Note: If the Pusher is being commanded to extend in the Automatic Mode and LS-3 (on a short stroke) or LS-2 (on a long stroke) is not activated within 4 seconds the Over Cycle Time Diagnostic condition will occur and the program will continue to extend the Pusher until the appropriate limit switch is activated.</b></p>	<p>Pusher delay switches LS-14, LS-9 are not released. Check switches at the entry to the Bale Table. Both switches must be released for pusher to operate. Check switches for mechanical defaults. The release switches are normally open and no voltage should be measured at the controller</p>	<p>Check the limit switches involved in the activation of the Pusher (LS-1, LS-8, LS-9 LS-14) to determine that they are properly sending the electrical signals when needed. Use the Limit Switch Diagnostic to determine if the switches are operating properly (see "Limit Switch Diagnostics" on page 30).</p>

Symptom	Problem	Solution
<p>Pusher will not extend when in Automatic Mode.</p> <p>Continued....</p>	<p>Pusher Trip Switches are not depressed. On a 2-Bale Push both LS-1 and LS-8 must be pressed for the pusher to operate. On a single bale push only LS-1 must be pressed to operate. These switches are normally open until they are activated by the bale and then they are closed. The pusher will not extend automatically unless several conditions are met which are different if it is doing a single bale push or a two bale push. Please refer to the "Flow Chart - Tie Patterns" for those conditions. The Pusher can only be extended manually when in the Pause Mode.</p>	<p>Check the limit switches involved in the activation of the Pusher to determine that they are properly sending the electrical signals when needed. Use the Limit Switch Diagnostic to determine if the switches are operating properly (see "Limit Switch Diagnostics" on page 30).</p>
	<p>The hydraulic Valve #6 and #27 must be activated for the Pusher to extend. These valves might not be receiving voltage.</p>	<p>Check the voltage to the valves. The valve should also be supplied voltage when manually operating the Pusher in the Manual Mode. Use the Manual Mode to check the output from the controller and the wiring from the controller to the solenoids by verifying voltage when extending the Pusher in Manual Mode.</p>
	<p>There is an obstruction in the way of the Pusher. The Over Cycle Time indication sequence will flash on the Indicator Lights if the retract time requires more than 4 seconds.</p>	<p>Check for obstructions that would keep the Pusher from extending. This could be a rolled bale on the Load Bed.</p>

Symptom	Problem	Solution
Pusher fails to retract when in the Automatic Mode. <b>Note: If the Pusher is being commanded to retract in the Automatic Mode and LS-4 is not activated within 4 seconds the Over Cycle Time Diagnostic condition will occur and the program will continue to retract the Pusher until the appropriate limit switch is activated.</b>	Limit switches LS-2 or LS-3 are not being operated. When the pusher reaches the end of its stroke (LS-3 for a short stroke, LS-2 for a long stroke) the Pusher will automatically retract when in the Automatic Mode. The limit switches are operated by contact with the Pusher frame. When the Pusher is operated in the Manual Mode it can be extended until it activates LS-2.	Use the Limit Switch Diagnostic to verify that the limit switches are making contact with the Pusher frame and that the controller is receiving the signal at the appropriate time.
	Solenoid valves #6 and #27 may not be operating properly. To retract the Pusher solenoid valve #6 should be supplied voltage and #27 should not be supplied voltage.	Verify that the valves are receiving voltage from the controller and to the solenoid valves. This can be done by retracting the Pusher in the Manual Mode.
	There is an obstruction in the way of the Pusher. The Over Cycle Time indication sequence will flash on the Indicator Lights if the retract time requires more than 4 seconds.	Check for obstructions that would keep the Pusher from retracting. This could be a rolled bale on the Load Bed.
Pusher extends too soon and bales are cut off at entry to the Bale Table.	Pusher delay limit switches LS-9, LS-14 are faulty. These switches signal to the control system that the Pusher can extend once these switches are released.	Use the Limit Switch Diagnostic to verify that the controller is receiving the signal from the limit switches at the appropriate time.
	Bale length is too long. Space is limited on the Bale Table. Excessive bale length may cause a bale to protrude into the entry of the Bale Table.	Correct the length of the bales so that they meet the range of bale length required by this bale wagon.
	The Bale Table Chain speed is too slow. The speed of the Table Chain on the Upper Elevator must be fast enough to allow the bale to enter the Bale Table area before the Pusher begins to operate. The Pusher will operate as soon as the limit switch conditions are met.	Increase the speed of the Bale Table (see "Hydraulic System Valve Setting Procedure" on page 42).
Pusher Operates but Tie Arms do not.	Tie Arm linkage is faulty. The Tie Arms are attached to shafts which are attached to a hydraulic cylinder.	Inspect the Tie Arm mechanical linkage and verify that the Tie Arms are properly seated into the shafts and that the keys and nuts are in place and tight.
	Valve #32 is not receiving voltage. Valve #32 requires voltage to direct flow to the Tie Arm cylinder in the hydraulic circuit.	Manually operate valve #32 to verify that the controller and wiring is delivering voltage to solenoid valve #32 (see "Solenoid Valve Diagnostics" on page 29).



Symptom	Problem	Solution
Pusher operates slowly or stalls, tie arms operate normally.	The pressure setting on the sequence valve #28 is faulty or set too high. The sequence valve allows the Pusher to operate only after the Tie Arms have extended. If the valve sticks or is set too high the Tie Arms will extend but the Pusher will struggle to extend or not extend at all. If the sequence pressure on the sequence valve #28 is set above the main system relief valve #17 then the fluid will bypass through valve #17.	Check the pressure setting of the sequence valve #28 (see “Hydraulic System Valve Setting Procedure” on page 42).
Tie Arms fail to extend fully before Pusher extends.	Pressure setting on the sequence valve #28 is too low. The sequence valve, when set properly, allows the Tie Arms to extend before the Pusher begins to extend. The sequence valve works by first requiring the Tie Arm cylinder to build to a certain pressure before activating the sequence valve and directing hydraulic fluid to the Pusher cylinder.	Check the pressure setting of the sequence valve #28 (see “Hydraulic System Valve Setting Procedure” on page 42).
Tie Arms fail to return when Pusher returns.	The Tie Arm Linkage is faulty. The Tie Arms are activated by a linkage which has a series of adjustments and fasteners that keep it together and allow it to work. The Tie Arms are connected to tapered shafts with a key and nut.	Check the linkage to make sure the fasteners and keys are in place and tight.
	The counterbalance valve #29 is set too low. The counterbalance valve #29 when set properly requires the hydraulic circuit to the rod end of the Tie Arm and Pusher cylinders to build to a certain pressure before the counterbalance valve opens and allows the fluid on the butt end of the Pusher cylinder to drain which allows the Pusher cylinder to retract. If this valve is set too low the pressure will not build up high enough to retract the Tie Arms and this allows the Pusher to retract before the Tie Arms are fully retracted.	Check the pressure setting on the counterbalance valve #29 (see “Hydraulic System Valve Setting Procedure” on page 42).

Symptom	Problem	Solution
<p>Load Bed will not index down when in the Automatic Mode and the pattern is complete.</p> <p>Continued....</p> <p><b>Note: If the Load Bed is being commanded to lower as part of the indexing when in the Automatic Mode and LS-7 is not activated within 4 seconds the Over Cycle Time Diagnostic condition will occur and the Load Bed will continue to lower until LS-12 or LS-10 are activated. When LS-7 or LS-12 is activated this will reset the Indicator Lights and turn them all off in preparation for the next pattern.</b></p>	<p>If the Over Cycle Time Diagnostic is not flashing:</p> <p>The conditions for indexing the Load Bed at the end of a pattern sequence are not correct. The Load Bed should index down when the current pattern has completed its last sequence and:</p> <ul style="list-style-type: none"> <li>- The Pusher has activated LS-4</li> <li>- LS-7, LS-10 and LS-12 are not activated</li> </ul> <p>If anyone of these conditions is not met the Load Bed will not index.</p>	<p>Check the position of all the limit switches involved in indexing the Load Bed. See "Limit Switch Diagnostics" on page 30 to determine the state of the limit switches.</p> <p>If the Load Bed did not index but the Indicator Lights reset and are all off then it is likely that limit switch LS-7 and or the mechanism is not properly activating or LS-12 is activated. When the Index Paddle is raised and no longer engages the limit switch LS-7, there should be no voltage signal to the controller.</p>
	<p>If the Over Cycle Time Diagnostic is flashing:</p> <p>Solenoid valve #11 is not receiving voltage. Solenoid valve #11 determines if the directional control valve will shift and allow hydraulic fluid to enter the Rod end of the Load Bed cylinder and allow the Load Bed to lower.</p>	<p>The command signal and wiring from the controller to the solenoid valve #11 can be checked. This can be done by manually operating the Load Bed from the Tractor Control Box while measuring the voltage to the solenoid valve to verify that the control voltage is being sent. It is also possible that the directional control valve #12 is sticking and not properly shifting.</p>
<p>Load Bed will not index down when in the Automatic Mode and the pattern is complete.</p> <p>Continued....</p>	<p>The solenoid valve #6 is receiving voltage causing the Pusher to operate but not the Load Bed. The solenoid valve #6 directs hydraulic fluid to the Pusher when activated and to the Load Bed and Bale Table Chain when not activated.</p>	<p>The command signal and wiring from the controller to the solenoid valve #6 can be checked. If there is voltage to solenoid valve #6, this could indicate that the pattern is not complete or there is an unexpected voltage to this solenoid from another source other than the controller. It is also possible that directional control valve #5 is sticking and not shifting.</p>
	<p>Counterbalance valve for the Load Bed Cylinder circuit is faulty. The counterbalance valve allows the Load Bed to smoothly lower regardless of the weight of the stack.</p>	<p>The counterbalance valve setting should be checked (see "Hydraulic System Valve Setting Procedure" on page 42).</p>

Symptom	Problem	Solution
Load Push Off will not operate.	The Bale Retainer Limit Switch LS-10 is not activating or is faulty. Limit switch LS-10 must be activated and the controller receive a voltage signal from it before the program will allow the solenoid valves #14 (extend) and #16 (retract) to operate. The Bale Retainer activates the LS-10 when it is raised. The raising of the Bale Retainer occurs hydraulically when the Load Bed cylinder is fully retracted.	The operation of limit switch LS-10 can be checked using the Limit Switch Diagnostic Mode (see page 30). Limit switch LS-10 should be activated when the Bale Retainer is fully raised. The mounting and the limit switch and the positioning of the limit switch arm can be adjusted so that it is activated by the Bale Retainer when fully raised.
	The Push Off mechanism is binding. The Push Off is driven by a chain which is powered by a hydraulic motor.	The Push Off Chain can be checked for binding or broken links. The hydraulic motor can be checked to verify it is rotating when commanded and that the pump is appropriately fixed to the Push Off Chain.
Load Bed will not raise.	Limit switch LS-11 is not operating properly. Limit switch LS-11 must be activated and the controller must receive a voltage signal before the program will allow the Load Bed to be raised.	The operation of limit switch LS-11 can be checked using the "Limit Switch Diagnostics" on page 30.
	The Load Bed Solenoid Valve #13 is not receiving a signal. Solenoid valve #13 directs the flow of hydraulic oil to the butt end of the Load Bed cylinder which allows it to extend and raise the Load Bed.	The command signal and wiring from the controller to the solenoid valve #13 can be checked. This can be done by manually operating the Load Bed from the Tractor Control Box while measuring the voltage to the solenoid valve to verify that the control voltage is being sent.
	The Load Bed switch LS-16 is not operating properly. If the controller receives a signal from LS-16, the controller will determine that the Load Bed is at its highest point of travel and the controller will not send a signal to LS-13 and the Load Bed Cylinder will not extend.	The operation of limit switch LS-16 can be checked using the "Limit Switch Diagnostics" on page 30.

# XA2 MODULE

## Error Codes, Messages and Actions

If one of the following errors is detected, a message will be presented on the display together with an error code on the module. In some cases, the module will turn off or at least shut down the outputs, to increase safety.

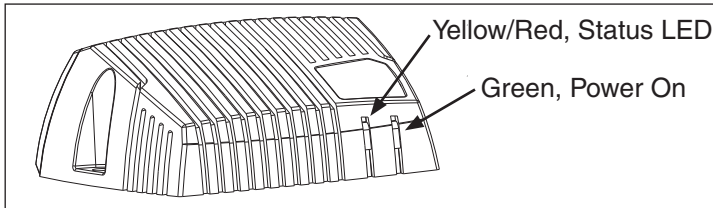

The location of the LED indicators on the IQAN-XA2 module.



**Do not operate the machine if an error message or error code is activated.**

LED indicator showing different XA2 modes			
Status		Flash	
Normal operation (yellow)			
Error Code	Error	Primary Flash (red) Error Category	Secondary Flash (yellow) Error Description
1:n	See note <sup>a</sup>		
2:n	See note <sup>a</sup>		
3:1	CAN error		
3:2	Address error		
4:1	Memory error <sup>b</sup>		
FE	Fatal error		

a. Error groups 1:n and 2:n are controlled by the master.

b. FRAM memory error.

# MC2 MODULE

## Error Codes, Messages and Actions

If one of the following errors is detected, a message will be presented on the display together with an error code on the module. In some cases, the module will turn off or at least shut down the outputs, to increase safety.

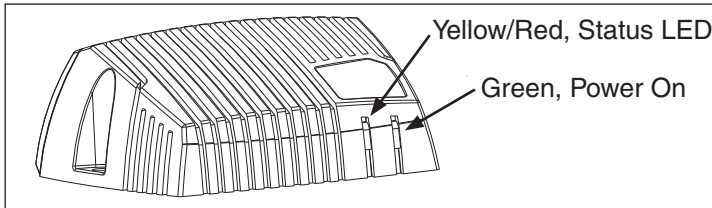

The location of the LED indicators on the IQAN-MC2 module.

WARNING

**Do not operate the machine if an error message or error code is activated.**

LED indicator showing different MC2 modes			
Status	Flash (yellow)		
Normal operation			
Application not loaded			
No application available			
Bad application			
Busy			
Error Code	Error	Primary Flash (red) Error Category	Secondary Flash (yellow) Error Description
1:1	Output		
1:2	Input		
1:3	Vref		
2:1	Power Supply		
2:2	Temperature		
2:3	Clock		
3:1	CAN error		
3:2	Address error		
4:1	Internal error		
SCS	Safe Crash State		

---

**INTENTIONALLY LEFT BLANK**

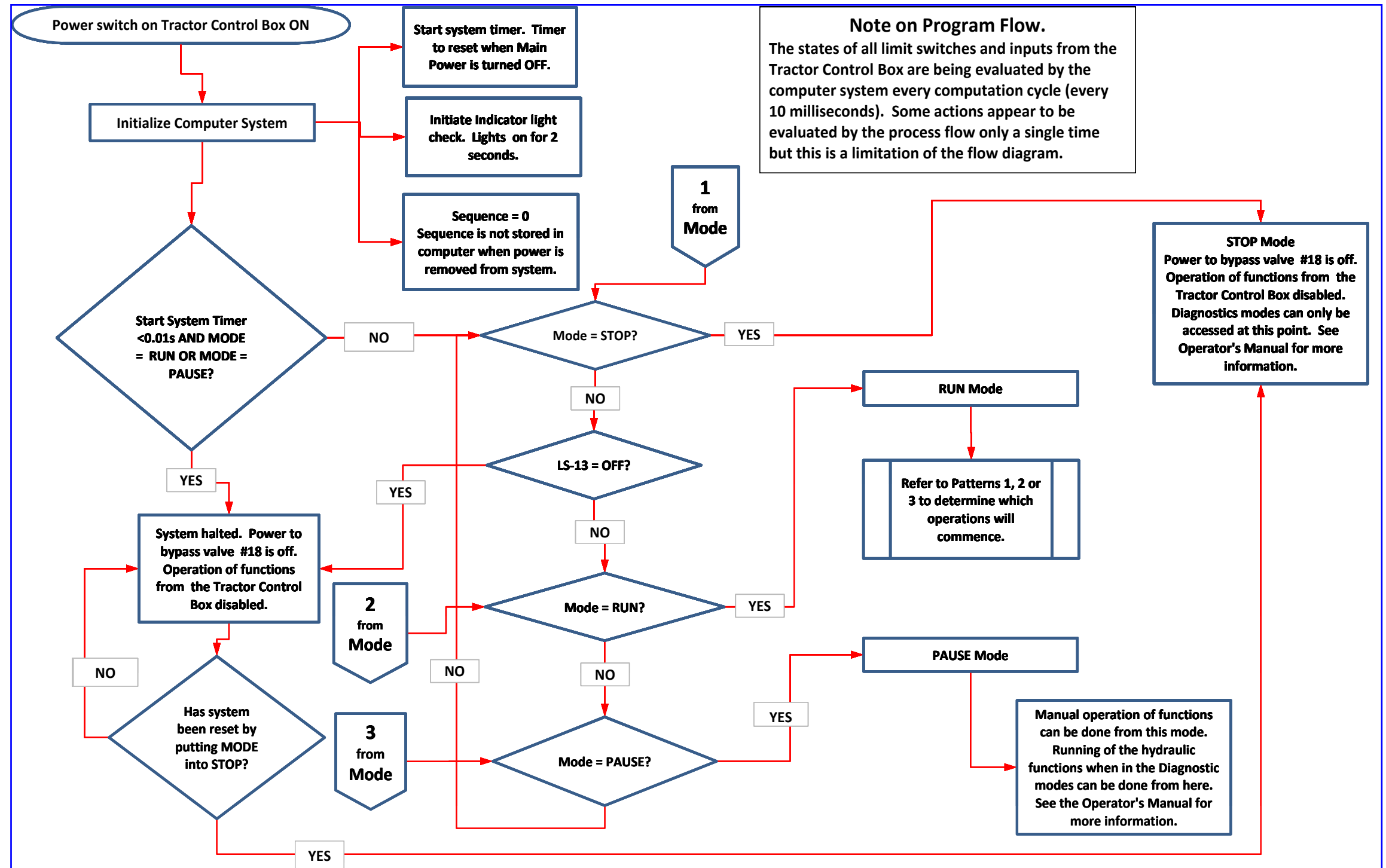
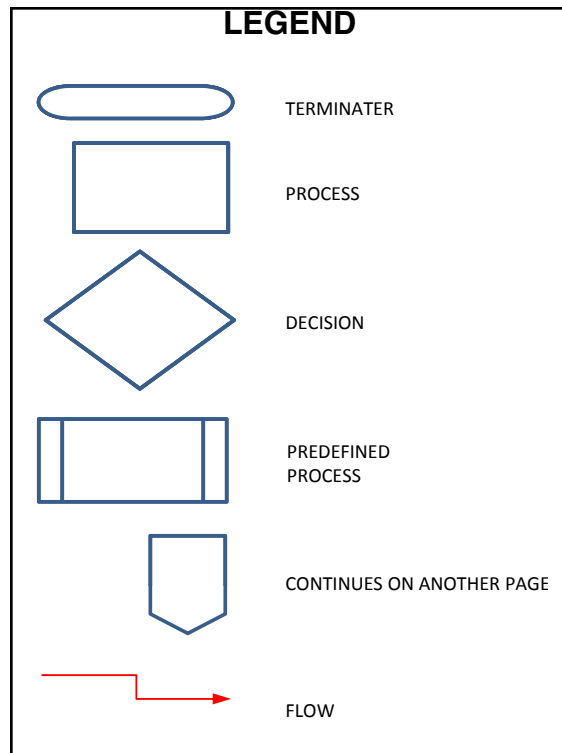

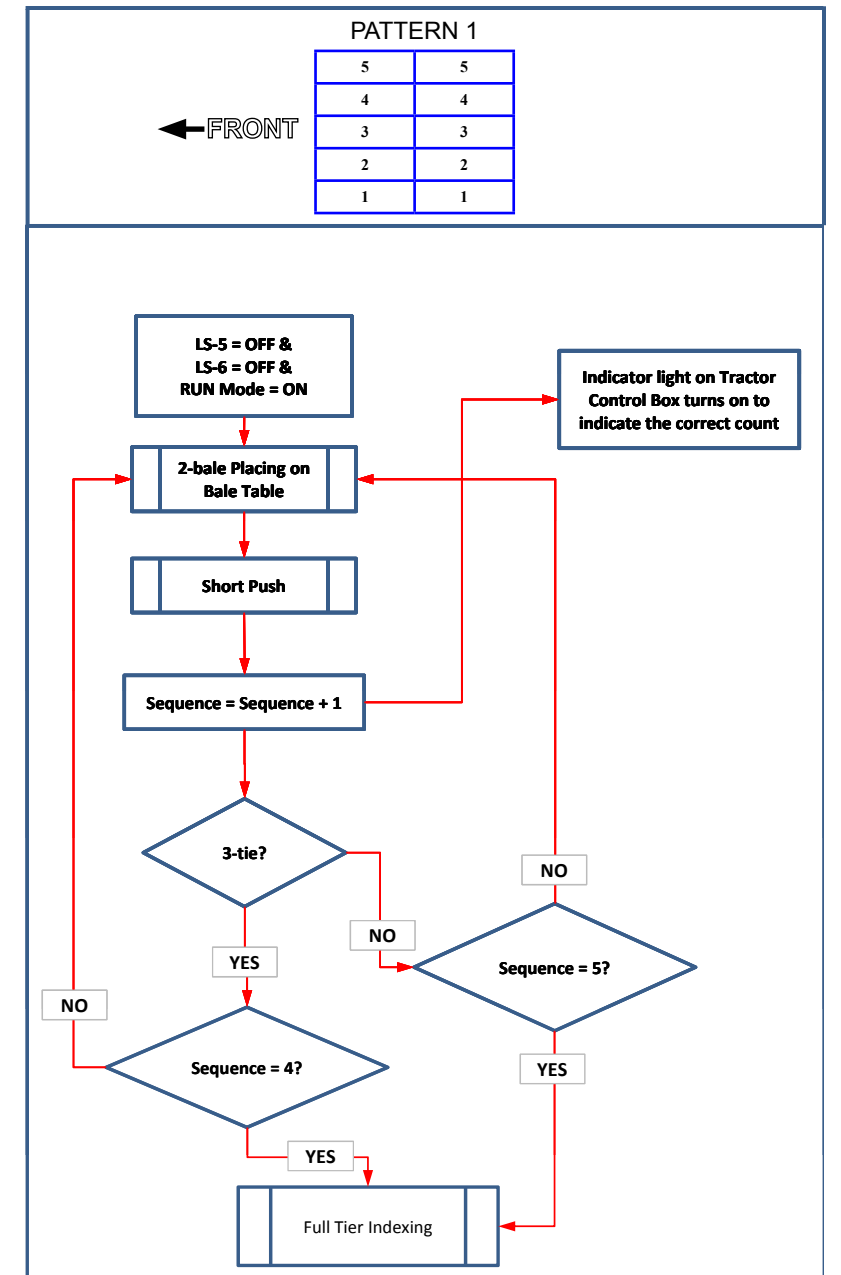
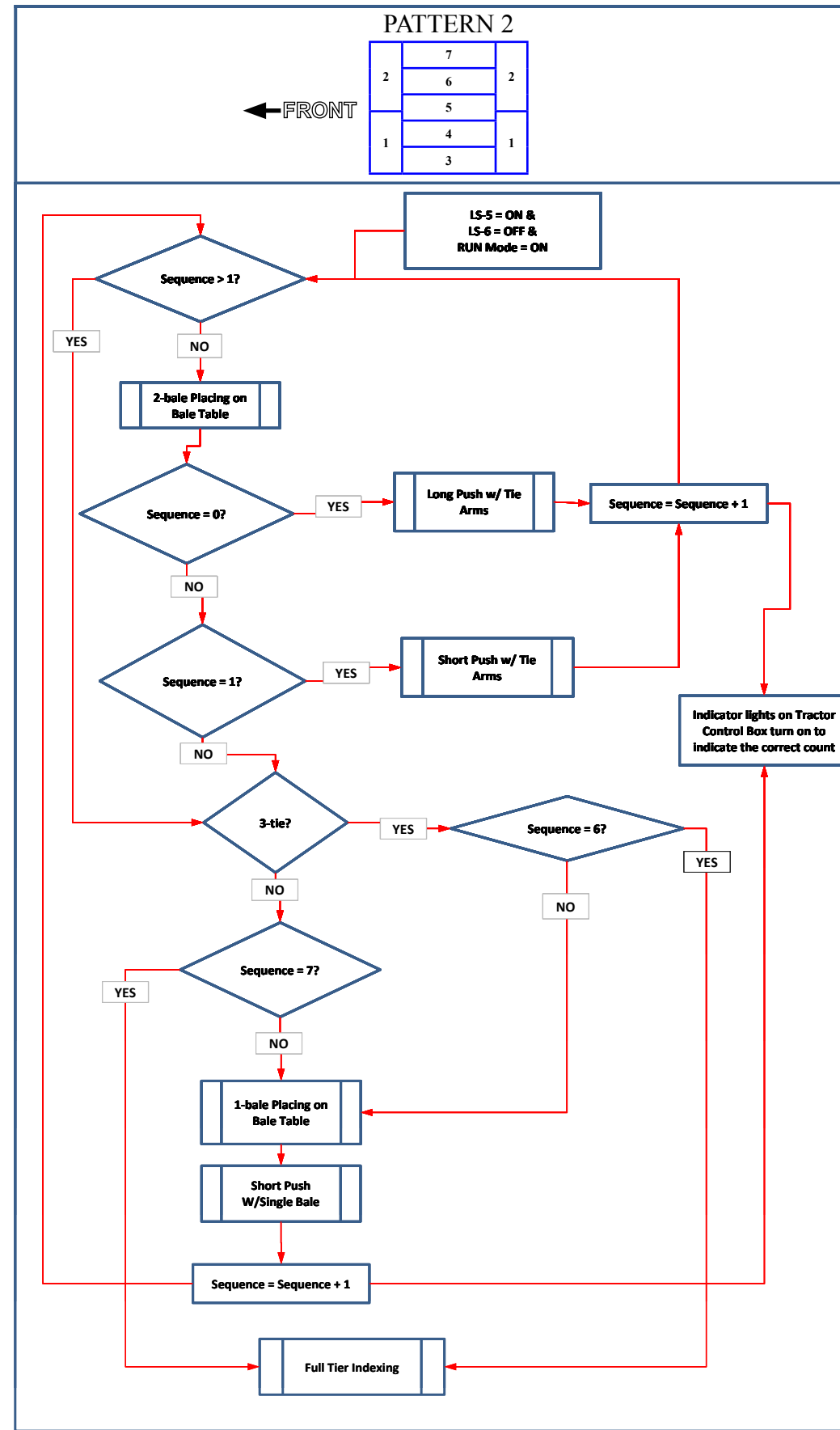
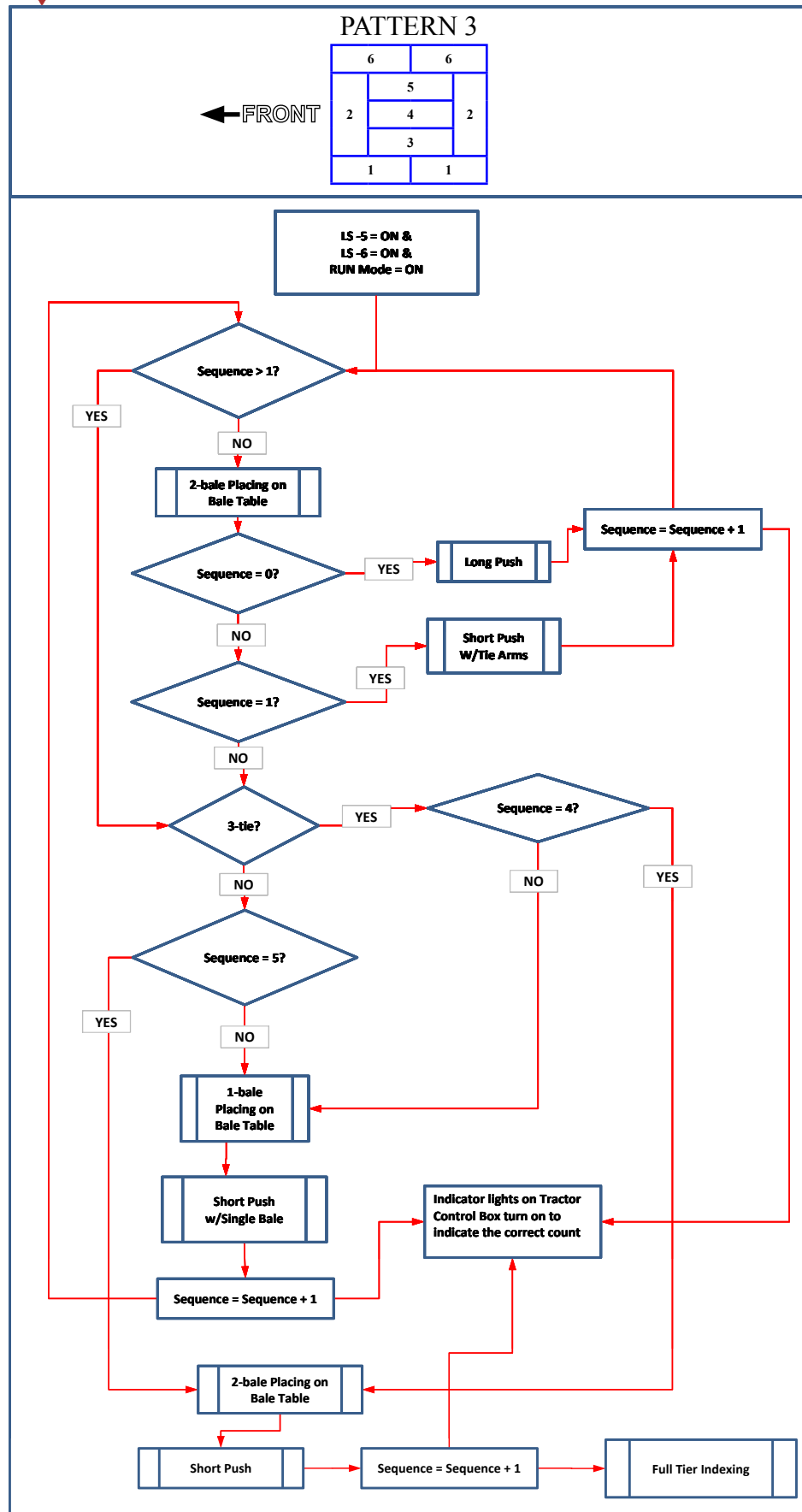



The green processes represent the inputs for the manual switches on the Tractor Control Box.

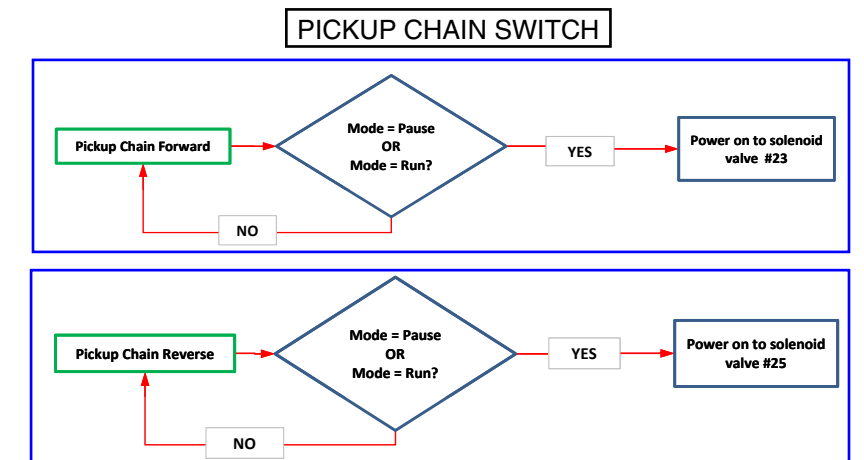
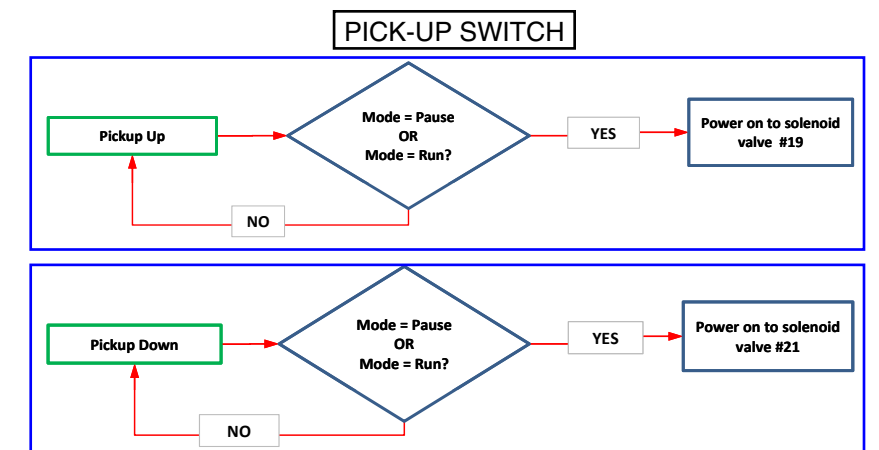
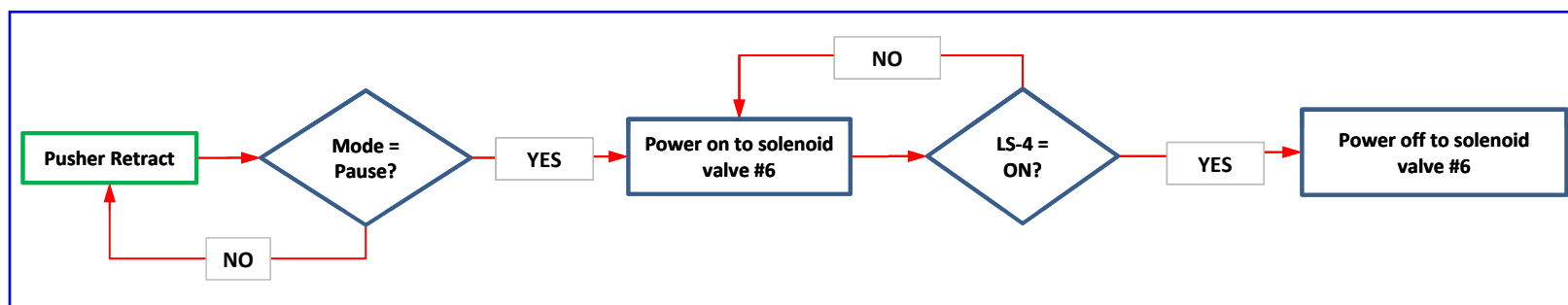
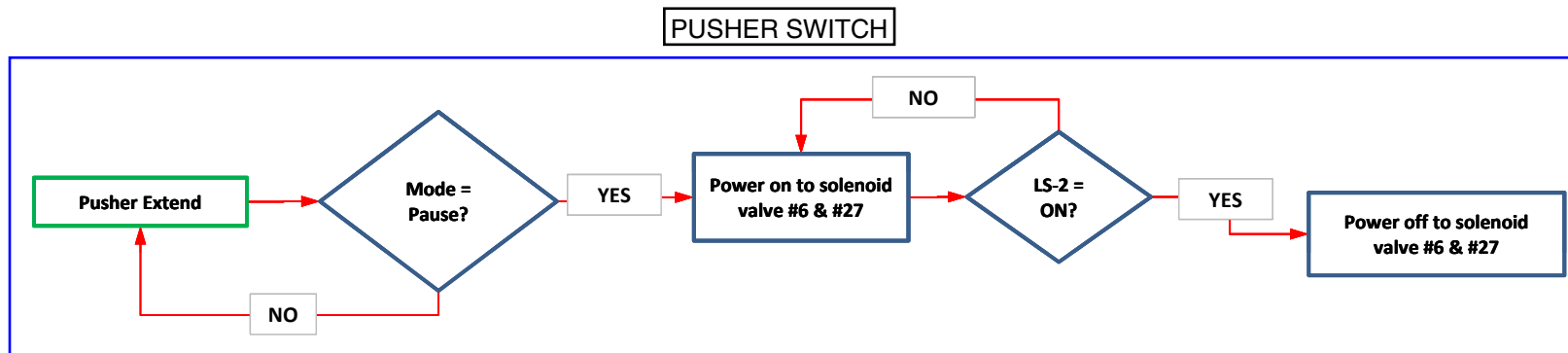
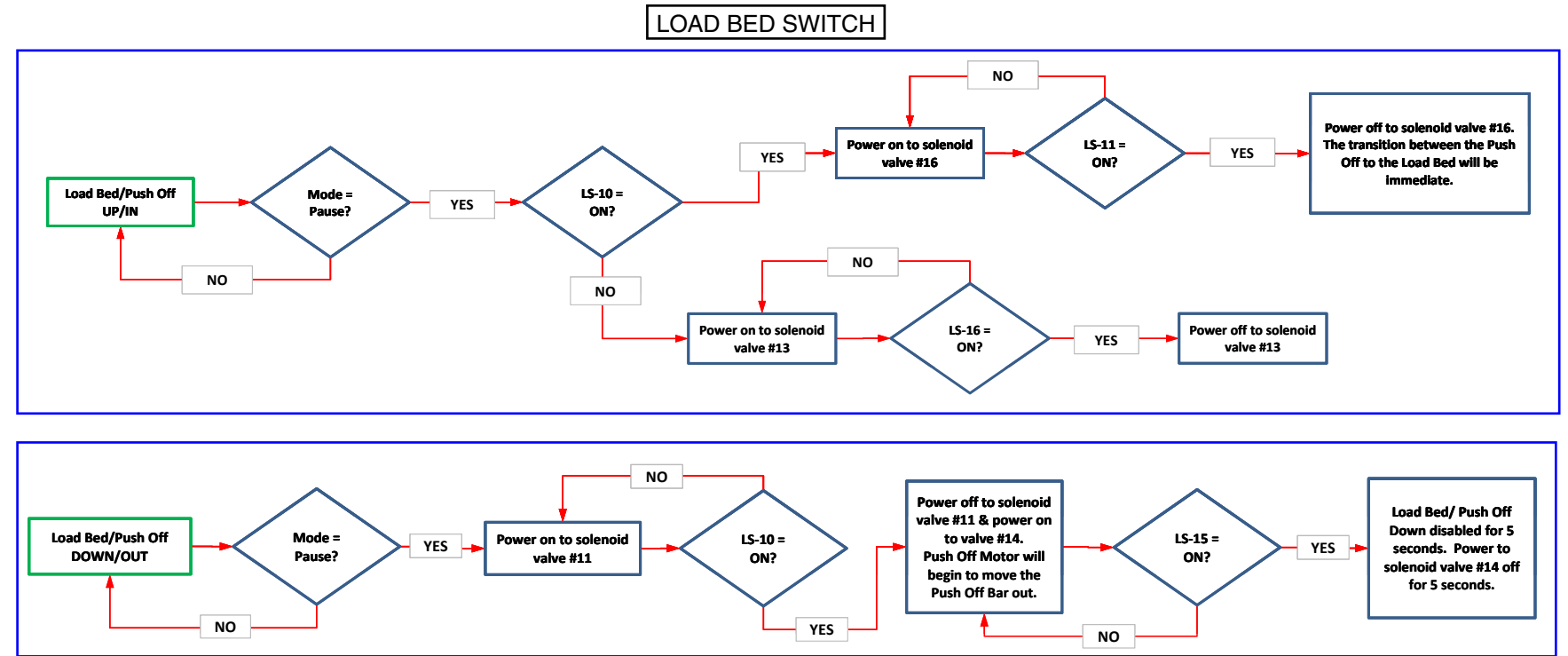
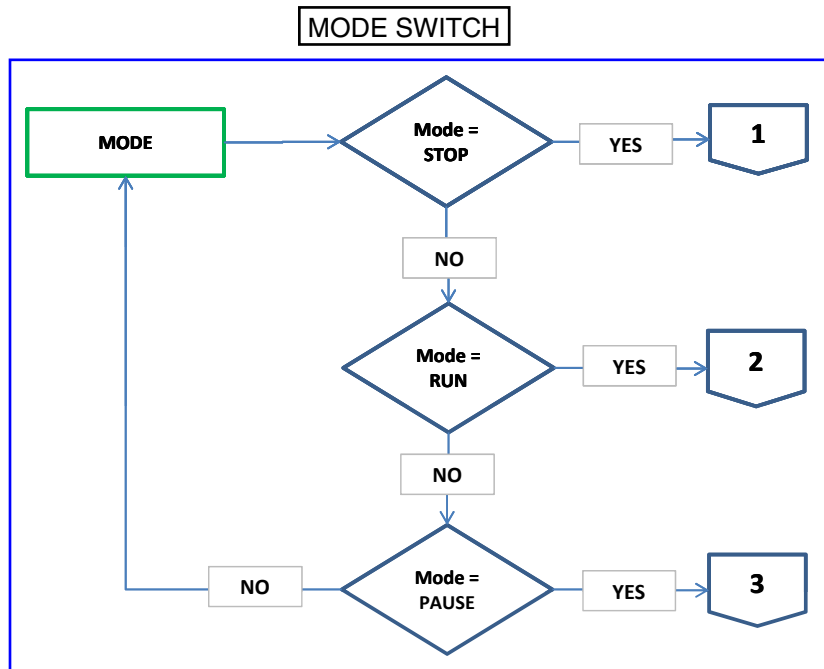

COUNT BUTTON

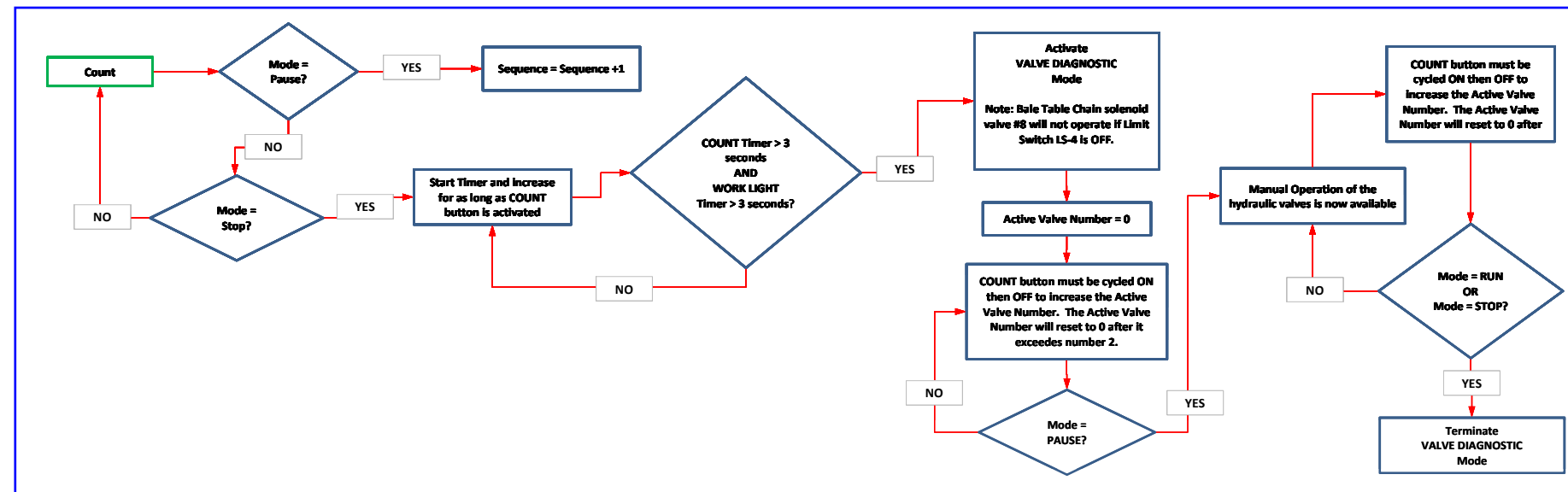

WORK LIGHTS BUTTON

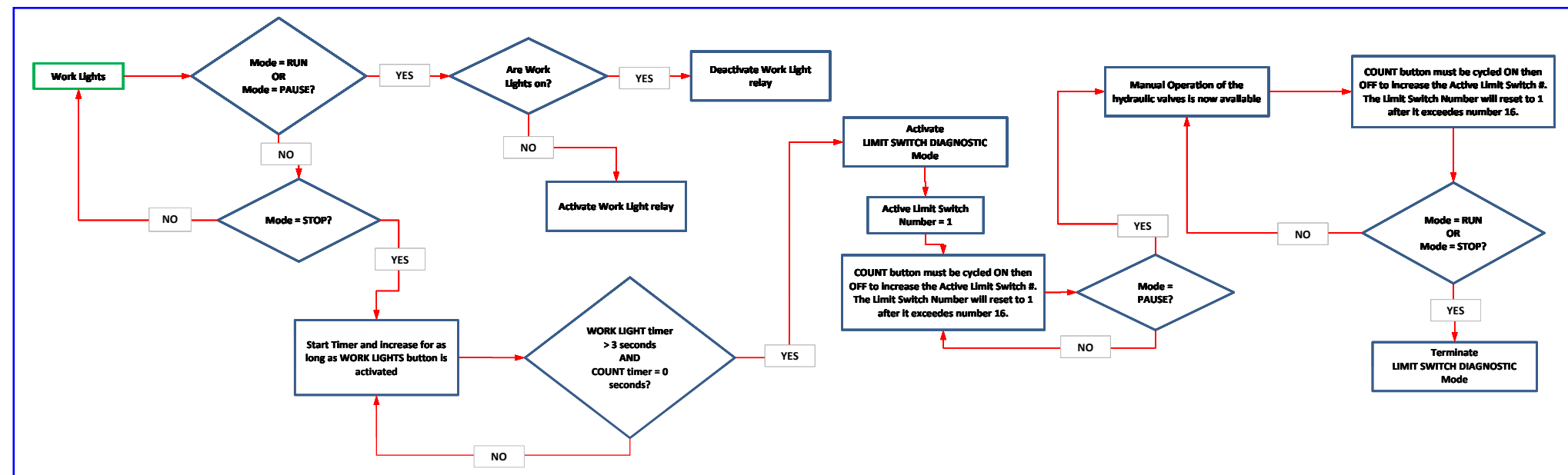

PICKUP CHAIN MOMENTARY FORWARD BUTTON

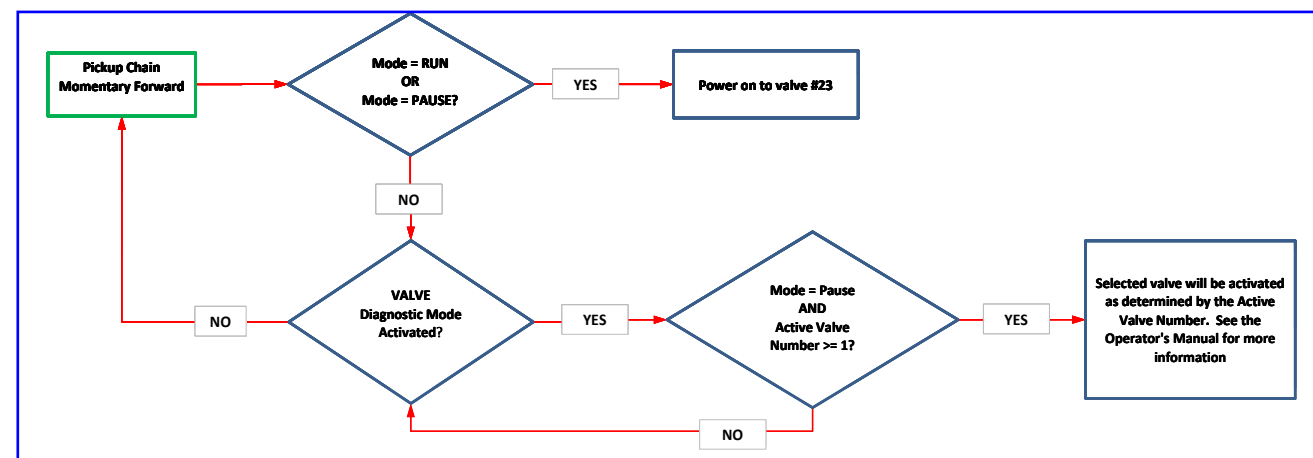

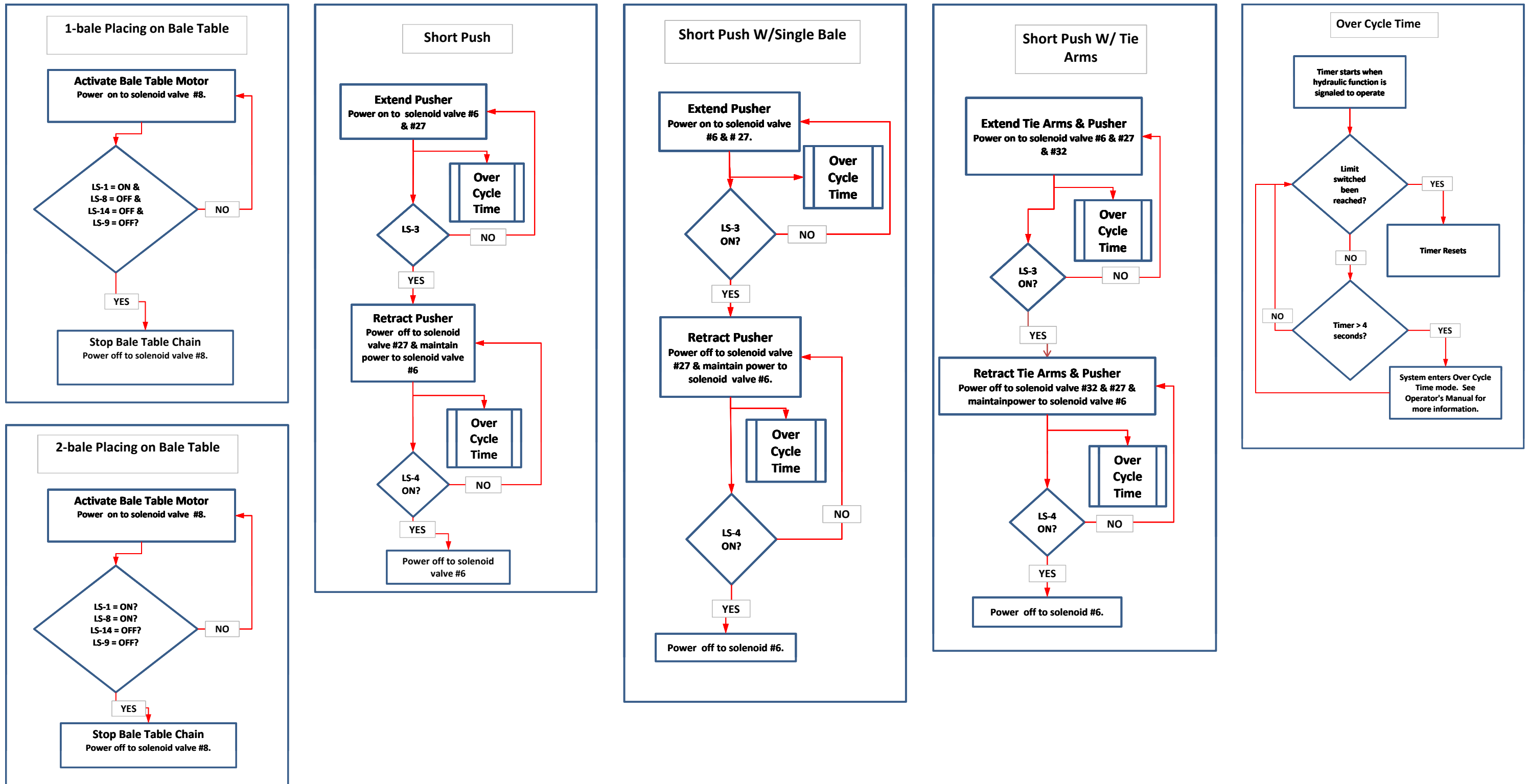

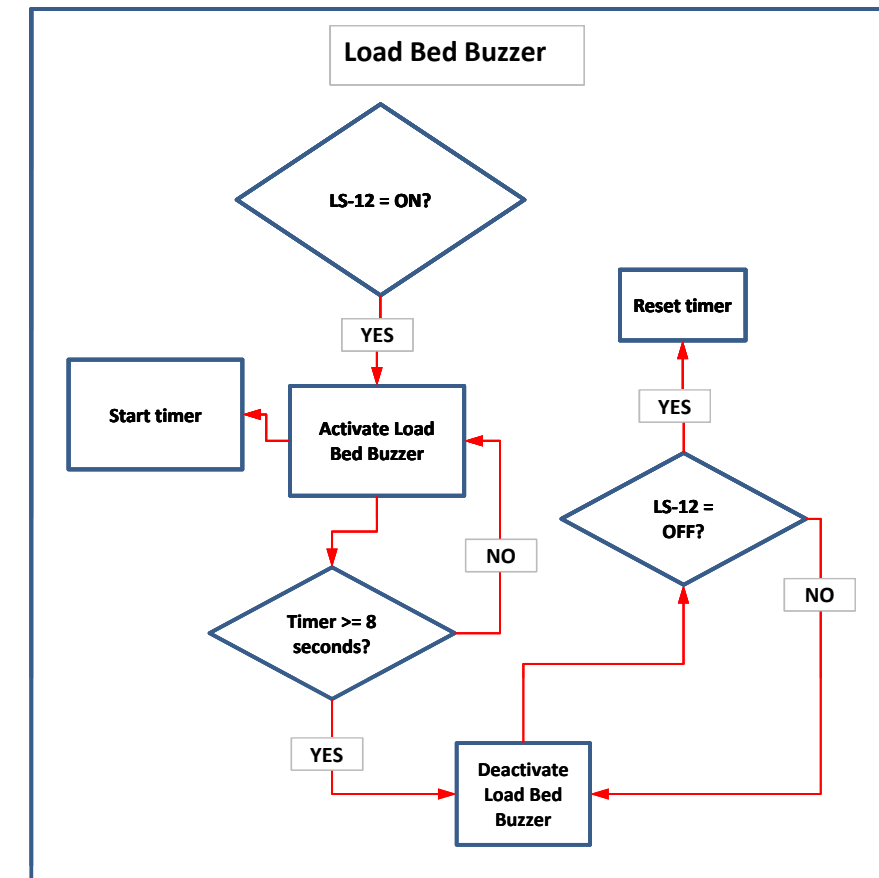
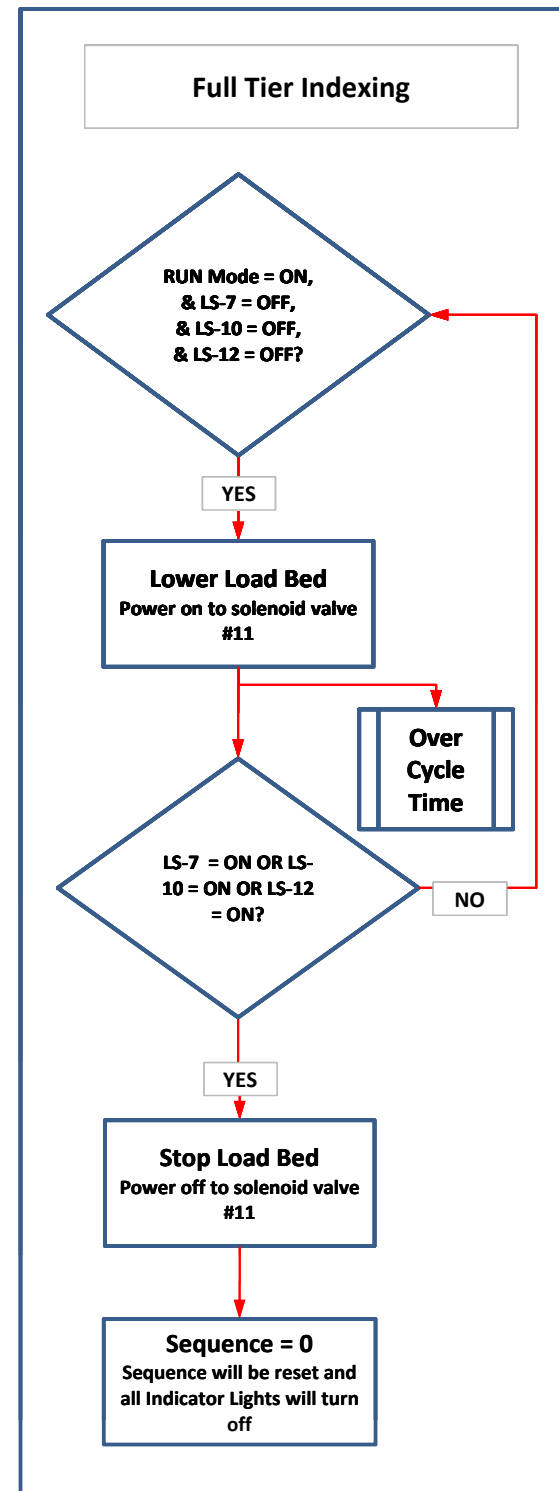
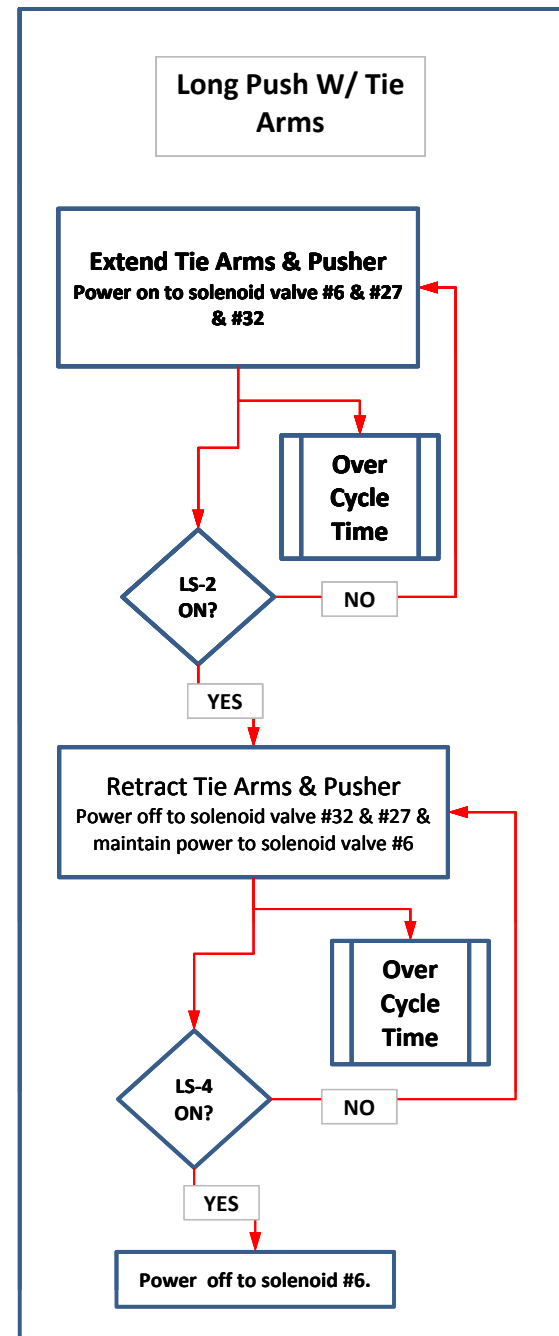
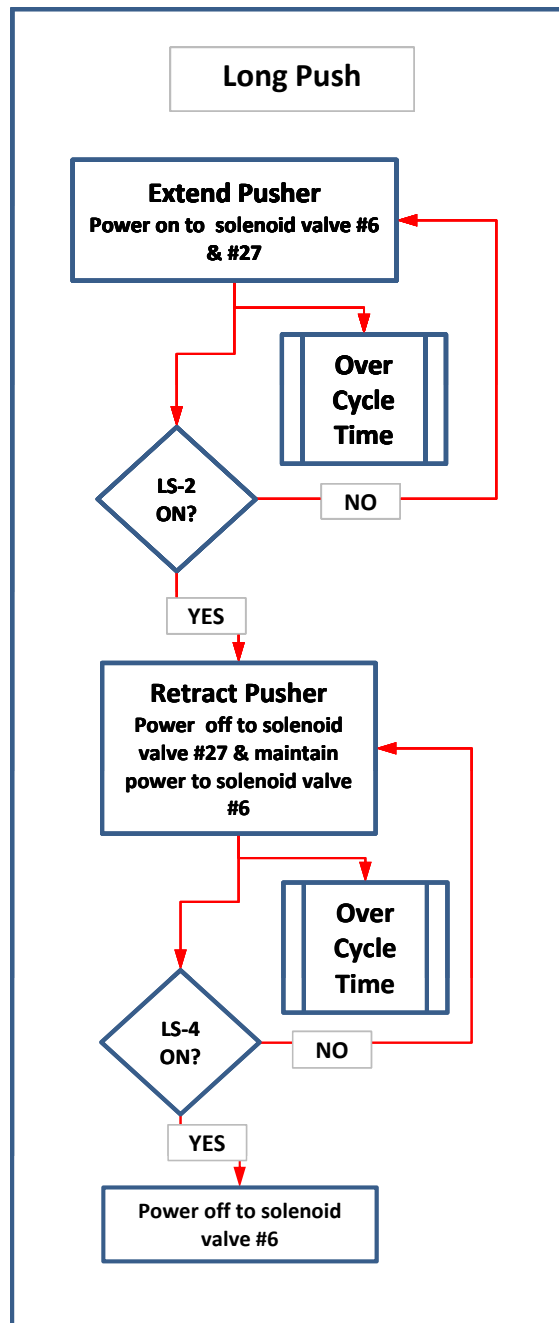

**INTENTIONALLY LEFT BLANK**



To find a dealer in your area,  
Call: 503-625-2560,  
Fax: 503-625-7269, or  
Visit our website: <http://www.alliedsystems.com>

**Allied Systems**  
C O M P A N Y

PB7000OP13 04/2016  
Printed in USA

---