

Operators Manual

Water Extractor

Model WE4

Starting in 2020, with
Serial Number: ASC-0WE4-466

A Product of

Allied Systems
COMPANY

Sherwood, Oregon USA

PB000WE4OPS66



Important: Be certain to specify the serial number of your Water Extractor when ordering parts.

This page is intentionally left blank.



WARNING

California Proposition 65 Warning

Diesel engine exhaust and some of its constituents are known to the State of California to cause cancer, birth defects, and other reproductive harm.

Battery posts, terminals and related accessories contain lead and lead compounds, chemicals known to the State of California to cause cancer, birth defects, and other reproductive harm. Wash hands after handling.

Other chemicals in this vehicle are also known to the State of California to cause cancer, birth defects, and other reproductive harm.

Safety

“THE BEST SAFETY DEVICE IS A CAREFUL OPERATOR”

Always turn off system control and Lock-Out the electrical supply to the machine before inspecting, adjusting or servicing the machine.

Do not clean, lubricate, or make any adjustments on the equipment while it is in operation.

Do not start the equipment until you are certain everyone is clear of the machine and have ensured there are no tools on the unit.

Do not work around equipment in loose clothing.

Do not attempt to service any equipment while the motor is running.

Inspection Covers and Safety Shields should only be removed by authorized service personnel.

After servicing do not place the equipment back into operation until all Safety Shields and Devices have been replaced. Operation without Safety Shields and Devices can place the operator into a hazardous situation.

Do not open or work on the In-Feed System until the flow of material has been stopped and the Motor is off.

Do not make any adjustments or reach under any load bearing surfaces while loaded.

INSTRUCT ALL OPERATORS ON SAFETY PRECAUTIONS.



WARNING: SOME ILLUSTRATIONS IN THIS MANUAL SHOW THE MACHINE WITHOUT SHIELDS TO ALLOW FOR A BETTER VIEW THE AREA BEING ADDRESSED. THE MACHINE SHOULD NEVER BE OPERATED WITH ANY OF THE SAFETY SHIELDS REMOVED.

General

The following pages contain general safety warnings which supplement specific warnings and cautions that can be found in the operators manual (PB0WE4AOPS66) that is included with this unit. All Freeman manuals can also be found online at www.alliedsystems.com. All electrical and hydraulic equipment is potentially hazardous. You must thoroughly review and understand this Safety Section before attempting to operate, troubleshoot, maintain or service this water extractor. Time, money and effort have been invested in making your Water extractor a safe product. The dividend from this investment is YOUR PERSONAL SAFETY.

However, it must be realized that no power-driven equipment can be any safer than the person behind the controls. If you don't operate and maintain your Freeman water extractor safely, our efforts will have been in vain.

The safety instructions and warnings, as documented in this manual and operators manual shipped with the machine, provide the most reliable procedures for the safe operation and maintenance of your water extractor. It's your responsibility to see that they are carried out.

Allied Systems Company cannot anticipate all worksite conditions, local regulations, etc. It is the responsibility of the end user to be aware of and obey any specific worksite, local, state, or national regulations or procedures that are applicable to operating this water extractor.

NOTE: All possible safety hazards cannot be anticipated so as to be included in this manual. Therefore, you must always be alert to potential hazards that could endanger personnel and/or damage the equipment.

Safety Symbols

The following symbols/terms are used to emphasize safety precautions and notices:



DANGER

The "DANGER" symbol indicates a hazardous situation which, if not avoided, will result in death or serious injury. Carefully read the message that follows to prevent serious injury or death.



WARNING

The "WARNING" symbol indicates a hazardous situation which, if not avoided, could result in death or serious injury. Carefully read the message that follows to prevent serious injury or death.



CAUTION

The "CAUTION" symbol indicates a hazardous situation which, if not avoided, could result in minor or moderate injury, or equipment damage. Carefully read the message that follows to prevent minor or moderate injury.

NOTICE

The "NOTICE" symbol alerts to a situation that is not related to personal injury but may cause equipment damage.

NOTE: ...

The term "NOTE" highlights operating procedures or practices that may improve equipment reliability and/or personnel performance, or to emphasize a concept.

Operation Warnings



WARNING

Warning: Failure to observe the following safety rules may result in extreme personal injury, dismemberment or death. It is the operator's responsibility to understand the proper and safe use of this water extractor.

Make sure that you read, understand, and obey all of the safety precautions and operating instructions in the operator's manual.

- Keep this Operator's Manual and the Safety Card (Allied form #89-120) with the water extractor at all times.
- Do not operate the water extractor unless you are authorized and trained to do so.

- Do not operate the water extractor if you are aware of any malfunctions, needed maintenance or repairs.
- Stop the water extractor immediately if any problems arise.
- Never operate the water extractor without all safety shielding in place.
- Keep hands, feet, hair, jewelry and clothing away from moving parts.
- Avoid wearing loose clothing which can easily be caught in moving parts.
- Know your job-site rules. Some have site-specific directions and procedures. The methods outlined in the operators manual provide a basis for safe operation of the water extractor. Because of special conditions, your company's procedures may be somewhat different from those shown in the operators manual.
- Do not start the water extractor if it has been marked with a "DO NOT START" or "RED" tag.
- Alert personnel in the area before starting the water extractor, and make sure everyone is clear.
- Each country has its own safety legislation. It is in the operator's own interest to be conversant with these regulations and to comply with them in full. This also applies to local bylaws and regulations in force on a particular worksite.
- Should the recommendations in this manual deviate from those in the user' country, the national regulations should be followed.
- Never attempt to disconnect any of the safety devices built into the water extractor.

Hydraulic Hazards

Be aware of the hazards of pressurized hydraulics:

- Wear personal protective equipment, such as gloves and safety glasses, whenever servicing or checking a hydraulic system.
- Assume that all hydraulic hoses and components are pressurized. Relieve all hydraulic pressure before disconnecting any hydraulic line.
- Never try to stop or check for a hydraulic leak with any part of your body; use a piece of cardboard to check for hydraulic leaks.
- Small hydraulic hose leaks are extremely dangerous, and can inject hydraulic oil under the skin, even through gloves.
- Infection is possible when hydraulic oil penetrates the skin. See a doctor immediately to prevent loss of limb or death.



Maintenance Safety

- Perform all routine maintenance outlined in this Operator's Manual in the time intervals indicated.
- Maintenance, lubrication and repair of this machine can be dangerous unless performed properly. In order to ensure safety, each person working on this water extractor must have the necessary skills, information, tools and equipment, and satisfy himself that his work method is safe, correct, and meets his own company's requirements.
- Do not attempt to make adjustments, or perform repairs unless you are authorized and qualified to do so.
- Never attempt to service energized equipment.
- Always shut off and secure power when servicing the water extractor.
- Disengage the water extractor and shut off power, and wait for all movement to stop before adjusting, lubricating, cleaning, or servicing the water extractor.
- Tag the Control Box with a "DO NOT START"(See Caution Statement on Page 10)
- Any unauthorized modifications made to the water extractor by the customer or parties other than Allied Systems will relieve Allied Systems Company and your Freeman dealer of any liability for damage or injury.
- Replace any worn parts only with genuine Freeman parts. Call your dealer for assistance.
- Unless specified in service procedures, never attempt maintenance or lubrication procedures while the water extractor operating.
- Before making adjustments to the electrical system, turn the power off.



Safety Equipment

- Ensure test equipment is in good condition.
- If an instrument must be held while taking measurements, ground the case of the instrument before energizing equipment.
- Do not touch live equipment or personnel working on live equipment while holding a multimeter. Some types of measuring devices should not be grounded—do not hold such devices while taking measurements.
- Prevent personal injury or equipment damage by using a lifting device with a lifting capacity greater than twice the weight of any equipment to be lifted.
- Always use personal protective equipment (PPE) appropriate to the situation. This may include the use of hearing protection, eye protection, a respirator, a hard hat, leather gloves, steel toed boots, etc.



Compressed Air Hazards

- When using compressed air to dry parts, pressure should not exceed 30 psi (200 kPa).
- Air pressure penetrating your skin can be fatal. Never direct compressed air at anyone.

Electrical Hazards

- An electric shock could be fatal. Ensure power to the water extractor is “OFF” before opening electrical panels.
- All electrical cables and connectors must be in good condition (free of corrosion, damage, etc). Use caution in wet weather to avoid danger from electrical shock. Never attempt electrical testing or repair while standing in water.
- Do not wear electrically conductive jewelry, clothing, or other items while working on the electrical system.



Table of Contents

Safety	2
Introduction	8
Serial Number Location and Baler Identification	9
Overview	10
Drawing's and Schematics	10
Dimensions / Weight	11
Lubrication	11
Setup	12
Mechanical Installation	12
Electrical Connection	12
Check Motor Rotation	12
Prime Pump	13
Connect Water Lines To Water Throttling Valve (if equipped)	13
Remove Metal Shipping Bracket On Float Level Switch	13
Connect Air Line to Air Nozzle On In-Feed Chute	14
Power Unit	14
Hydraulic Power Unit	14
Oil Types	14
Oil Level Float Switch	15
Dual Oil Temperature Switches	15
Oil Cooler / Oil To Water Heat Exchanger	15
Directional Control Valve	16
Hydraulic Pump Controls	16
Proportional Valve Manifold	16
Control Box	17

Table of Contents

Restriction System	18
Operation	19
Starting the WE-4	19
Turning off the WE-4	19
Emergency shut down	19
Automatic and Manual Operation	19
Auto Anti Plug	20
Plugging The Chamber	20
Operation Sequence	20
Adjustments	22
Potentiometer Adjustments	22
Level Detector Adjustments	23
Water Throttling Valve	24
Factory Settings	24
Maintenance	24
Unplugging/Anti-plug System	24
Safety Precautions	25
Maintenance Precautions	25
Reservoir Oil Level	25
Pump and Motor Coupler	26
Procedure To Fill an Empty Reservoir	26
Procedure to Add Oil to the Reservoir	26
To Change Oil and Clean a Reservoir	26
Flushing	26
Preventative Maintenance	27
Troubleshooting	28
Pump	28
Filter	31
Gauges	32
Machine Function	33

Introduction

Automated Water Extraction

The Freeman water extractor is an efficient, automated tool for extracting water from a continuously fed product. Product transport is eased with compaction and water removal. A wide variety of adjustments provide a machine to suit most products. The plunger forces water from the product. A restriction system is activated only when the plunger is advancing. A control box switch allows the restriction rail control system to be bypassed so that pressure is applied continuously for setting pressures, testing, and troubleshooting.

Serial Number Location

The serial number of your water extractor is necessary for correct ordering of replacement parts.

Replacement Parts

Genuine Freeman replacement parts should be used. Ensure prompt service by giving the dealer the part description and part number, model number, and serial number.

Appearance Care

To preserve the finish on Freeman equipment do not use abrasive heavy duty powders or solutions commonly used to clean solvent based paint finishes. Do not rub the finish with pads made of plastic or metal. These can scratch and dull the paint finish.

To clean the exterior and interior painted surfaces on Freeman equipment use trisodium phosphate (TSP). Any other cleaning agents should be spot tested.

Serial Number Location and Baler Identification

Each Freeman Water Extractor is identified by means of a model number and serial number. As a further identification, all power units are provided with a serial number.

To ensure prompt, efficient service when ordering parts or requesting repairs, record the serial numbers in the spaces provided.

WE-4 SERIAL NUMBER _____
Front side of main frame under motor.

POWER UNIT SERIAL NUMBER _____
Electric Motor- _____

NOTE: The motor and pump end is considered the front of the Water Extractor. The sides are described as left-hand side and right-hand side as viewed from the rear while facing the chamber.

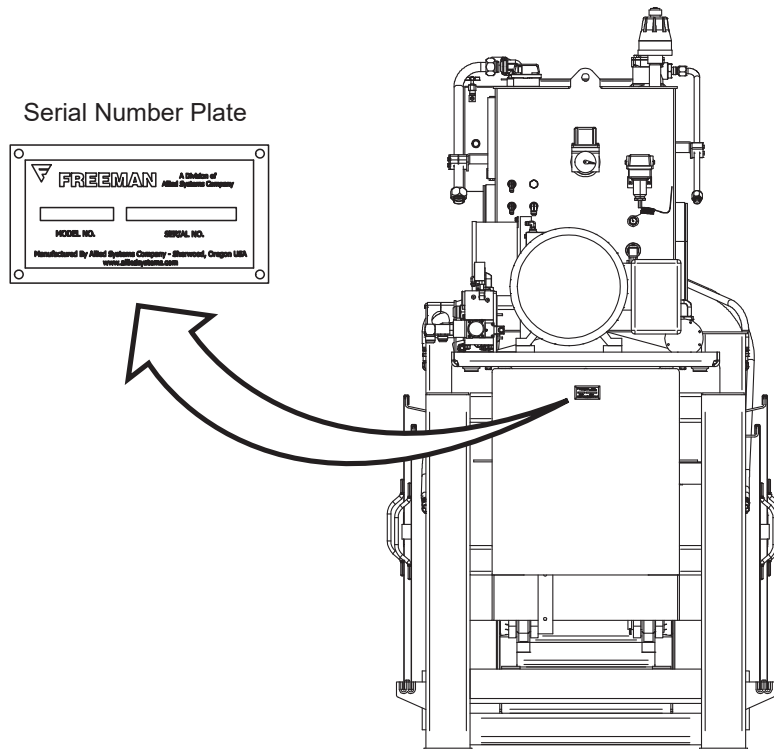

S/N Location starting with ASC-0WE4-466

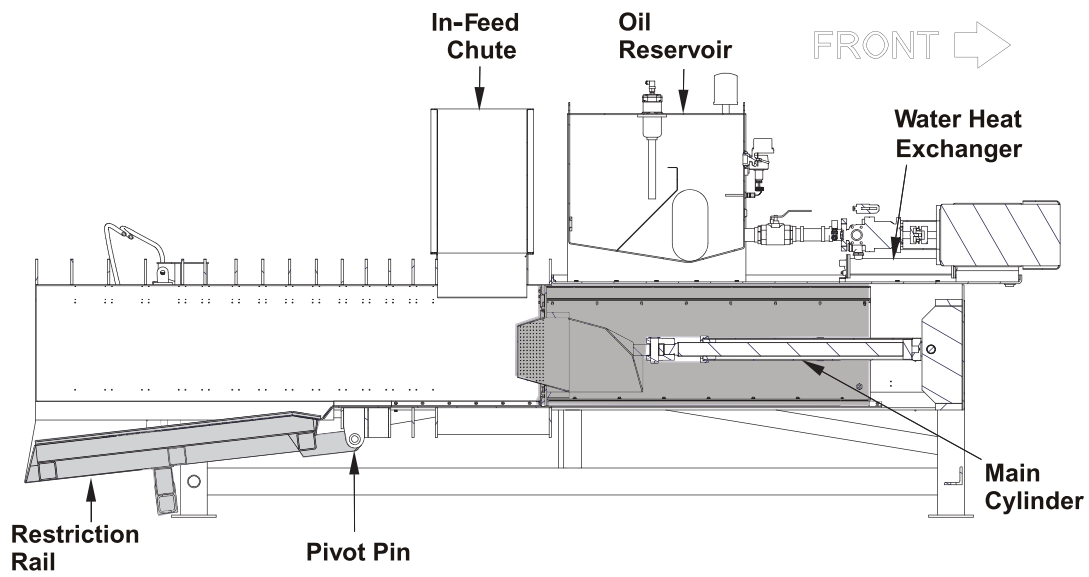

Figure 1. Right Side

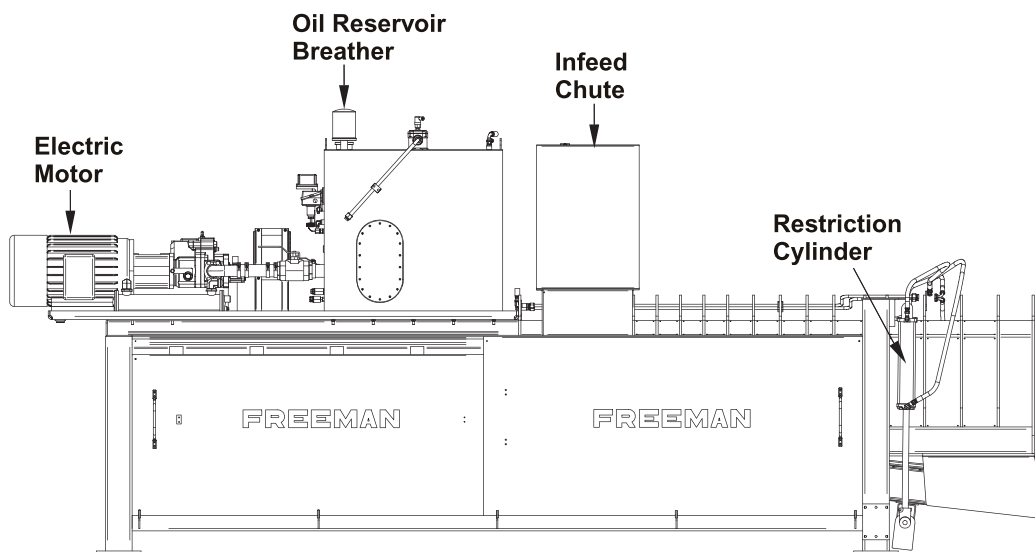

Figure 2. Left Side

Drawings, Parts, and Schematics referenced throughout the manual:

- 905505.....Hydraulic Schematic
 - 910504.....Wiring Diagram Junction Box
 - 910496.....Wiring Diagram Control Panel (IQAN)
- (All Drawings can be found in the document pack shipped with this model.)

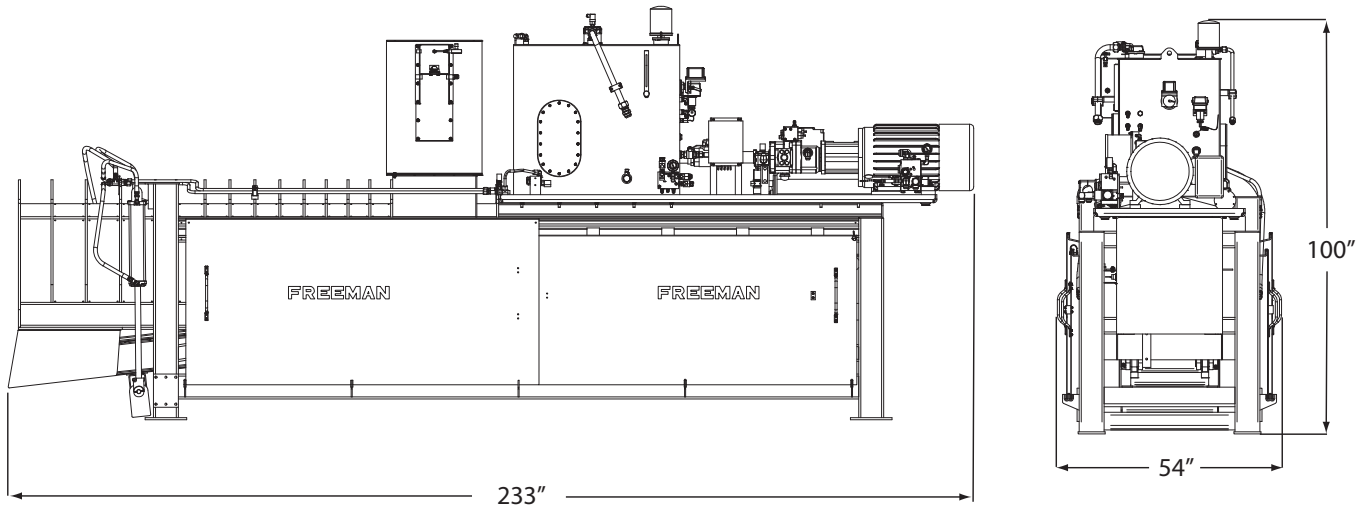

Figure 3. Dimensions

Dimensions / Weight

Length:..... 20'
 Height: 9'-9"
 Width: 6'
 Weight: Approximately 9,700 Lbs With Oil

Restriction Rail To Ground Fully Open: 9"
 Motor: 40 hp/460 Volt

Chamber Width..... 24"
 Chamber Height 27"
 Plunger Stroke Length..... 42"
 In-Feed Opening: 20" x 20"

Volume..... 4000 Cubic Feet/Hr at 8 Strokes/Min.

Lubrication

Hydraulic Oil: Mobil 424 or Mobil DTE 15M or equivalent to a Viscosity greater than 10 centistokes at 180°F and less than 200 centistokes at 60°F.

Hydraulic Reservoir Capacity: 110 Gallon
 Check Oil level:..... Daily
 Change Return Line Filter: Every 6 Months
 Test Oil:..... Every 6 months and change accordingly
 Change Oil:..... *Annually if oil isn't being tested
 Change Breather Filter: Every 6 Months
 Grease Electric Motor:..... See Manufactures Manual

* Contact Freeman Service Department for Recommendations on oil testing kits.

Setup



Always turn off system control and lockout the electrical supply to the machine before inspecting, adjusting or servicing the machine.

Mechanical Installation

Anchor the base The water extractor location should allow efficient joining to the In-Feed chute, and provide personal safety. Provide adequate space for servicing. Locate the discharge so the product discharge falls free, with no backup of the product.

The water extractor should be located within a catchment to provide for water retention and water spray drainage. Use sixteen, grade 8, 3/4 inch bolts through the foot pads to anchor the water extractor to a foundation of concrete or steel. Use shims to provide a level surface.

Electrical Connection

Power unit connection The 40 horsepower motor operates at 460 volts. Supply wires should be correctly sized to prevent the motor from stalling during machine operation and momentary overloads and meet all relevant electrical codes and practices. See wiring diagram 910496.

Main Control Panel The Oil Level Sensor, Oil Temperature Sensor, Motor Starters (supplied by others), and HPU mounted Junction Box are to be wired by the customer upon installation and must meet all relevant electrical codes and practices. See wiring diagram 910496.

Check Motor Rotation

IMPORTANT: Open up suction valves (see Figure 6 - pg. 13) so the hydraulic pump is flooded with oil before turning on the motor (see Prime Pump section - pg. 13).

Move the SYSTEM CNTRL Switch to STOP, RESTRICTION Switch to AUTO, and ANTI-PLUG switch to AUTO (see Figure 4). Remove the motor-pump coupler cover at the right side for viewing. Jog the motor to check for correct rotation. Note the motor shaft direction of rotation (standing at the front of the WE-4 viewing the motor). Correct rotation is clockwise (see Figure 5). Replace the cover.

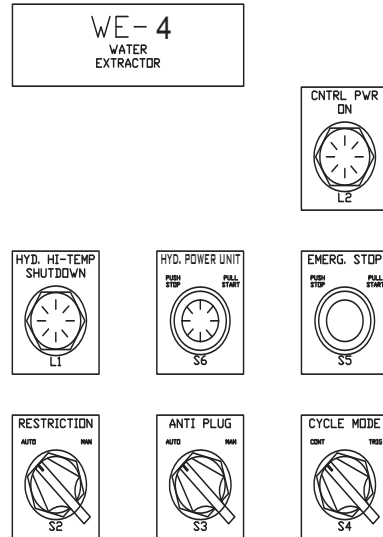

Figure 4 - Control Panel

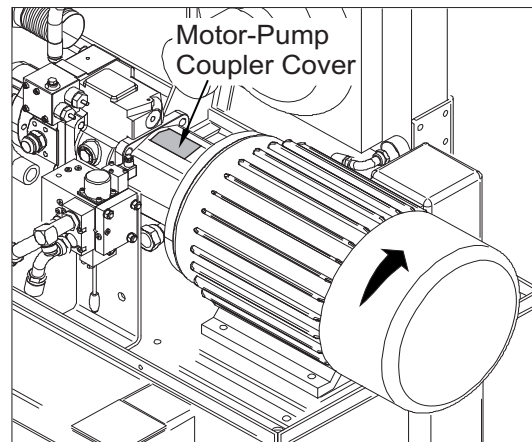

Figure 5 - Correct motor rotation

Motor power must be supplied through an external motor branch circuit disconnect and magnetic starter, incorporating a motor overload disconnect device. The motor branch circuit disconnect should have excess current prevention devices meeting the National Electric Code Table 430-152. Overload disconnects should be set to the motors full load current rating.

Emergency motor stop and low oil shutdown The emergency motor stop switch and low oil shutdown float switch (see Figure 13 - Pg. 15) are connected to control box terminals(see wiring diagram 910496). Connect the motor starter power as shown on 910496 to place the switches in series with the motor control circuit.

Prime Pump

CAUTION

Always turn off system control and lockout the electrical supply to the machine before inspecting, adjusting or servicing the machine.

1. Make sure the pump case is filled with clean, filtered fluid identical to that used in the rest of the system (see Filter and Lubrication Pg.14). The pump case must be full at all times to ensure proper lubrication of internal components.
2. Verify that piping is completed and any inlet valves are open to prevent cavitation or aeration of the pump.
3. Confirm that the direction of rotation of the motor matches the pump installed (see Check Motor Rotation Pg.12).
4. Jog start the motor with the pump unloaded and operate until the air is bled from the system.
5. Check the pump for external leakage, abnormal noise, and vibration.

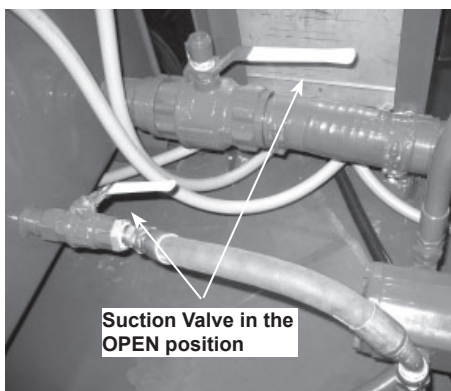

Figure 6 - Suction Valve

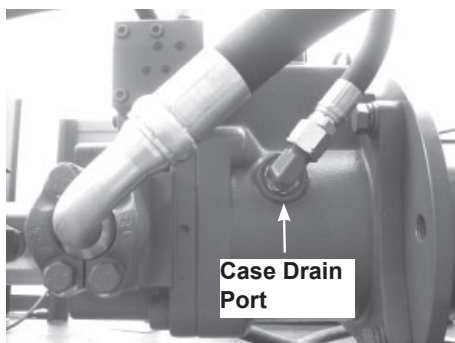

Figure 7 - Prime Pump Location

Connect Water Lines To Water Throttling Valve (if equipped)

A Water Throttling Valve is used with water extractors that are equipped with an Oil to Water Heat Exchanger. The throttling valve meters the flow of cooling water through the heat exchanger based on the temperature of the hydraulic oil. The valve is set to open when the oil temperature reaches 130°F (54 °C). See Pg.24 for adjusting Water Throttling Valve. Connect in-going water line (provided by others) to Water In port (Min. 5 GPM @ 75 °F (24 °C) maximum 150 psi, 25 GPM). Connect out-going water line to Water Out port (see Figure 8).

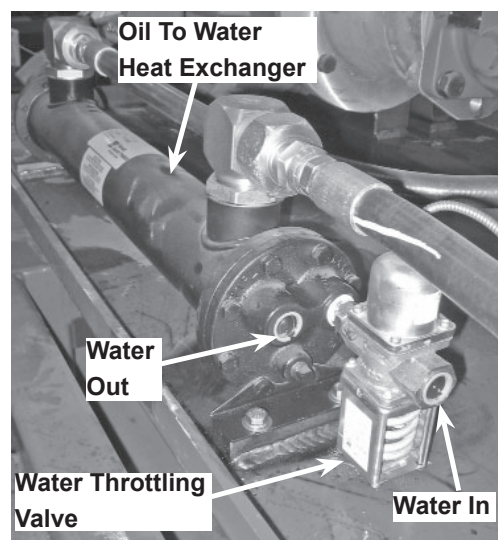

Figure 8 - Water Throttling Valve

Remove Metal Shipping Bracket on Float Level Switch

A metal bracket is installed on the Float Level Switch located on the Oil Reservoir (see Oil Level Float Switch) to prevent damage to the float during transport. Remove the bracket after installation (see Figure 9).



Figure 9 - Float Level Switch

Setup / Power Unit

Connect Air Line to Air Nozzle On In-Feed Chute

The Air Nozzle cleans the Plexiglas in front of Level Detector. This keeps the Level Detector accurate. Connect to a compressed air source (supplied by others) with 50 - 100 PSI and approximately 5 CFM.

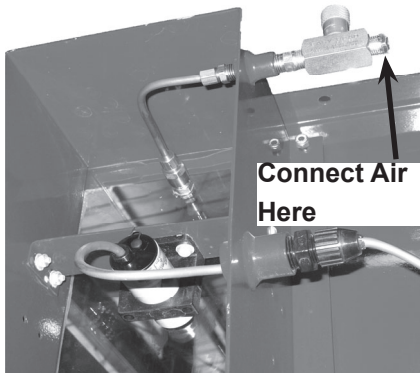

Figure 10 - Air Nozzle

Oil Types

Use one of the following recommended oil types:

Hydraulic Oil: Mobil 424 or Mobil DTE 15M or equivalent to a Viscosity greater than 10 centistokes at 180°F and less than 200 centistokes at 60°F.

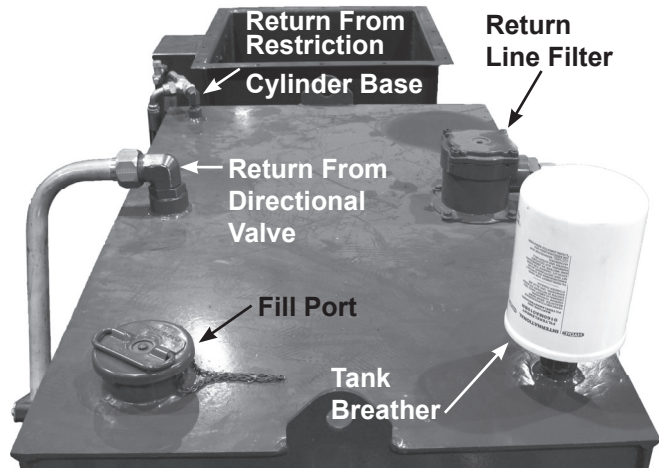

Figure 11 - Fill Port and Breather Cap

Hydraulic Power Unit

Check oil level Check the oil level gauge, which should be 1" to 2" below the HIGH mark with all 3 cylinders retracted and 2" to 3" below the High mark with all three cylinders extended (see Figure 12 and Figure 36 Pg. 25).

Filter and lubrication Dirt is an intolerable element in a hydraulic system. Your power unit is designed to preclude the introduction of external dirt into the system.

All new oil put into the system is added through a "Fill Port" (see Figure 11). To get from the fill port into the system, the oil must pass through the Fill Screen. This degree of filtration helps to reduce component wear within the system, resulting in improved system life.

The oil tank breather cap should be changed every six (6) months (see Figure 11).

Each time a new breather filter is installed please take the time to write the yearly replacement date on the unit with a black felt pen.

Reservoir capacity is 110 gallons. Oil change intervals vary according to actual operating conditions. The oil should be tested every six (6) months and changed accordingly. If not testing, under normal conditions the oil should be changed yearly.

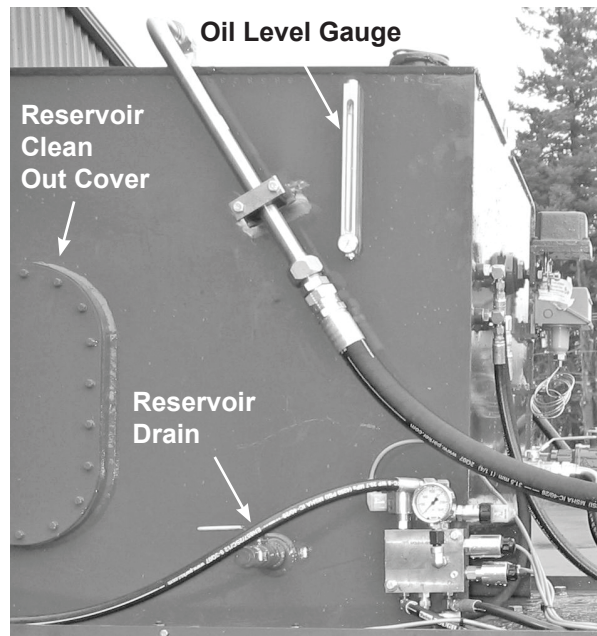

Figure 12 - Reservoir Drain

Oil Level Float Switch

An emergency low level float switch (see Figure 13) is installed to automatically stop the pump to protect it from damage in the event of line breakage or faulty maintenance. The low level float switch is connected (by others) as shown on wiring diagram 910496.

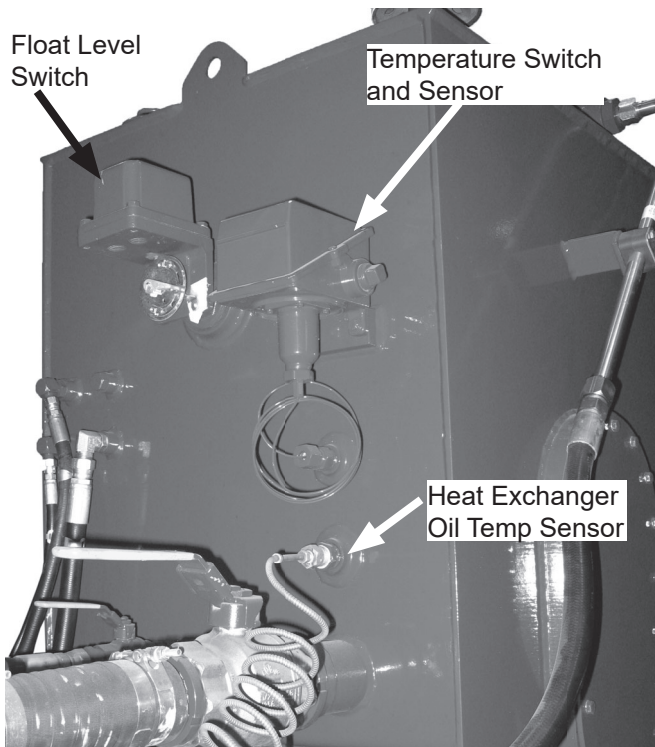

Figure 13 - Temperature and Float Level Switch

Dual Oil Temperature Switches

Dual Oil Temperature Switches are installed in the WE-4 system to prevent damage caused by high temperatures. Temperature switch Dial #2 set at 120°F (see Figure 14) turns the cooler fan motor on and off (if equipped). Dial #1 set at 180°F stops the pump motor at the high setting. The Oil Temperature Switch is connected (by others) as shown on wiring diagram 910496. See manufacturer's manual in your document pack for settings. Dial #3 is not used.

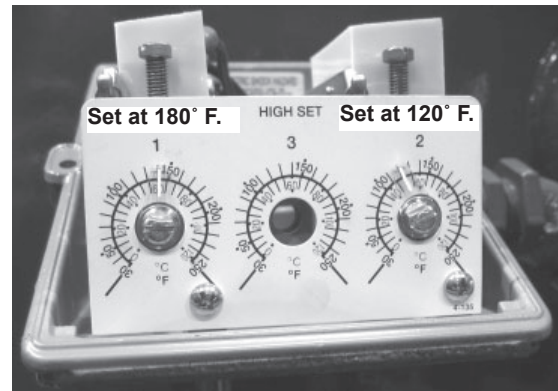

Figure 14 - Temperature Switch

Oil Cooler / Oil To Water Heat Exchanger

The Hydraulic system operates more accurately when the oil viscosity is consistent. Since oil viscosity varies with temperature, your power unit is equipped with an Oil Cooler (see Figure 15) or Oil to Water Heat Exchanger (see Figure 16) to automatically maintain the oil temperature from 130°F to 160°F.

The optional Oil Cooler uses the Temperature Switch sensor Shown in Figure 13. The Oil to Water Heat Exchanger uses the Sensing Bulb shown in Figure 13.

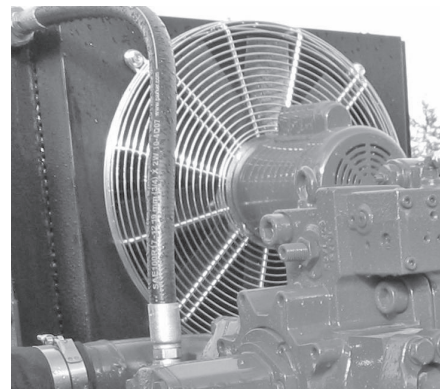

Figure 15 - Optional Oil Cooler

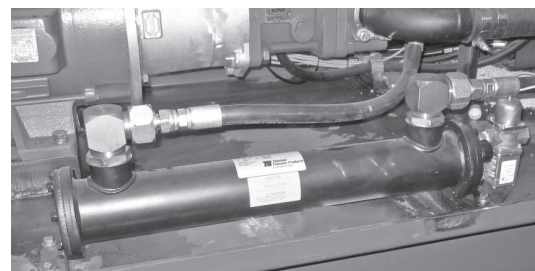

Figure 16 - Heat Exchanger

Power Unit

Directional Control Valve

Directional Control Valve is for controlling the direction of the plunger (see Manual Operation Pg. 19). The Main System Pressure gauge is located on the Directional Control Valve (see Figure 18). The Manual control Lever can also be used to relieve pressure in the plunger cylinder when the HPU is shut down.

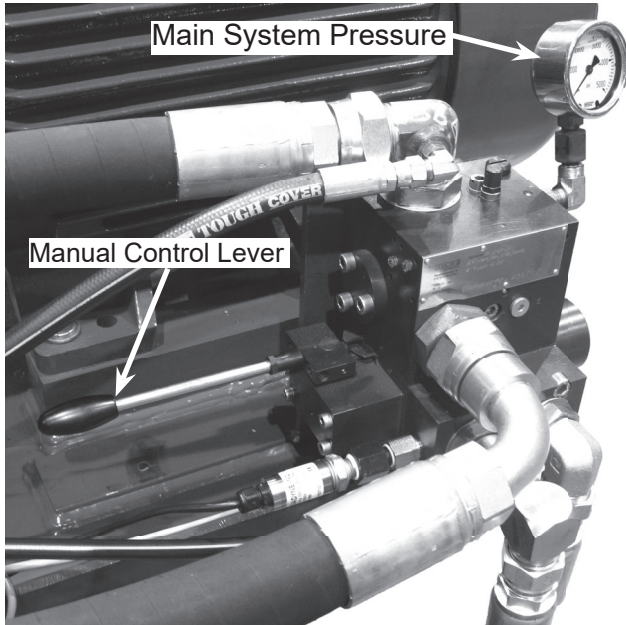

Figure 18 - Directional Valve

Hydraulic Pump Controls

The hydraulic pump has 3 different adjustments (Cut off Pressure, Differential Pressure and Torque Limit) and is pre-adjusted at the factory. **DO NOT** make any adjustments unless directed by the factory. Readjustment without the approval of Allied Systems Co. voids the warranty.

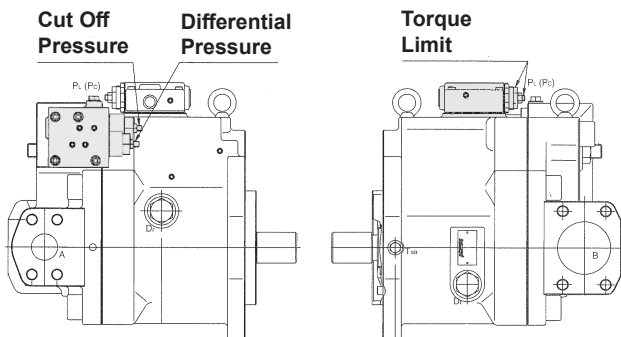

Figure 19 - Hydraulic Pump

Proportional Valve Manifold

Proportional Valve Manifold Consists of Restriction Pressure Gauge, Main Pressure Valve, Restriction Valve and Anti Plug Valve.

System Proportional Valve The MAIN SYSTEM PRESSURE Min-Max pot #2 (see Figure 31 Pg. 22) located in the panel provides a control signal which varies the pressure output from the system proportional valve. When the pot is set at Min, the main system pressure will be at its minimum (approximately 150 to 500 psi). When the pot is set at Max, the main system pressure will be at its maximum (approximately 3000 - 3100 psi).

Main System Pressure Limits (approximate)

Minimum pressure: 150 to 500 psi

Maximum pressure: 3100 psi

Restriction Proportional Valve The Restriction Min-Max pot #3 (see Figure 31 Pg. 22) located in the panel provides a control signal which varies the pressure output from the Restriction Proportional Valve. When the pot is set at Min, the pressure in the restriction rail system will be at its minimum of approximately 75 psi. When the pot is set at Max, the pressure in the restriction rail will be equal to system pressure. The restriction pressure will never exceed main system pressure.

Restriction Pressure Limits (approximate)

Minimum pressure: 75 psi

Maximum pressure: Main System Pressure

Anti Plug Valve The Anti Plug Valve is used to relieve pressure to the restriction rail cylinders, allowing the rails to temporarily open enough to let the plunger fully extend (see Auto Anti Plug Pg. 20).

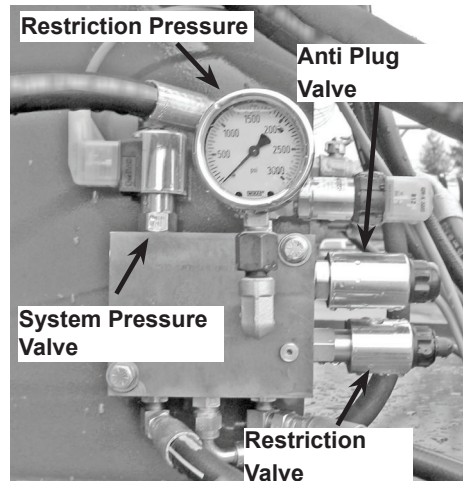

Figure 20 - Proportional Valve Manifold

Control Box

The Control Box is used to control the WE-4. There are controls on the front panel as well as on the inside of the box.

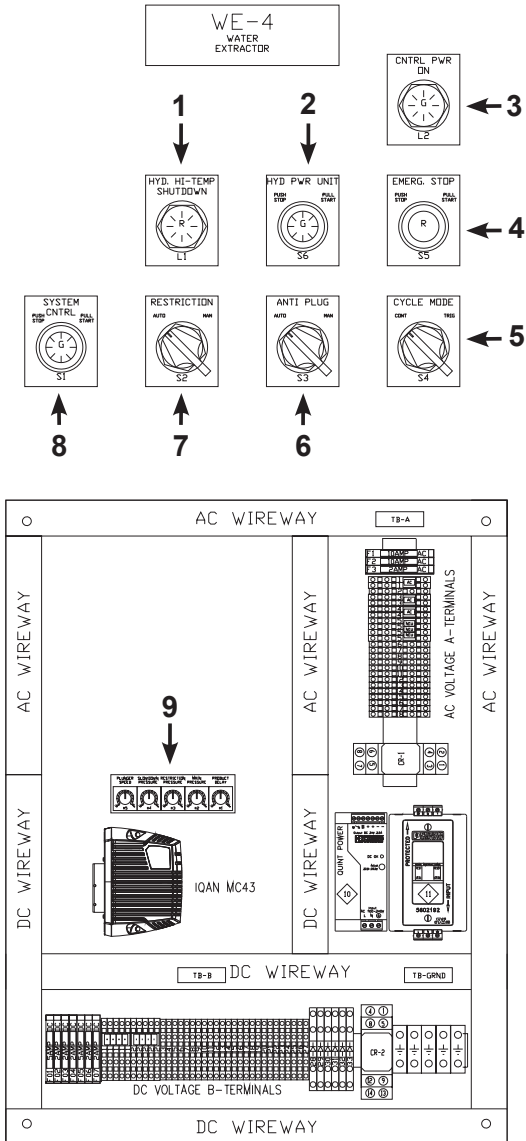

Figure 21 - Control Box

1. HYD HI-TEMP SHUTDOWN (Hydraulic High Temperature Shutdown) Indicator Light (L-1) illuminates when the high temperature switch activates (180° F) and the machine shuts down (see Dual Oil Temperature Switches Pg. 15).

2. HYD. PWR UNIT (Hydraulic Power Unit) Button (S-6) START and STOP the Hydraulic Power Unit electric motor. Make sure there is oil in the reservoir, suction valve in open position and pump is primed (Pg. 13) before turning on the motor.

3. CNTRL PWR (Control Power) Indicator light (L-2) illuminates when the system is on. CNTRL PWR Light and SYSTEM CNTRL light (L-1) need to be on for the plunger to cycle.

4. EMERG STOP (Emergency Stop) Switch (S-5) Shuts down all power to the control panel when in STOP mode. EMERG. STOP button needs to be pulled in the START position to start the WE-4.

5. CYCLE MODE Switch (S-4)

- In CONT with the SYSTEM CNTRL switch in START the plunger will continuously cycle with the option of delaying plunger retract using the Potentiometer Pot #1 (see Potentiometer Adjustments Pg. 22). The In-feed chute level detector is ignored.
- In TRIG, the machine will cycle the plunger when the level detector (PROX 1) on the in-feed chute is triggered (see “Level Detector Adjustments” on page 23)

6. ANTI-PLUG Switch (S-3) AUTO raises restriction rail. MANUAL Anti-Plug valve opens and restriction pressure is zero (0) allowing restriction rail to gradually drop. Use MANUAL mode when unplugging the chamber (see Unplugging Chamber Pg. 24).

7. RESTRICTION PRESSURE Switch (S-2) AUTO is the normal operating setting for the switch. MANUAL setting is only used to either set the system operating and restriction pressures or to allow for manual actuation of the plunger (via the directional valve) at system pressure when the System Control Switch is set to “STOP”.

8. SYSTEM CNTRL (System Control) Switch (S-1) START loads the pump to pressure set by Pot 2 (MAIN SYSTEM PRESSURE). Plunger starts to cycle. STOP main system pressure will go to minimum (150 to 500 psi). Restriction pressure will not exceed main system pressure. Plunger stops and can be controlled manually using the directional valve (see Pg.16).

9. POTENTIOMETER Located inside the control box (see Potentiometer Adjustments Pg. 22). Adjustments for:

- pot #1 PRODUCT DELAY.
- pot #2 MAIN SYSTEM PRESSURE.
- pot #3 RESTRICTION PRESSURE.
- pot #4 SLOW DOWN PRESSURE.
- pot #5 SLOW DOWN PLUNGER SPEED.

Restriction System

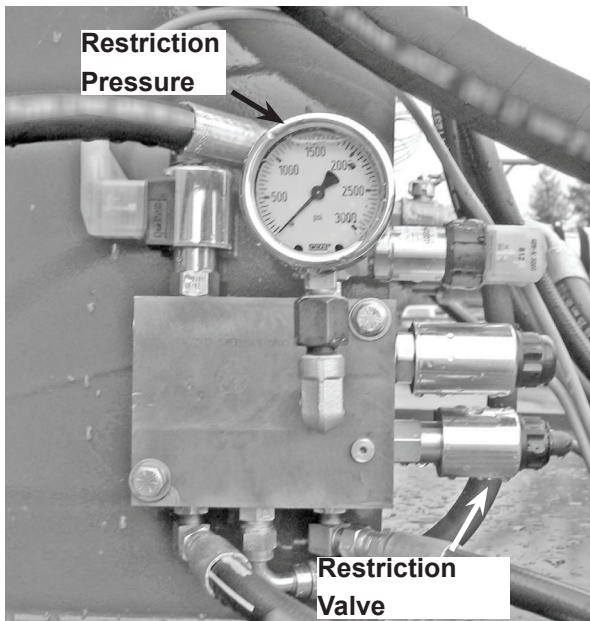

Figure 22 - Restriction System Solenoid Valve

The pressure in the restriction system is set using the Restriction Pressure pot (see potentiometer on page 22) connected to the valve controller. This pot will vary the restriction pressure from approximately 75 psi to 100% of Main Pressure. Turning the pot to Min. will decrease the restriction rail cylinder pressure. Turning the pot to its Max setting will increase the restriction rail system pressure to 100% of the main system pressure. The valve controller will then limit the pressure across the proportional valves (SV-3).

The restriction rail (see Figure 23), provides a variable restriction (modulation) on the passage of product to the discharge. This restriction regulates the force required from the plunger to push the product toward the discharge. It is the compressing action of the plunger that forces the water from the product. The water is evacuated through drain holes in the frame.

The restriction rail is located at the bottom of the discharge chute. The automatic restriction rail control system controls two hydraulic cylinders that operate the restriction rail. The restriction system proportional valve (see Figure 22) controls the force applied by the restriction rail to the product (dewatering pressure), and is adjusted to obtain the desired water content of the discharged product.

The force requirement depends on the products characteristics. The “freeness” and frictional characteristics should be taken into account when adjusting the restriction system proportional valve setting.

Note: Moving the control box RESTRICTION Switch (S-2) from “AUTO” to “MAN” allows the automatic restriction control system feature to be bypassed. In Manual mode, the Restriction Rail cylinder pressure is zero (0) and the Restriction Rail will fully open (lower) (see Figure 23).

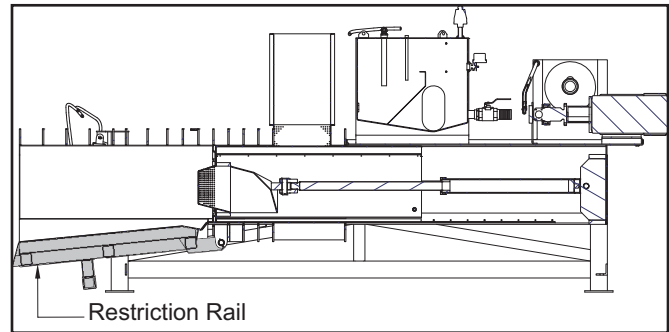

Figure 23 - Restriction Rail Lowered

The poppet valve, mounted next to the hydraulic tank, allows for immediate lowering of restriction rails.

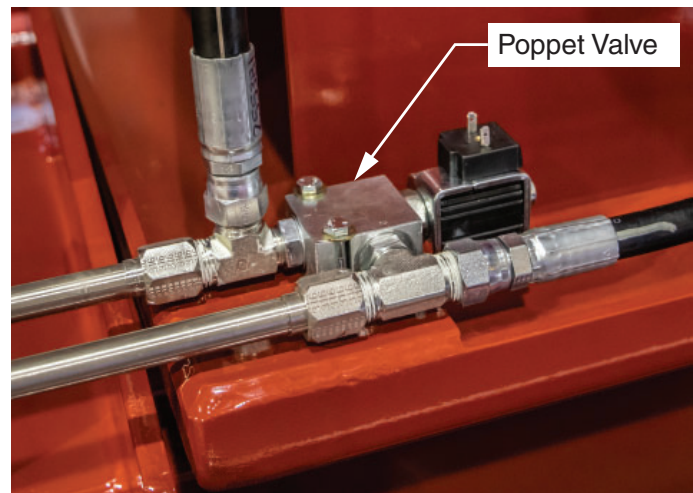

Figure 24 - Poppet Valve

Starting the WE-4



Do not start the equipment until you are certain everyone is clear of the machine and all safety shields.

Follow the following steps when starting your WE-4 Water Extractor. Always make sure SYSTEM CNTRL switch is in STOP position before starting the WE-4. The pump pressure will not exceed approximately 150 to 500 psi, adding longevity to the hydraulic system.

1. Please read entire WE-4 operators manual before start-up.
2. Make sure reservoir is filled with oil, oil float level switch shipping bracket has been removed, suction valves are locked in the open position and the pump is primed (see Pg. 13).
3. Hydraulic oil temperature must be over 40 °F (5 °C) before starting the motor, and over 80 °F (27 °C) before operating the plunger.
4. Freeman recommends setting the potentiometers to the following settings after installation, the first time the water extractor is started:

PRODUCT DELAY	MIN
MAIN SYSTEM PRESSURE	MIN
RESTRICTION PRESSURE	50%
SLOW DOWN PRESSURE.....	MAX
SLOW DOWN PLUNGER SPEED	MAX
5. Push SYSTEM CNTRL switch to STOP (system pressure approximately 150 to 500 psi for idle start).
6. Pull EMERG. STOP switch to START position.
7. Turn RESTRICTION switch to AUTO.
8. Turn ANTI-PLUG switch to AUTO.
9. Turn CYCLE MODE switch to TRIG.
10. Pull HYD. PWR UNIT switch to START.
11. Wait at least 2 seconds, to reduce load on electric motor.
12. Pull SYSTEM CNTRL switch to START (system pressure will equal MAIN SYSTEM PRESSURE pot #3, see Pg. 22).

13. Load material into the feed chute. The plunger will retract according to Product Delay pot #1 when the level detector has sensed product for more than 1 second (see Level Detector Adjustments Pg. 23 and Potentiometer Adjustments on Pg. 22).

Turning off the WE-4

1. Push the SYSTEM CNTRL switch to STOP.
2. Push the HYD. PWR UNIT switch to STOP.

Emergency shut down

1. Push the EMERG STOP switch (see Figure 21 - Pg. 17). This stops the plunger and turns off all power to the water extractor.



The EMERGENCY STOP switch has no load locks, the Water Extractor will coast to a stop.

Automatic and Manual Operation

Automatic Operation

On the control box, place;

1. SYSTEM CNTRL switch to START.
2. RESTRICTION switch to AUTO.
3. CYCLE MODE switch to TRIG (Activates Level Detector) or CONT (Using Potentiometer settings).
4. ANTI PLUG switch to AUTO.

Manual Operation

Place the control box;

1. SYSTEM CNTRL switch to STOP.
2. RESTRICTION switch in MAN.
3. Operate lever on directional valve to operate plunger (see Figure 18 - Pg. 16).

Note: System should be restarted using the SYSTEM CNTRL switch (S-1) to reset system after any manual operation. RESTRICTION switch back to AUTO.

Operation

Auto Anti Plug

When the ANTI PLUG switch is set to AUTO, the anti-plugging function is controlled by the IQAN Module. The Anti-Plug function provides for automatic clearing of a jammed plug when the restriction pressure is too high. This is a timed function that differs based on whether or not the plunger goes into Slowdown Mode (see “Adjustments” on page 22).

1. When the plunger begins to extend, an internal timer begins counting.
- 2A. If the plunger does not go into Slowdown Mode, Auto Anti Plug system starts if the plunger has not fully extended within 8 seconds.
- 2B. If the plunger does go into Slowdown Mode, the internal timer is re-set and begins counting again. Auto Anti Plug system starts if the plunger has not fully extended within 6 seconds of Slowdown Mode being activated.
3. When Auto Anti Plug system starts, the command signal to the Restriction System Proportional Valve is ramped down to approximately 75 psi. The pressure in the restriction system will then begin to bleed down and allow the plunger to force the restriction rails open and move the plug forward.
4. The Restriction System returns to the operating pressure when the plunger reaches full extension (home position).

Plugging The Chamber

Forming a plug in the chamber is the first step and important part of dewatering your product. The application that you are feeding into the machine will be pushed out the discharge end if there isn't a plug formed first. Each application (vegetable waste, paper pulp, etc.) may act differently when trying to form a plug. Sometimes using loose hay is the only way to start a plug. Keep an eye on the volume of product feeding into the In-feed chute while forming the first plug, the machine may overflow.

1. Adjust RESTRICTION PRESSURE Pot #3 to approximately 700 psi (see Figure 32 - Pg. 22). It may be necessary to adjust this pressure up or down to successfully build a plug.
2. Follow **Starting the WE-4** procedures 1 - 11 (Pg. 19)
3. Start feeding material into in feed chute. The chamber should start forming a plug after 7 or 8 plunger strokes. Observe the discharge area where the restriction rail should be in its up most position restricting large volumes of product from exiting the machine.

4. The plug is formed. It may be necessary to adjust RESTRICTION PRESSURE Pot #3 up or down to help keep dewatering consistent once the initial startup plug has been pushed out the discharge end.

If a plug couldn't be formed following steps 1 through 4, try using loose hay or call Freeman service department.

Operation Sequence

CYCLE MODE Switch: TRIG

1. **START-UP SYSTEM CNTRL** switch in START extends the plunger. AUTO PLUG switch in AUTO raises the restriction rail. Product falling through the in-feed chute falls onto the plunger top surface (see Figure 25).

2. **MATERIAL REACHES LEVEL DETECTOR** The level detector (see Level Detector Adjustments - Pg. 23) will send a signal to the IQAN Module program when PROX 1 has been activated by product being sensed for more than 1 second (see Figure 26). The plunger will retract according to PRODUCT DELAY pot #1 (see Potentiometer Adjustments Pg. 22 for adjustments). When the plunger activates PROX 4, the plunger speed is reduced.

3. **PRODUCT FALLS INTO CHAMBER** Plunger retracted and the product falls into the chamber. PROX 4, PROX 3 and PROX 2 activated (see Figure 27 Pg. 21).

4. **PLUNGER EXTENDS** The plunger extends according to the settings of SLOW DOWN PLUNGER SPEED pot #5 and SLOW DOWN PRESSURE pot #4 (see Potentiometer Adjustments Pg. 22 for adjustments).

5. **AUTO ANTI PLUG** starts if the plunger isn't fully extended in a preset amount of time. (see ANTI PLUG page 24). The chamber is most likely plugged if this occurs (see UNPLUGGING CHAMBER Pg. 24). When the plunger passes PROX 3, the restriction rail pressure returns to pot #3 (Restriction Pressure) setting.

6. **PLUNGER STOPS** The plunger stops at full extension (home position), product piling on plunger. PROX 4, PROX 3 and PROX 2 are deactivated (see Figure 28- Pg. 21).

7. **DEWATERING STARTS** Good dewatering starts when product has formed a plug in the chamber with the restriction rail up and the plunger pushing product forward.

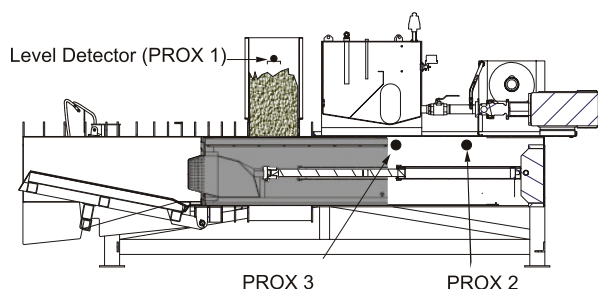

Figure 25 - Product Piling On Top Of Plunger. Plunger In Home Position (fully extended).

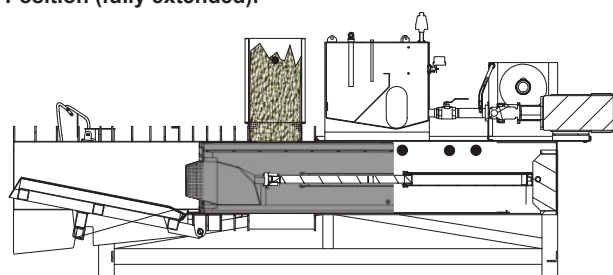

Figure 26 - Product Reaches Level Detector

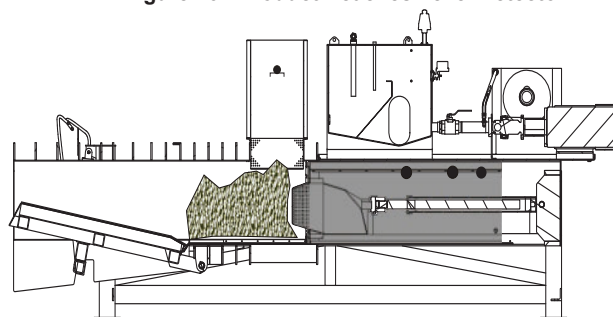

Figure 27 - Plunger Retracts, Product Falls Into Chamber

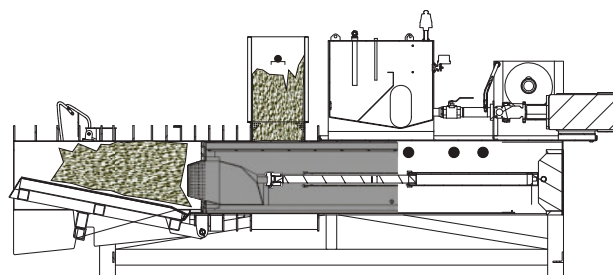

Figure 28 - Plunger Extends, Product Falling On Top Of Plunger

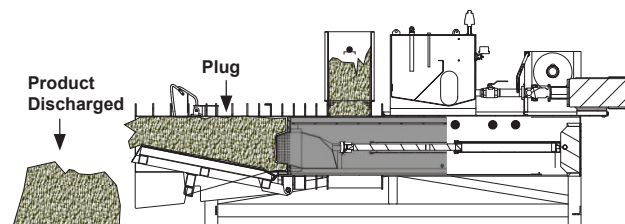

Figure 29 - Plug Formed

NOTE: Any time the system is stopped with the **EMERG STOP** or the **SYSTEM CNTRL Switch**, when re-started the plunger will return to home position (see Figure 25 - Pg. 21).

CYCLE MODE Switch: CONT

1. **START-UP** At start-up the plunger is extended and restriction rail is raised. **SYSTEM CNTRL** switch in **START** extends the plunger. **AUTO PLUG** switch in **AUTO** raises the restriction rail. Product falling through the chute falls onto the plunger top surface.

2. **PLUNGER RETRACTS** The plunger retracts according to **PRODUCT DELAY** pot #1 (see Potentiometer Adjustments Pg. 22 for adjustments). When the plunger activates **PROX 4**, the plunger speed is reduced.

3. **PRODUCT FALLS INTO CHAMBER** The plunger retracts and the product falls into the chamber. The plunger is fully retracted. **PROX 4**, **PROX 3** and **PROX 2** are activated (see Figure 27).

4. **PLUNGER EXTENDS** The plunger extends according to the settings of **SLOW DOWN PLUNGER SPEED** pot #5 and **SLOW DOWN PRESSURE** pot #4 (see Potentiometer Adjustments Pg. 22 for adjustments).

5. **AUTO ANTI PLUG** starts if the plunger isn't fully extended in a preset amount of time (see **ANTI PLUG** page 20). The chamber is most likely plugged if this occurs (see **UNPLUGGING CHAMBER** Pg. 24). When the plunger passes **PROX 3**, the restriction rail pressure returns to pot #3 (Restriction Pressure) setting.

5. **PLUNGER STOPS** The plunger stops at full extension (home position), product piling on plunger. **PROX 4**, **PROX 3** and **PROX 2** are deactivated (see Figure 28).

6. **DEWATERING STARTS** Good dewatering starts when product has formed a plug in the chamber with the restriction rail up and the plunger pushing product forward (see Figure 29).

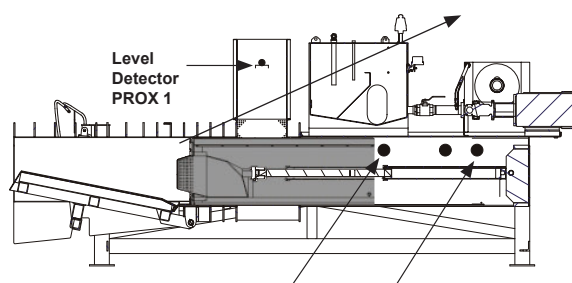

Figure 30 - PROX 4, PROX 3 and PROX 2 Deactivated

Adjustments

Potentiometer Adjustments

The Potentiometer (see Figure 31) located in the control box has 5 adjustments; Product Delay, Main System Pressure, Restriction Pressure, Slow Down Plunger Speed, and Slow Down Pressure.

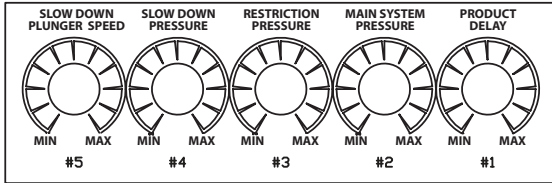

Figure 31 - Potentiometer

PRODUCT DELAY Pot #1. This adjustment increases or decreases the time that the plunger remains in the fully extended or retracted position in CONT. or TRIG. CYCLE MODE. This setting can be adjusted between 0 and 20 seconds.

Turning pot #1 fully CCW will set the delay to 0 seconds and will allow the plunger to cycle continuously. Turning pot #1 CW will increase the time delay up to a maximum of 20 seconds.

MAIN SYSTEM PRESSURE Pot #2 This adjustment varies the Main System Pressure between approximately 500 and 3100 psi. Pressure can be read on the main system pressure gauge (see Figure 18 - Pg. 16).

RESTRICTION PRESSURE Pot #3. This adjustment varies the pressure to the restriction rail cylinders from approximately 75 psi to 100% of the Main System Pressure. Pressure can be read on the restriction pressure gauge (see Figure 22 - Pg. 18). Pressure won't exceed main system pressure.

SLOW DOWN PRESSURE Pot #4. This adjustment sets the pressure at which the plunger goes into slow extend mode. When the pressure in the plunger cylinder exceeds this setting, the plunger will enter slow extend mode, reducing the plunger's extend speed to the SLOW DOWN PLUNGER SPEED setting. This setting can be adjusted from 0 - 100% of the MAIN SYSTEM PRESSURE setting.

SLOW DOWN PLUNGER SPEED Pot #5. This setting is only activated when the plunger cylinder exceeds the SLOW DOWN PRESSURE (pot #4) setting. This adjustment sets the speed with which the plunger extends and compresses the product by varying the flow of hydraulic fluid to the plunger cylinder on the compression stroke. The actual speed depends on the MAIN SYSTEM PRESSURE pot setting and the SLOW DOWN PLUNGER SPEED pot setting. The retract speed is not adjustable.

PRESSURE AND TIME DELAY				
APPROXIMATE VALUES				
	Pot #1	Pot #2	Pot #3	Pot #4
	Product Delay	Main System Pressure	Restriction Pressure	Slowdown Pressure
MIN	0 sec	500 psi	75 psi	0 psi
A	6 - 8 sec	1000 - 1200 psi	25% Main Pressure	25% Main Pressure
B	11 - 13 sec	1700 - 1900 psi	50% Main Pressure	50% Main Pressure
C	15 - 17 sec	2300 - 2500 psi	75% Main Pressure	75% Main Pressure
MAX	20 sec	3100 psi	100% Main Pressure	100% Main Pressure

Figure 32 - Pot, Pressure and Delay. (Values are Approximate)

Level Detector Adjustments

The Level Detector that is located on the side of the in-feed chute (see Figure 33) is active only when CYCLE MODE switch is in TRIG position. The level detector will detect product that sits in front of it for more than 1 second. The level detector will send a signal to the DVC-10 program and the plunger will move according to pot #1 (PRODUCT DELAY) setting (see Potentiometer - Pg. 22).

Freeman recommends adjusting Product Delay pot #1 to MIN for no delay on initial startup. Once the product is detected, the plunger will retract with no delay.

CAUTION

Always turn off system control and lockout the electrical supply to the machine before inspecting, adjusting or servicing the machine.

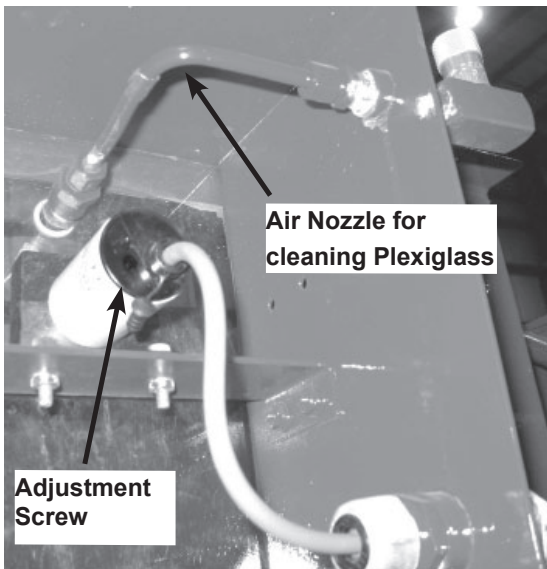

Figure 33 - Level Detector (PROX 1) / Air Nozzle

Air Nozzle For cleaning the Plexiglas in front of the Level Detector. Connect to a compressed air source (supplied by others) with 50 - 100 PSI and approximately 5 CFM.

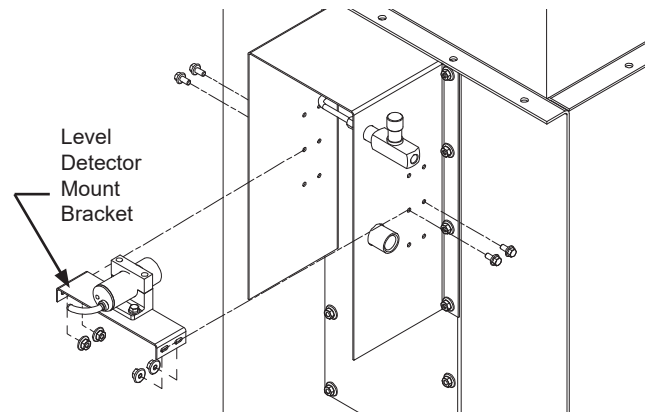

Figure 34 - Level Detector

Level Detector Vertical Position There are three (3) vertical positions the level detector can be adjusted to (see Figure 34). Remove mounting hardware and adjust to the preferred level. Maintain 1/16" clearance between the sensor and the window. Tighten hardware.

Adjust Level Detector Sensitivity The cover plug at the back of the level detector covers the sensitivity adjustment (Figure 33). Remove the cover plug. The plug provides a seal against dirt and moisture.

Note: The level detector sensitivity adjustment screw has no stop. The resistance change of this potentiometer occurs over approximately 16 turns.

Rotating the sensitivity adjustment clockwise increases the detecting distance. Turn the exposed sensitivity adjustment clockwise (+ direction on the detector marking) until the detector switch is turned on (detector light on). Note the position of the screwdriver slot.

Rotating the sensitivity adjustment counterclockwise decreases the detecting distance. Turn the exposed sensitivity adjustment counterclockwise (- direction arrow on the detector marking), noting the number of turns, until the detector switch is turned off (detector light off). Note the number of turns difference between the on and off position.

Now check the sensitivity range of the detector by holding something (piece of cardboard) in front of it. Start out at 3" away from the sensor inside the in-feed chute and slowly move closer to it while watching for the level detectors red light to shine. The plunger will retract once the red light has been on for more than 1 second.

Replace Cover Plug Replace the rubber plug at the back of the level detector. The plug provides a seal against dirt and moisture.

Adjustments / Maintenance

Water Throttling Valve

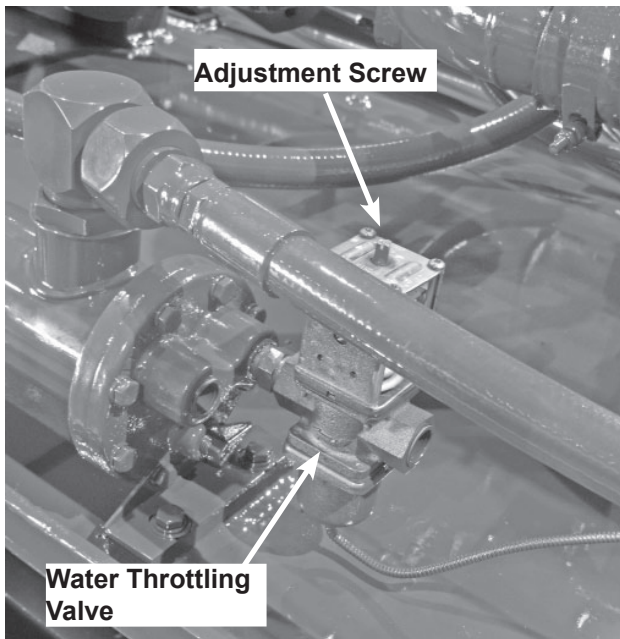

Figure 35 - Throttling Valve

Adjustment: Turn the adjusting screw clockwise to DECREASE opening temperature; turn counterclockwise to INCREASE opening temperature. Valve is fully open 36°F above opening point.

Factory Settings

Plunger retraction delay: Not pre-set

Maximum main system pressure: approximately 3100 PSI

Minimum main system pressure: approximately 150 to 500 PSI

Maximum restriction pressure: approximately 3100 PSI (will not exceed Maximum System Pressure)

Minimum restriction pressure: approximately 75 PSI (see Auto Anti Plug Pg. 21).

Water Throttling Valve: Set to OPEN at 130° F

Temperature Switch: Set to SHUT DOWN system at 180° F.

Maintenance

Unplugging The Chamber

Chamber plugging should never occur unless foreign material gets into the chamber and causes the chamber to plug up.

Anti-plug system operation The control box anti-plug switch energizes the anti-plug solenoid valve (SV-4). The restriction system then reduces the pressure to the restriction rail cylinders to approximately 75 psi, permitting the plunger to more easily discharge the product.

Unplugging steps There are two ways to unplug the chamber:

1. ANTI-PLUG switch in MAN. with Potentiometer Pot #1 set to MIN., SYSTEM CNTRL switch in START. and CYCLE MODE switch in CONT. Feed product to the machine while the plunger cycles to push the plug out the discharge end.
2. HAND REMOVAL Move the Anti-Plug switch to MANUAL to fully open the restriction rail. Turn off water extractor. Use high pressure water or hand tools to manually remove the plugging material.



CAUTION

Always turn off system control and lockout the electrical supply to the machine before inspecting, adjusting or servicing the machine.



CAUTION

An adjustment of the plunger system relief valve to over 3,100 psi will cause pump damage.



WARNING

Pressure greater than 3,100 psi creates a hazard to personnel and can damage the hydraulic system.

Minimum restriction pressure: approximately 75 PSI (0 psi when ANTI PLUG switch is in MAN, see Auto Anti Plug Pg. 21).

Safety Precautions

If maintenance or repairs are to be performed on machine, the following precautions should be observed.

Shut down the system and lock out the hydraulic pump motor and the cooling fan motor at the disconnect switch.

On some machinery, cylinders hold heavy loads. Opening the hydraulic lines with the load raised may permit the load to fall. Hydraulic lines can inadvertently be opened by disconnecting a hose, pipe, or by removing a high pressure filter bowl to change the element. On such machinery, the load should be lowered to rest position before disturbing the hydraulic circuit.

Maintenance Precautions

Think clean!!! The worst enemy of a hydraulic system is contamination. As long as your system is intact, it is nearly impossible for dirt to get into the oil. Dirt gets into the oil when you provide an opening. It can enter through holes left uncovered when you remove some component such as a valve, breather or cap.

If you adhere the following procedure, you will not let dirt into the system.

Clean and wash down the entire area that is going to be worked on. Before removing any component or disconnecting any line, be sure you have the right caps, plugs and cover plates to close the openings that will be exposed.

Thorough cleaning of pipe and hoses before installing or reconnecting is essential. Whenever a pipe or hose is disconnected, or a system component is removed, the system may have to be flushed. For flushing instructions see Pg. 26.

When field repairs on the components are made, flushing the components is necessary. See Pg. 26 for Flushing instructions.

Disassembly of components will void any warranty considerations. Components must be shipped to Allied Systems Co. fully assembled.

Once you have replaced hoses or components, air and contaminants have a chance to enter the system. You must purge the pump for at least 10 minutes to get air out of the system. You may run your pressure up to 3000 once all air is out of the system.

Sight Gauge

An oil level gauge is installed on the reservoir. It will indicate oil level and approximate oil temperature.

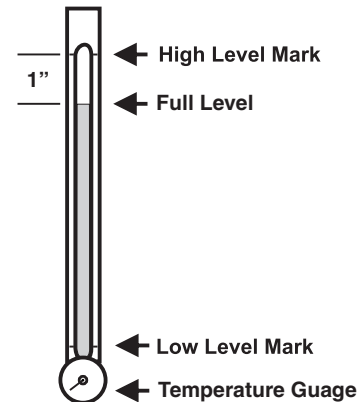

Figure 36 - Oil level sight gauge

Reservoir Oil Level

Oil Level Float switch is installed to detect the oil level. Motor starter shuts off when oil level is 1" below the low level mark. The reservoir is full when the Oil level is 2" to 3" below the High Level Mark with cylinders extended (see Figure 36).

Oil Temperature A dual set point temperature switch is installed to detect oil temperature in the system. If the oil reaches the temperature set on the high circuit adjustment, the switch will automatically shut down the system and turn on an indicator light. The lower setting controls operation of the fan motor and the oil cooler (if so equipped).



WARNING

Avoid high-pressure fluids. Escaping fluid under pressure can penetrate the skin, causing serious injury. Keep hands and body away from pinholes and nozzles which eject fluids under high pressure. Use a piece of cardboard to search for leaks.

Maintenance

Pump and Motor Coupler

The coupling alignment must be within 0.003 total indicator reading on the horizontal, vertical, and angular planes. Adjust as necessary.



WARNING

Pressure greater than 3,100 psi creates a hazard to personnel and can damage the hydraulic system.

Procedure To Fill an Empty Reservoir

1. Reference page 14 for hydraulic oil recommendations.
2. Clean the area around the power unit “fill port”.
3. Install a clean filter element in the return line filter.
4. Pump one gallon of oil into a waste container to flush the filter pump and hose. **Do not use this oil.**
5. Remove the cap from the “fill port”.
6. Fill the reservoir. If this is a start-up, see Reservoir Oil Level on Pg. 25.
7. When reservoir is filled to the “full” index mark on the reservoir’s oil level sight gauge, replace cap on fill port.
8. Open the return line shut-off valve.

Procedure to Add Oil to the Reservoir

1. Reference Pg. 14 for hydraulic oil recommendations.
 2. Lockout the pump at the disconnect switch.
 3. Clean the area around the power unit “fill port”.
 4. Pump one gallon of oil into a waste container to flush the filter pump and hose. **Do not use this oil.**
 5. Remove the cap from the “fill port”.
- Fill the reservoir to the “full” index mark on the reservoir’s oil level sight gage.
6. Close the “fill port” valve and disconnect the filler hose. Replace cap on fill port.
 7. Remove lockout from the disconnect switch.

To Change Oil and Clean a Contaminated Reservoir

1. Lockout the pump at the disconnect switch.

2. Completely drain the reservoir, return line filter housing and return lines.

DO NOT attempt to reuse this oil if it does not conform to original manufacturer’s specifications. This oil MUST be filtered and then tested by the original manufacturer.

The oil **must** conform to the original manufacturer’s specification before reusing, if it does not conform to original manufacturers’ specifications, catastrophic failure may occur.

4. Remove the end cover, clean debris out of reservoir and wipe inside completely clean. Install a new gasket and replace cover.
 5. Install a clean element in the return line filter.
- Fill reservoir with new oil (see Figure 11 - Pg. 14).

Flushing

Allied Systems requires a complete system flush after installation, after intrusion into the system or after a catastrophic failure. Actuator flushing is required when prescribed in certain actuator repair procedures and after catastrophic failure. Most systems can be properly flushed by utilizing the power unit system pump (s) to circulate fluid out through the fluid lines and back through the filter into the reservoir.

Verify the proper amount and type of filtered oil is in the reservoir. Verify enough spare filter elements for all filters are on site before beginning the flushing process. Note: Use only the Allied Systems Co. specified brands and types of filter media.

Avoid flushing through any valves or actuators. These items are pre flushed by Allied Systems Co. or the manufacturer. Loop the existing field installed hose assemblies around these components using unions, with the exception of the power unit blocking valve. Once flushing has started, it is common to get surges of air from the fluid lines into the reservoir, which may cause the pumps to be noisy as air bubbles are drawn into the pump. If the noise persists for long periods of time, and the fluid is aerated or foamy, stop the flushing process and allow the fluid to settle out overnight. If the noise persists beyond a reasonable period of time, consult the manufacturer.

Turbulent flow is essential to all flushing procedures. To achieve this, the Reynolds number (Re) must exceed 4,000 throughout the system. It is calculated as follows:

$$(Re) = (14,646 \times Q) / (v \times d)$$

Where Q = flow rate in GPM, d = pipe I.D. in inches, v = viscosity of fluid in SSU.

Flush only one leg of the system at a time to insure that the proper flow velocity and Reynold's Number (Re) is achieved in each leg. Cap off the other legs.

If necessary, tie multiple pumps together to achieve proper (Re) in each leg of the circuit.

Turbulent flow may also be achieved by vibrating or flexing the lines. Back off the pilot chokes and allow the blocking valve to suddenly open, causing the accumulator oil to surge through the system, giving a temporarily high Reynolds Number (Re).

The system must be flushed so the oil cleanliness meets Allied Systems ISO cleanliness codes 20/17/14. A starting rule of thumb is to flush for a minimum of one hour per 100 ft. of pipe and hose (total of pressure and return lines). While flushing, strike all welds with a hammer to dislodge any scale created as a result of welding.

Before the system may be started-up, the oil **must** be sampled and tested to meet Allied Systems ISO cleanliness codes 20/17/14. This includes every component in the system, especially servo valves and pumps.

If the oil does not meet the ISO cleanliness codes 20/17/14, it could reduce component life or cause Catastrophic Failure, and system flushing must continue.

After flushing is completed, first verify that the oil cleanliness meets Allied Systems ISO cleanliness codes 20/17/14, then verify that no filters are indicating impending bypass. Also verify a supply of spare filter elements are on hand.

Reconnect hoses to actuators & valve packages. Start the pump motor and check for leaks in the entire system.



WARNING

When the pump is restarted after the flushing procedure has been completed, the actuators may move suddenly.

Be sure the machinery is clear of all objects and people.

Preventative Maintenance

Daily

Check oil level in hydraulic power unit reservoir.

Check oil temperature at temperature gauge. Do not start the motor if the hydraulic oil is below 40 °F (5 °C).

When the hydraulic oil is between 40 °F and 80 °F (5 °C and 27 °C) the motor may be started and used to warm the oil to over 80 °F (27 °C) before putting any load on the machine.

Check heat exchanger for any debris that may be blocking the fins, and use air to blow the debris out.

If the system is operating, the temperature should be between 130 °F and 160 °F (54 °C and 71 °C).

Check for leaks around hydraulic power unit.

Weekly

Perform daily service.

Check entire system for leaks.

Check pressure gauge settings.

Check all visual dirt indicators on all filters (Note: Most indicators work only when under full flow condition).

Monthly

Perform Daily & Weekly service.

Clean up any oil that may be in the drip pan.

Check the electric motor to pump coupling insert for alignment and wear and lubricate.

Every Six (6) Months

Perform Daily, Weekly, and Monthly Service.

Sample the oil for cleanliness, viscosity and additives. Oil must meet Allied Systems ISO cleanliness Codes 20/17/14. Change oil accordingly.

If oil is not being tested every six (6) months, then change the oil yearly.

Check for lubrication of the electric motor.

Troubleshooting

Pump

Symptom	Probable Cause	Remedy	Reference
Excessive pump noise	1. Pump/motor coupling misalignment.	Re-align pump & motor accurately. Align to within .003" total indicator reading. Note: Couplings should not be forced tight against each other. Leave a small amount of end play.	
	2. Oil level low.	Fill reservoir so that surface of oil is 2 to 3" below the full mark with cylinders extended.	See Reservoir Oil Level on Pg. 25
	3. Air leak in suction line, air leak in case drain line, or air leak around shaft packing.	Apply packing grease on joints & around shaft while listening for change in sound of operation. Tighten or replace.	
	4. Direction of pump rotation not correct.	A licensed electrician should check the Input Phase.	See Electrical Connection on Pg. 12
	5. Air bound pump.	Air is locked in pumping chamber & has no way to escape. Stop pressure line or install special by-pass line back to tank so that air can pass out of the pump. An air bleed valve need is indicated.	
	6. Restricted flow through suction piping.	Check suction piping & fittings to make sure full size is used throughout. Make sure suction line is not plugged with rags or other foreign material.	
	7. Pump case drain does not terminate below oil level.	Extend slip line piping so that it terminates below the oil surface when oil is at its lowest during any part of one machine cycle.	
	8. Pressure ring is worn.	Replace. This condition caused by hot, thin, dirty oil or no oil at all. An air bound condition will also contribute to the worn pressure ring.	
	9. Restricted filter or strainer.	Clean filter or strainer.	See Hydraulic Power Unit on Pg. 14
	10. Worn or broken parts.	Replace.	
	11. Reservoir air vent plugged.	Air must be allowed to circulate in the reservoir. Clean and /or replace breather.	See Hydraulic Power Unit on Pg. 14

Pump Continued

Symptom	Probable Cause	Remedy	Reference
Bearing failure	1. Chips or other foreign matter in bearings (contamination).	Make sure clean oil is used. Essential for efficient operation & long life of bearings.	
	2. Coupling misalignment.	Re-align pump & motor.	
Pump not delivering oil	1. Wrong direction of pump rotation.	Observe arrow on pump case of name-plate. Direction of rotation must correspond.	See Electrical Connection on Pg. 12
	2. Oil level low in reservoir.	Fill reservoir so that surface of oil is 2 to 3" below the full mark with cylinders extended.	See Reservoir Oil Level on Pg. 25
	3. Air leak in suction line.	Apply good pipe compound non-soluble in oil & tighten joints.	
	4. Suction filter or plugged line.	Filters must be cleaned of lint or dirt soon after first start of unit. Periodic checks should be made as a preventive maintenance precaution.	
	5. Bleed-off in other portion of circuit.	Check for open center valves or other controls connected to tank.	
	6. Oil viscosity too high for proper priming.	Thinner oil should be used per recommendations for given temperatures & service.	
	7. Sheared key at rotor or coupling	Check and replace.	
	8. Pump cover too loose.	Tighten bolts on pump cover.	
Pump not delivering pressure	1. Pump pressure not set high enough	Contact Allied Systems Co. Service Department.	
	2. Oil by-passing to reservoir.	Inspect circuit pressure progressively. Watch for open center valves or other valves open to reservoir.	
	3. Defective pressure gauge or gauge line is shut off. Dirt may plug gauge orifice.	Install good pressure gauge in a line open to pump pressure.	

Troubleshooting

Pump Continued

Symptom	Probable Cause	Remedy	Reference
System excessively hot	1. Pump operates at higher pressures than required	Contact Allied Systems Co. Service Department.	
	2. High ambient temperature.	Relocate power unit or baffle against heat source.	
	3. Oil in reservoir low.	Raise oil level to recommended point.	See Reservoir Oil Level on Pg. 25
	4. Internal System leakage excessive.	Check progressively through the system for losses.	
Leakage at oil seal	1. Seal installed incorrectly.	Correct installation.	See Maintenance, Pg. 24 - Pg. 27
	2. Pressure in pump case.	Observe case drain line for restriction. Check drain line circuitry for excessive back pressure arrangement.	
	3. Poor coupling alignment.	Re-align pump & motor shafts. Align to within .003" total indicator reading.	
	4. Seals damaged during installation. Damaged or scratched shaft seal.	Contact Allied Systems Co. Service Department..	
	5. Abrasives on pump shaft.	Protect shaft from abrasive dust & foreign material.	
Bearing failure	1. Abuse during coupling installation to pump	Most pumps are not designed to handle end thrusts against the drive shaft. Eliminate excessive force when installing coupling. Couplings should be a slip fit onto the pump shaft.	See Hydraulic Power Unit on Pg. 14
	2. Overhung load.	Many pumps are not designed to handle any overhung load or side thrust on the drive shaft. Contact Allied Systems Co. Service Department.	
	3. Incorrect fluid	See manufacture's oil recommendations.	
	4. Excessive or shock load	Contact Allied Systems Co. Service Department.	

Filter

Symptom	Probable Cause	Remedy	Reference
Dirty Oil	1. Plugged Cartridge.	Replace Cartridge.	
	2. Partial bypass continuous.	Correct filter size and oil viscosity.	
	3. Improper micrometer rating.	Check particle size and switch to proper size rating.	
	4. Improper changes.	Correct maintenance procedure or add bypass indicator.	

Troubleshooting

Gauges

Symptom	Probable Cause	Remedy	Reference
Incorrect indication	1. Gauge defective	Check zero pressure & remedy or replace broken tube, broken movement, tube spring, broken needle, pegged needle or gauge pinion gear.	
	2. Check accuracy	Check gauge against calibration standard.	
Poor gauge life	1. Gauge subject to mechanical shock.	Isolate shock by switching to glycerin filled gauge.	
	2. Bourdon tube fatigue	Use gauge isolator to remove continuous pressure on tube.	
	3. Pegged needles	Add pressure flow snubber to restrict needle movement in addition to glycerin (or fluid filled gauge).	
Broken housing	1. Too much pressure	Remove downstream restriction or change to corresponding higher pressure or flow rated filter.	
	2. Too much mechanical shock.	Add shock absorbing material.	
Broken Lens	1. Some degreasers will scratch or "fog" up lens	Replace gauge.	

Machine Function

Symptom	Probable Cause	Remedy	Reference
Adjustments don't seem to work	Not enough time for adjustments to be noticed.	Wait for a minimum of 10 plunger strokes before beginning to judge the effect of the adjustment.	
Plugging	Plunger stalls and motor overload device is tripped.	Reduce restriction pressure.	
Jerky plunger stroke	Air in oil.	The air is most likely between the reservoir and the pump. Replace reservoir filter and make sure fittings are tight between reservoir and pump.	
	Worn or defective plunger piston seals.	Replace piston seals.	
	Intermittent solenoid valve action.	Loose electrical connection. Bad solenoid. Check electrical connection. Replace solenoid.	
	Defective pump.	Replace or have factory service the pump.	
Slow plunger stroke	SLOW DOWN PLUNGER SPEED Pot #5	SLOW DOWN PLUNGER SPEED pot #5 can be set low enough to not allow the plunger to move. Turn pot #5 CW until the plunger reaches the desired speed.	
	Air in oil.	The air is most likely between the reservoir and the pump. Replace reservoir filter and make sure fittings are tight between reservoir and pump.	
	A nonstandard size pump.	Only use a pump recommended from Allied Systems.	
	Worn or defective plunger piston seals.	Replace piston seals.	
	A restriction in the hydraulic system.	Replace filter in reservoir.	



To find a dealer in your area,
Call: 503-625-2560,
Fax: 503-625-7269, or
Visit our website: <http://www.alliedsystems.com>

Allied Systems
COMPANY
PB000WE4OPS66 06/2022
Printed in USA