



Two-tie baling done right.

Smaller, lighter, reliably uniform bales, easily adapted in size and density to suit your operation.

Best in the field.

Our unique design enables the Freeman baler to form the best bale in the business

The Freeman two-tie balers are designed for higher capacity by increasing the power each plunger stroke delivers. The 420 lb flywheel, turning at 600 RPM, drives two 210 lb bull gears, which in turn power the 300 lb plunger at 84 strokes per minute. By using the kinetic energy from the heavy-duty flywheel, bull gears and plunger, these balers can bale up to 20 tons of straw and up to 25 tons of alfalfa per hour.

By designing the baler to use this stored energy during the power stroke of the plunger, the resultant power surges normally experienced when baling in heavy windrows are greatly reduced. This feature minimizes wear on the tractor's drawbar while reducing fuel consumption by smoothing out the power requirements based on the plunger cycle.

2-Tie Baler Models				
	270	275	280	285
Knotter :	Conventional	Tailless	Conventional	Tailless
Tension Control :	1 - Ram Hydraulic (Standard) 3 - Ram Hydraulic (Optional)		3 Hydraulic Cylinders	
Power Options :	Driveline (PTO) Hydro (Hydraulic)		Hydro (Hydraulic)	
Chamber Sizes :	14"x18" 16"x18"			
Chamber Wedges :	Optional		Standard	
Automatic Power Lubrication for Knotters :	Standard	N/A	Standard	N/A
E-Z Glide Tension Controls from tractor seat :	Standard		N/A	
In-Cab Monitor :	N/A		Standard	
Adjustable Pickup Lift :	Standard			
Electric Pickup Lift :	Optional		N/A	
12 Compartment Twine Box :	Standard			
Twine Box Dividers :	Optional			
Bale Counter :	Standard			
Bale and Stroke Counter :	Optional		Standard	
Bale Chute (LH or RH Turning) :	Standard			
Bale Scale :	Optional			
Super Sweep Pickup :	Standard			
Hay Saver Wheel :	Optional			
Bale Weight Indicator :	Optional		Standard	

Contact your local dealer* or visit www.alliedsystems.com/freeman for a complete list of standard and optional features.

* Visit <http://www.alliedsystems.com/dealer> or call 503.625.2560 to find the dealer nearest you.

Freeman two-tie balers are powered for high production!



70 or 80 Series

Choose the 70 Series, the most dependable baler ever made, or the 80 Series for user-friendly convenience.

Hydraulic PTO



Driveline PTO



Power Options

Hydraulic PTO or Driveline PTO.



14" x 18"



16" x 18"

Chamber Sizes

Choose either a 16" x 18" or 14" x 18" chamber.



Conventional or Tailless

Standard conventional knotter, or the optional tailless knotter for clean fields and bales.

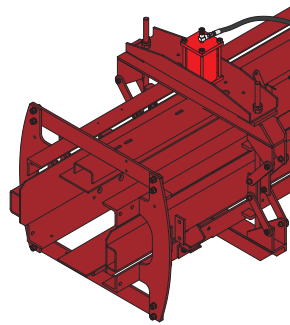

Tension Control - 70 Series

Single ram tension system shown. Or choose optional three ram tension system for increased bale density.

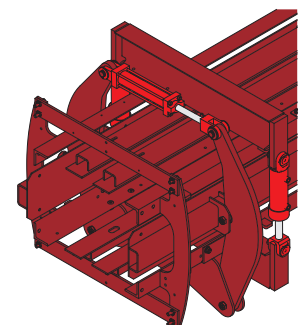

Tension Control - 80 Series

Three cylinder tension system may be opened and closed instantly for easy chamber access.

Freeman two-tie balers are available with Hydro PTO drive or PTO driveline. The 540 rpm hydraulic PTO drive cuts maintenance costs while boosting production. Baler hydraulic oil circulates within its own system, taking the load off your tractor. With the hydraulic PTO, there are no spinning shafts, this helps you bale on sharp turns or straight ahead.



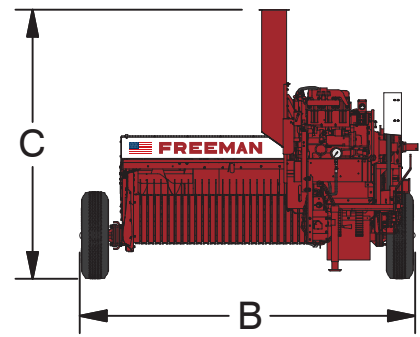
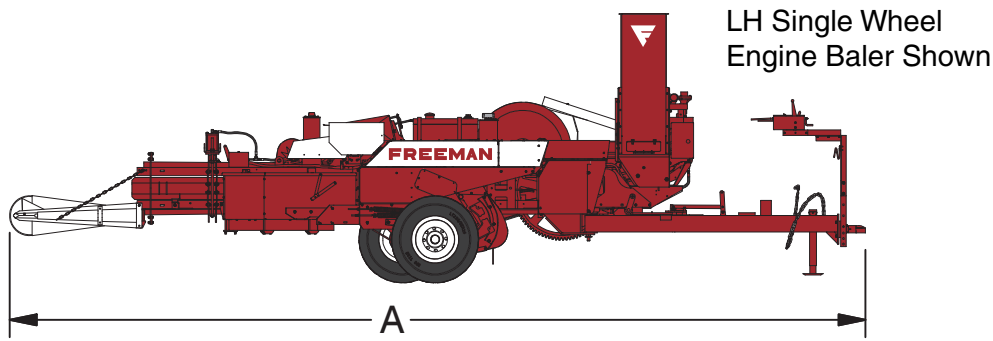

Baler Specifications

Overall Length ("A"):		26' 0" (7924 mm)
Overall Width ("B")	LH Single Wheel:	10' 0" (3048 mm)
	LH Tandem Wheel:	11' 0" (3352 mm)
Overall Height ("C")	Hydro/Driveline:	5' 6" (1676 mm)
Weight	70 Series Hydro:	6,470 lbs (2,934 kg)
	80 Series Hydro:	6,950 lbs (3,152 kg)
Capacity:		25 ton/hour (alfalfa) (22,679 kg)
Strokes/Minute:		84
Bale Size	Cross Section:	16" x 18" (406 x 457 mm) - Standard
		14" x 18" (355 x 457 mm) - Optional
	Length:	18" to 52" (457 - 1321mm)
	Weight Range:	60 to 120 lbs (27 to 54 kg)

Freeman balers will tackle your most demanding haying jobs, profitably. Even the largest windrows are easily baled into rows of neat, even-edged, tightly tied bales. Freeman bales are easier to stack, transport, and feed, and consistently command higher prices from buyers. The Freeman two-tie balers are designed for high capacity and long service life. Bale up to 25 tons an hour with less down time. Our rugged frame construction allows Freeman balers to withstand your demanding production schedules year after year.

Allied Systems is committed to both our customers and our products. Our goal is to provide you with the most rugged, highest capacity, longest lasting equipment available on the market. You will find Freeman products to be the "finest hay handling equipment in the world"

Freeman Factory

21433 SW Oregon Street
Sherwood, OR 97140 USA

Phone: 503.625.2560
800.285.7000
Fax: 503.625.5132
800.231.3273

E-mail: marketing@alliedsystems.com
service@alliedsystems.com
parts@alliedsystems.com
Web: www.alliedsystems.com

Freeman Baler Parts & Service

1662 Zenos Rd
Holtville, CA 92250

Phone: 760.756.3080
Fax: 760.756.3044