

CRA Series Rotators

- ▶ Rotator mounting: Class II
- ▶ Fork bar mounting: Class II
- ▶ Rotation time: 9 seconds
- ▶ Rotation centerline: 12" from bottom of forks
- ▶ Delivered torque: 32,000 in. lb @ 2,000 psi

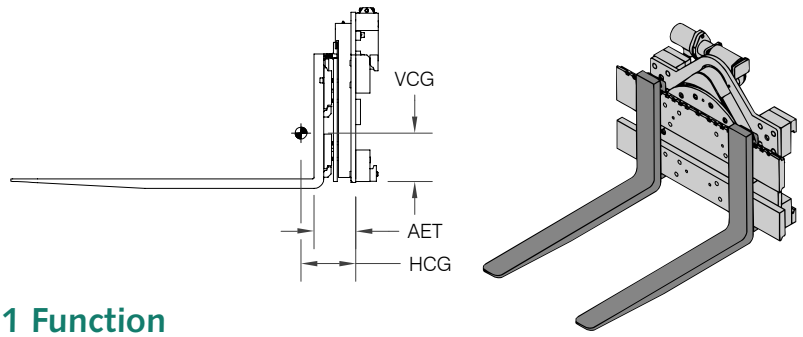

3,500-lb Capacity @ 24" Load Center, 1 Function

Model Number	Fork Bar Width (in) ₂	Fork Size, T x W x L (in)	Mounting Angle (°)	Lost Load			Weight (lb)
				AET (in)	HCG (in)	VCG (in)	
CRA-3532	32	Without	0	7.06	3.6	10.2	580
CRA-3537	37	Forks		7.06	3.7	10.1	600
CRA-3532-FB430	32	1.5 x 4 x 30	0	8.60	5.8	8.7	745
CRA-3532-FB436		1.5 x 4 x 36		8.60	6.5	8.4	765
CRA-3532-FB442		1.5 x 4 x 42		8.60	7.4	8.1	790
CRA-3532-FB448		1.5 x 4 x 48		8.60	8.5	7.8	810
CRA-3537-FB430		1.5 x 4 x 30		8.60	5.8	8.6	765
CRA-3537-FB436	37	1.5 x 4 x 36	0	8.60	6.5	8.4	785
CRA-3537-FB442		1.5 x 4 x 42		8.60	7.4	8.1	805
CRA-3537-FB448		1.5 x 4 x 48		8.60	8.5	7.8	820

₁ If truck's forks are to be on rotators with fork bars only, a third mounting clip must be added to ITA truck forks. Clips are included for ITA Class II.

₂ Maximum fork spacing is less than fork bar width. Consult factory for maximum spacing.



Minimum Truck Carriage Width

Model Number	Minimum Truck Carriage Width (in)
CRA-35	29



Optional Equipment & Information

See Page H-8.



Approximate Net Truck Capacities

Truck Capacity (lb)	Rotator Model	Approx. Net Truck Capacity w/attachment (lb)
3,000	CRA-35	2,245
3,500		2,660
4,000		3,100

Net truck capacities are approximations only for rotator with 32" fork bars and 42" forks installed at 0° on two-stage mast. Actual net truck capacities are available from the lift truck manufacturer only.



Lower Mounting Hooks

Model Number	Mounting Class		Description
	Class	Angle (°)	
AN0	II	0	Bolt-On Std
AQ0			Quick Change



Recommended Hydraulic Supply

Model Number	Flow (gpm)	Max psi
CRA-35	12	2,000

Hydraulic flow less than minimum may reduce operating speed. Higher flow may result in heat build-up, erratic operation and shortened hydraulic system life.

CRA Series Rotators

- ▶ Rotator mounting: Class II
- ▶ Fork bar mounting: Class II
- ▶ Rotation time: 9 seconds
- ▶ Rotation centerline: 12" from bottom of forks
- ▶ Delivered torque: 32,000 in. lb @ 2,000 psi

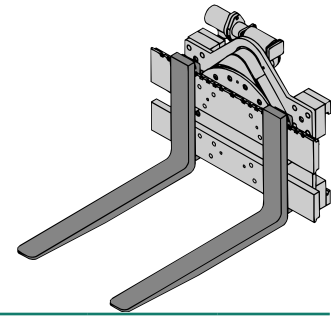
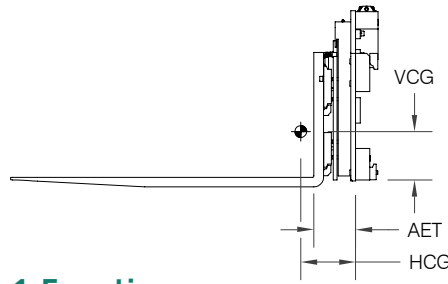

4,500-lb Capacity @ 24" Load Center, 1 Function

Model Number	Fork Bar Width (in) ₂	Fork Size, T x W x L (in)	Mounting Angle (°)	Lost Load AET (in)	HCG (in)	VCG (in)	Weight (lb)
CRA-4532	32			7.06	3.6	10.2	585
CRA-4537	37			7.06	3.7	10.1	605
CRA-4542	42	Without Forks	0	7.06	3.7	10.2	625
CRA-4545	45			7.06	3.8	10.1	640
CRA-4548	48			7.31	4.0	10.0	690
CRA-4532-FB530		1.5 x 5 x 30			6.2	8.5	790
CRA-4532-FB536	32	1.5 x 5 x 36	0	8.60	7.0	8.1	815
CRA-4532-FB542		1.5 x 5 x 42			8.1	7.8	840
CRA-4532-FB548		1.5 x 5 x 48			8.8	7.6	855
CRA-4537-FB530		1.5 x 5 x 30			6.2	8.4	810
CRA-4537-FB536	37	1.5 x 5 x 36	0	8.60	7.0	8.1	835
CRA-4537-FB542		1.5 x 5 x 42			8.0	7.8	860
CRA-4537-FB548		1.5 x 5 x 48			8.8	7.6	875
CRA-4542-FB530		1.5 x 5 x 30			6.2	8.4	830
CRA-4542-FB536	42	1.5 x 5 x 36	0	8.60	7.0	8.1	855
CRA-4542-FB542		1.5 x 5 x 42			8.0	7.8	880
CRA-4542-FB548		1.5 x 5 x 48			8.7	7.6	895
CRA-4545-FB530		1.5 x 5 x 30			6.2	8.5	840
CRA-4545-FB536	45	1.5 x 5 x 36	0	8.60	7.0	8.1	865
CRA-4545-FB542		1.5 x 5 x 42			8.0	7.8	890
CRA-4545-FB548		1.5 x 5 x 48			8.7	7.7	910
CRA-4548-FB530		1.5 x 5 x 30			6.3	8.4	890
CRA-4548-FB536	48	1.5 x 5 x 36	0	8.81	7.1	8.1	915
CRA-4548-FB542		1.5 x 5 x 42			8.0	7.9	940
CRA-4548-FB548		1.5 x 5 x 48			8.7	7.7	960

₁ If truck's forks are to be on rotators with fork bars only, a third mounting clip must be added to ITA truck forks. Clips are included for ITA Class II.

₂ Maximum fork spacing is less than fork bar width. Consult factory for maximum spacing.

! Minimum Truck Carriage Width

Model Number	Minimum Truck Carriage Width (in)
CRA-45	29

! Recommended Hydraulic Supply

Model Number	Flow (gpm)	Max psi
CRA-45	12	2,000

Hydraulic flow less than minimum may reduce operating speed. Higher flow may result in heat build-up, erratic operation and shortened hydraulic system life.

! Approximate Net Truck Capacities

Truck Capacity (lb)	Rotator Model	Approx. Net Truck Capacity w/attachment (lb)
3,000	CRA-45	2,210
3,500		2,650
4,000		3,085
4,500		3,515
5,000		3,950
5,500		4,500

Net truck capacities are approximations only for rotator with 32" fork bars and 42" forks installed at 0° on two-stage mast. Actual net truck capacities are available from the lift truck manufacturer only.

CRA Series Rotators

- ▶ Rotator mounting: Class III
- ▶ Fork bar mounting: Class II
- ▶ Rotation time: 11 seconds
- ▶ Rotation centerline: 14.5" from bottom of forks
- ▶ Delivered torque: 40,000 in. lb @ 2,000 psi
- ▶ High torque option available

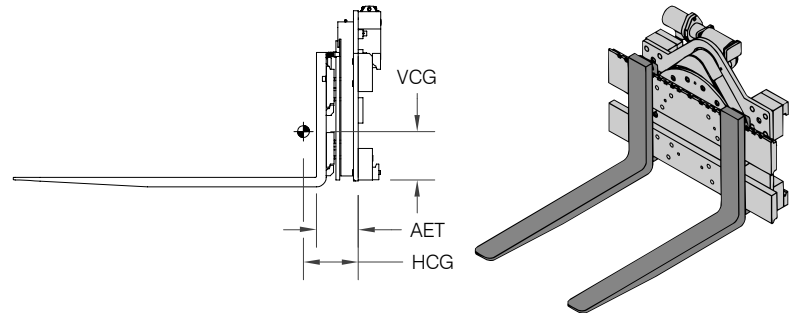

5,500-lb Capacity @ 24" Load Center, 1 Function

Model Number	Fork Bar Width (in) ₂	Fork Size, T x W x L (in)	Mounting Angle (°)	Lost Load			Weight (lb)
				AET (in)	HCG (in)	VCG (in)	
CRA-5537	37			7.5	4.1		696
CRA-5542	42	Without Forks	0	7.5	4.2	12.0	717
CRA-5545	45			7.5	4.4		730
CRA-5548	48			7.8	4.6		776
CRA-5537-FC536		1.75 x 5 x 36			6.8	10.8	1,017
CRA-5537-FC542	37	1.75 x 5 x 42	0	9.3	7.7	10.2	1,047
CRA-5537-FC548		1.75 x 5 x 48			8.7	9.6	1,077
CRA-5537-FC554		1.75 x 5 x 54			9.6	9.0	1,107
CRA-5542-FC536		1.75 x 5 x 36			6.8	10.8	1,038
CRA-5542-FC542	42	1.75 x 5 x 42	0	9.3	7.7	10.2	1,068
CRA-5542-FC548		1.75 x 5 x 48			8.7	9.6	1,098
CRA-5542-FC554		1.75 x 5 x 54			9.6	9.0	1,128
CRA-5545-FC536		1.75 x 5 x 36			6.8	10.8	1,051
CRA-5545-FC542	45	1.75 x 5 x 42	0	9.3	7.7	10.2	1,081
CRA-5545-FC548		1.75 x 5 x 48			8.7	9.6	1,101
CRA-5545-FC554		1.75 x 5 x 54			9.6	9.0	1,131
CRA-5548-FC536		1.75 x 5 x 36			6.9	10.8	1,097
CRA-5548-FC542	48	1.75 x 5 x 42	0	9.6	7.8	10.2	1,127
CRA-5548-FC548		1.75 x 5 x 48			8.8	9.6	1,157
CRA-5548-FC554		1.75 x 5 x 54			9.7	9.0	1,187

₁ If truck's forks are to be on rotators with fork bars only, a third mounting clip must be added to ITA truck forks. Clips are included for ITA Class II.

₂ Maximum fork spacing is less than fork bar width. Consult factory for maximum spacing.

! Minimum Truck Carriage Width

Model Number	Minimum Truck Carriage Width (in)
CRA-55	33

💧 Recommended Hydraulic Supply

Model Number	Flow (gpm)	Max psi
CRA-55	12	2,000

Hydraulic flow less than minimum may reduce operating speed. Higher flow may result in heat build-up, erratic operation and shortened hydraulic system life.

! Approximate Net Truck Capacities

Truck Capacity (lb)	Rotator Model	Approx. Net Truck Capacity w/attachment (lb)
6,000	CRA-55	4,610
7,000		5,500

Net truck capacities are approximations only for rotator with 37" fork bars and 42" forks installed at 0° on two-stage mast. Actual net truck capacities are available from the lift truck manufacturer only.

✕ Optional Equipment & Information

See Page H-8.

CRB Series Rotators

- ▶ Rotator mounting: Class III
- ▶ Fork bar mounting: Class III
- ▶ Rotation time: 11 seconds
- ▶ Rotation centerline: 14.5" from bottom of forks
- ▶ Delivered torque: 40,000 in. lb @ 2,000 psi
- ▶ High torque option available

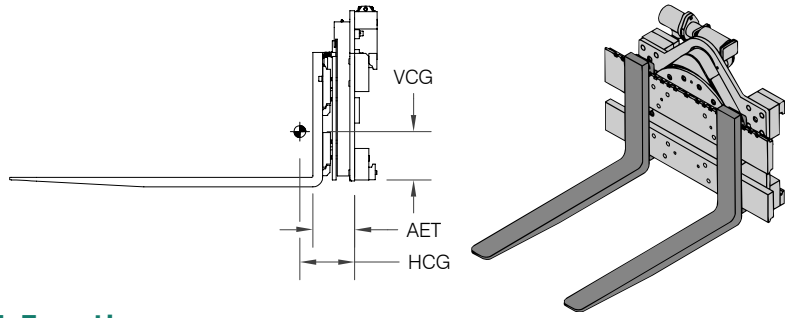

6,500-lb Capacity @ 24" Load Center, 1 Function

Model Number	Fork Bar Width (in) ₂	Fork Size, T x W x L (in)	Mounting Angle (°)	Lost Load AET (in)	HCG (in)	VCG (in)	Weight (lb)
CRB-6537	37			7.5	3.8		773
CRB-6542	42	Without	0	7.5	4.1	12.1	785
CRB-6545	45	Forks		7.5	4.3		792
CRB-6548	48			7.8	4.5		809
CRB-6537-FD536		2 x 5 x 36			6.9	10.8	1,063
CRB-6537-FD542	37	2 x 5 x 42	0	9.5	7.7	10.2	1,097
CRB-6537-FD548		2 x 5 x 48			8.2	9.4	1,131
CRB-6537-FD554		2 x 5 x 54			8.8	9.0	1,165
CRB-6542-FD536		2 x 5 x 36			6.9	10.8	1,091
CRB-6542-FD542	42	2 x 5 x 42	0	9.5	7.6	10.2	1,125
CRB-6542-FD548		2 x 5 x 48			8.2	9.4	1,159
CRB-6542-FD554		2 x 5 x 54			8.8	9.0	1,193
CRB-6545-FD536		2 x 5 x 36			6.9	10.8	1,108
CRB-6545-FD542	45	2 x 5 x 42	0	9.5	7.6	10.2	1,142
CRB-6545-FD548		2 x 5 x 48			8.2	9.4	1,176
CRB-6545-FD554		2 x 5 x 54			8.8	9.0	1,210
CRB-6548-FD536		2 x 5 x 36			7.0	10.8	1,125
CRB-6548-FD542	48	2 x 5 x 42	0	9.5	8.0	10.2	1,159
CRB-6548-FD548		2 x 5 x 48			9.0	9.6	1,193
CRB-6548-FD554		2 x 5 x 54			10.0	9.0	1,227

₁ If truck's forks are to be on rotators with fork bars only, a third mounting clip must be added to ITA truck forks. Clips are included for ITA Class III.

₂ Maximum fork spacing is less than fork bar width. Consult factory for maximum spacing.

! Minimum Truck Carriage Width

Model Number	Minimum Truck Carriage Width (in)
CRB-65	33
CRB-90	39

! Recommended Hydraulic Supply

Model Number	Flow (gpm)	Max psi
CRB-65	12	2,000

Hydraulic flow less than minimum may reduce operating speed. Higher flow may result in heat build-up, erratic operation and shortened hydraulic system life.

! Approximate Net Truck Capacities

Truck Capacity (lb)	Rotator Model	Approx. Net Truck Capacity w/attachment (lb)
6,000	CRB-65	4,550
7,000		5,450
8,000		6,300
9,000		6,500

Net truck capacities are approximations only for rotator with 37" fork bars and 42" forks installed at 0° on two-stage mast. Actual net truck capacities are available from the lift truck manufacturer only.

Optional Equipment & Information

See Page H-8.

CRB Series Rotators

- ▶ Rotator mounting: Class III or IV
- ▶ Fork bar mounting: Class III
- ▶ Rotation time: 13 seconds from bottom of forks
- ▶ Rotation centerline: 14.5"
- ▶ Delivered torque: 50,000 in. lb @ 2,000 psi
- ▶ High torque, dual-drive option available

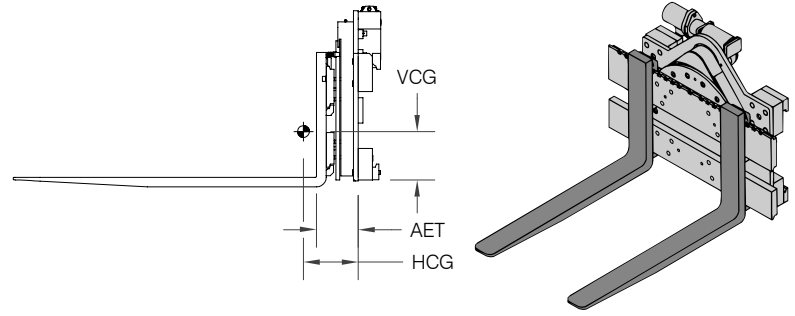

9,000-lb Capacity @ 24" Load Center, 1 Function

Model Number	Fork Bar Width (in) ₂	Fork Size, T x W x L (in)	Mounting Class	Angle (°)	Lost Load AET (in)	HCG (in)	VCG (in)	Weight (lb)
CRB-9042	42	Without Forks	III	0	7.95	4.1	12.9	898
			IV		9.75	4.2	12.9	1,018
CRB-9048	48	Without Forks	III	0	7.95	4.1	12.9	932
			IV		9.75	4.2	12.9	1,052
CRB-9060	60	Without Forks	III	0	7.95	4.5	12.9	1,000
			IV		9.75	4.3	12.9	1,120
CRB-9042-FD642		2 x 6 x 42	III	0	9.95	8.5	9.4	1,310
			IV		11.75	8.6	9.4	1,430
CRB-9042-FD648	42	2 x 6 x 48	III	0	9.95	9.4	9.4	1,351
			IV		11.75	9.5	9.4	1,471
CRB-9042-FD654		2 x 6 x 54	III	0	9.95	10.6	9.3	1,392
			IV		11.75	10.7	9.3	1,512
CRB-9042-FD660		2 x 6 x 60	III	0	9.95	11.9	9.3	1,433
			IV		11.75	12.0	9.3	1,553
CRB-9048-FD642		2 x 6 x 42	III	0	9.95	8.4	9.4	1,344
			IV		11.75	8.5	9.4	1,464
CRB-9048-FD648	48	2 x 6 x 48	III	0	9.95	9.4	9.4	1,385
			IV		11.75	9.5	9.4	1,505
CRB-9048-FD654		2 x 6 x 54	III	0	9.95	10.5	9.3	1,426
			IV		11.75	10.6	9.3	1,546
CRB-9048-FD660		2 x 6 x 60	III	0	9.95	11.9	9.3	1,467
			IV		11.75	12.0	9.3	1,587
CRB-9060-FD642		2 x 6 x 42	III	0	9.95	8.3	9.4	1,412
			IV		11.75	8.4	9.4	1,532
CRB-9060-FD648	60	2 x 6 x 48	III	0	9.95	9.4	9.4	1,453
			IV		11.75	9.5	9.4	1,573
CRB-9060-FD654		2 x 6 x 54	III	0	9.95	10.5	9.3	1,494
			IV		11.75	10.6	9.3	1,614
CRB-9060-FD660		2 x 6 x 60	III	0	9.95	12.0	9.3	1,535
			IV		11.75	12.1	9.3	1,655

¹ If truck's forks are to be on rotators with fork bars only, a third mounting clip must be added to ITA truck forks. Clips are included for ITA Class III.

² Maximum fork spacing is less than fork bar width. Consult factory for maximum spacing.



Recommended Hydraulic Supply

Model Number	Flow (gpm)	Max psi
CRB-90	12	2,000

Hydraulic flow less than minimum may reduce operating speed. Higher flow may result in heat build-up, erratic operation and shortened hydraulic system life.



Approximate Net Truck Capacities

Truck Capacity (lb)	Rotator Model	Approx. Net Truck Capacity w/attachment (lb)
9,000	CRB-90	6,945
10,000		7,790
11,000		8,610
12,000		9,000

CRC Series Rotators

- ▶ Rotator mounting: Class IV
- ▶ Fork bar mounting: Class IV
- ▶ Rotation time: 14 seconds
- ▶ Rotation centerline: 20.5" from bottom of forks
- ▶ Delivered torque: 125,000 in. lb @ 2,000 psi

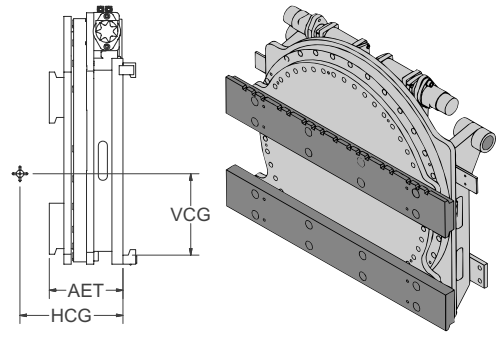

12,500 lb Capacity @ 24" Load Center, 1 Function

Model Number	Fork Bar Width (in) ₂	Fork Size, T x W x L (in)	Mounting Angle (°)	Lost Load AET (in)	HCG (in)	VCG (in)	Weight (lb)
CRC-1249	49	Without Forks	0	9.75	6.0		1,477
CRC-1261	61			9.75	6.1	15.5	1,555
CRC-1273	73			9.75	6.2		1,633
CRC-1249-FF648		2.5 x 6 x 48			9.5	12.1	2,086
CRC-1249-FF660	49	2.5 x 6 x 60	0	12.25	11.9	11.5	2,188
CRC-1249-FF672		2.5 x 6 x 72			13.0	11.0	2,239
CRC-1261-FF648		2.5 x 6 x 48			9.6	12.1	2,164
CRC-1261-FF660	61	2.5 x 6 x 60	0	12.25	11.8	11.5	2,266
CRC-1261-FF672		2.5 x 6 x 72			12.9	11.0	2,317
CRC-1273-FF648		2.5 x 6 x 48			9.4	12.1	2,242
CRC-1273-FF660	73	2.5 x 6 x 60	0	12.25	11.8	11.5	2,344
CRC-1273-FF672		2.5 x 6 x 72			12.9	11.0	2,395

₁ If truck's forks are to be on rotators with fork bars only, a third mounting clip must be added to ITA truck forks. Clips are included for ITA Class IV.

₂ Maximum fork spacing is less than fork bar width. Consult factory for maximum spacing.

! Minimum Truck Carriage Width

Model Number	Minimum Truck Carriage Width (in)
CRC-12	39

! Recommended Hydraulic Supply

Model Number	Flow (gpm)	Max psi
CRC-12	24	2,000

Hydraulic flow less than minimum may reduce operating speed. Higher flow may result in heat build-up, erratic operation and shortened hydraulic system life.

! Approximate Net Truck Capacities

Truck Capacity (lb)	Rotator Model	Approx. Net Truck Capacity w/attachment (lb)
12,000	CRC-12	8,625
13,500		9,895
14,000		10,300
15,000		11,110
15,500		11,500

Net truck capacities are approximations only for rotator with 49" fork bars and 48" forks installed at 0° on two-stage mast. Actual net truck capacities are available from the lift truck manufacturer only.

Optional Equipment & Information

See Page H-8.

CRC Series Rotators

- ▶ Rotator mounting: Class IV
- ▶ Fork bar mounting: Class IV
- ▶ Rotation time: 14 seconds
- ▶ Rotation centerline: 23" from bottom of forks
- ▶ Delivered torque: 110,000 in. lb @ 2,000 psi

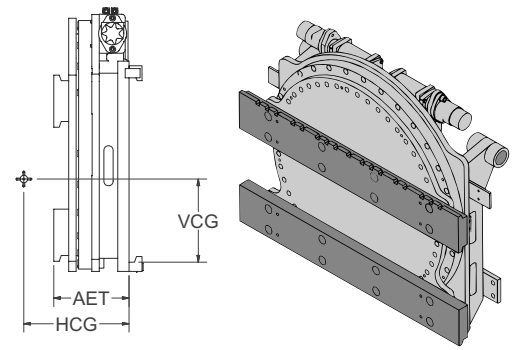

16,000 lb Capacity @ 24" Load Center, 1 Function

Model Number	Fork Bar Width (in) ₂	Fork Size, T x W x L (in)	Mounting Angle (°)	Lost Load			Weight (lb)
				AET (in)	HCG (in)	VCG (in)	
CRC-1649	49			9.75	5.1		1,730
CRC-1661	61	Without Forks	0	9.75	5.3	18.5	1,820
CRC-1673	73			9.75	5.5		1,910

₁ If truck's forks are to be on rotators with fork bars only, a third mounting clip must be added to ITA truck forks. Clips are included for ITA Class IV.

₂ Maximum fork spacing is less than fork bar width. Consult factory for maximum spacing.

CRD Series Rotators

- ▶ Ideal for mining, forging, steel and other heavy industry

20,000- to 46,000-lb Capacities, 1 Function

Model Number	Capacity @ L.C. (lb)	No. of Independent Drive Assemblies
CRD-20NB	20,000 @ 24"	2
CRD-30NB	30,000 @ 48"	3
CRD-40NB	46,000 @ 48"	4

Consult factory for specifications on these models.

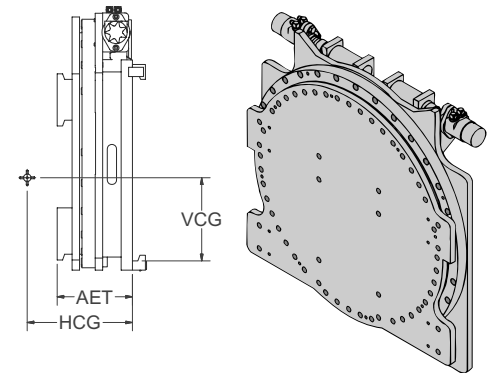

! Minimum Truck Carriage Width

Model Number	Minimum Truck Carriage Width (in)
CRC-16	40
CRD-20 / 30 / 40	Consult Factory

Optional Equipment & Information

See Page H-8.

Recommended Hydraulic Supply

Model Number	Flow (gpm)	Max psi
CRC-16 / CRD-20	24	2,000
CRD-30 / 40	40	2,250

Hydraulic flow less than minimum may reduce operating speed. Higher flow may result in heat build-up, erratic operation and shortened hydraulic system life.

CR Series – Optional Equipment

Optional Features

Options

Fork Modifications: (Sizes not shown)

Full Bottom Taper (per Pair)

Hard Surface Tips (per Pair)

Fork Bar Modifications: (Widths not shown)

Consult
Factory

Fork Mounting Clips:

(When truck forks are to be used on rotators with fork bars only, a third mounting clip must be added to ITA truck forks.)

For ITA Class II, III or IV

Std

Restricted Rotation: 90° – 180° – 270°

Mounting Options: Integral or Pin-Type (see Section J)

Consult
Factory

ITA Dual Mounting: Standard Bolt-On

Class II & III

Class III & IV

Installation Kits

Model Number	Number of Functions
YHJL-6-S-30	1
YHJL-8-S-30	

Includes hoses and fittings to connect a standard attachment to the hose terminal on the lift truck carriage.

Lower Mounting Hooks

Model Number	Class	Mounting		Description	
		Angle (°)			
ANO	II	0		Bolt-On	Std
AQO		0		Quick Change	
BNO	III	0		Bolt-On	Std
BQO		0		Quick Change	
CNO	IV	0		Bolt-On	Std
CQO		0		Quick Change	

Recommended Hydraulic Supply

Model Number	Flow (gpm)	Max psi
CRA-35 through CRC-11	12	2,000
CRC-12 through CRD-20	24	2,000
CRD-30 / 40	Consult Factory	

Hydraulic flow less than minimum may reduce operating speed. Higher flow may result in heat build-up, erratic operation and shortened hydraulic system life.