

**INSTALLATION, MAINTENANCE
AND SERVICE MANUAL
FLN AND FLS**

TABLE OF CONTENTS

SECTION	PAGE	SECTION	PAGE
1	NAME PLATE LOCATION.....	5	MAINTENANCE SCHEDULE.....
2	MODEL NO. DESCRIPTION	6	SERVICE PROCEDURE
	FLN Model Number	6.1	Attachment Removal.....
	FLS Model Number.....	6.2	Cylinder Removal.....
		6.3	Cylinder Installation
3	SAFETY SUMMARY	6.4	Cylinder Disassembly
3.1	General Information	6.5	Cylinder Inspection
3.2	Load Handling	6.6	Cylinder Assembly
3.3	Load Positioning	6.7	Hydraulic Valve Removal
3.4	Hydraulics	6.8	Hydraulic Valve Installation.....
3.5	Operation Controls	6.9	Torque Specifications
4	INSTALLATION PROCEDURE		
4.1	Truck Requirements.....		
4.2	Carriage		
4.3	Hydraulics		
4.4	Attachment Installation		
4.5	Fork Cylinder Anchor		
4.6	Fork Installation.....		
4.7	Hydraulic Connections		

SECTION 1

NAMEPLATE LOCATION

NOTE: WHEN YOU RECEIVE YOUR ATTACHMENT, LOCATE THE LONG REACH NAMEPLATE (UPPER LEFT CORNER ON THE BODY) AND RECORD THE INFORMATION TO THE BLANK NAMEPLATE TAG WITH THE DATE RECEIVED IN THE SPACE PROVIDED ON THE BOTTOM OF THIS PAGE. IF THE NAME PLATE IS MISSING, LOOK FOR THE SERIAL NUMBER STAMPED DIRECTLY INTO THE METAL AT THE ORIGINAL LOCATION AND CONSULT FACTORY.

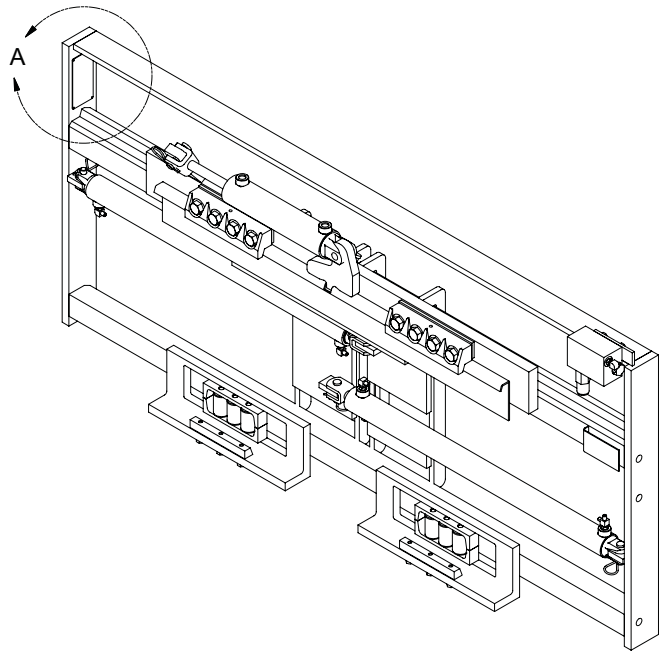

Date Received:

<input type="text"/>	<input type="text"/>	-	<input type="text"/>	<input type="text"/>	-	<input type="text"/>	<input type="text"/>
----------------------	----------------------	---	----------------------	----------------------	---	----------------------	----------------------

		A Division of Allied Systems Company				21433 SW Oregon Street Sherwood OR 97140 USA www.alliedsystems.com		2500005 rF	
		MODEL NO.: <input style="width: 100%;" type="text"/>		SERIAL NO.: <input style="width: 100%;" type="text"/>					
CAPACITY AT LOAD CENTER:		<input style="width: 50%;" type="text"/>	KG @	<input style="width: 50%;" type="text"/>	MM	<input style="width: 50%;" type="text"/>	KG	<input style="width: 50%;" type="text"/>	MM
MASS:		<input style="width: 50%;" type="text"/>	(LBS) @	<input style="width: 50%;" type="text"/>	(IN)	<input style="width: 50%;" type="text"/>	(LBS)	<input style="width: 50%;" type="text"/>	(IN)
MAXIMUM HYDRAULIC PRESSURE:		<input style="width: 50%;" type="text"/>	BAR	<input style="width: 50%;" type="text"/>	L/min	<input style="width: 50%;" type="text"/>	MM	<input style="width: 50%;" type="text"/>	MM
FLOW:		<input style="width: 50%;" type="text"/>	(PSI)	<input style="width: 50%;" type="text"/>	(GPM)	<input style="width: 50%;" type="text"/>	(IN)	<input style="width: 50%;" type="text"/>	(IN)
HCG:		<input style="width: 50%;" type="text"/>	VCG:	<input style="width: 50%;" type="text"/>	LCG:	<input style="width: 50%;" type="text"/>	(IN)	<input style="width: 50%;" type="text"/>	(IN)
DATE:		<input style="width: 100%;" type="text"/>							
		SEE TRUCK NAMEPLATE FOR COMBINED TRUCK & ATTACHMENT CAPACITY							

SECTION 2

MODEL NUMBER DESCRIPTION

Each clamp is identified by a model number and a serial number located on the name plate attached to the unit prior to shipment. Long Reach's model numbers are designed to describe how an attachment is equipped. The guide below illustrates the information that is represented in an 15-digit model number. Always include model and serial number when ordering parts or requesting service information.

FLN Series Model Number:

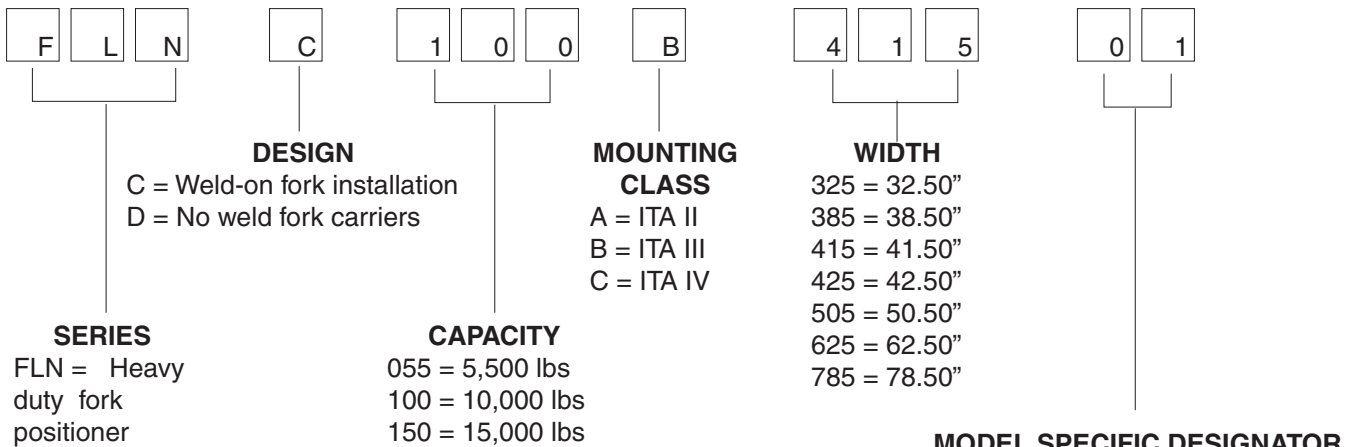

Note:
Weld = Weld cylinder anchor on the back of fork
No- Weld = Supplied fork carrier

FLS Series Model Number:

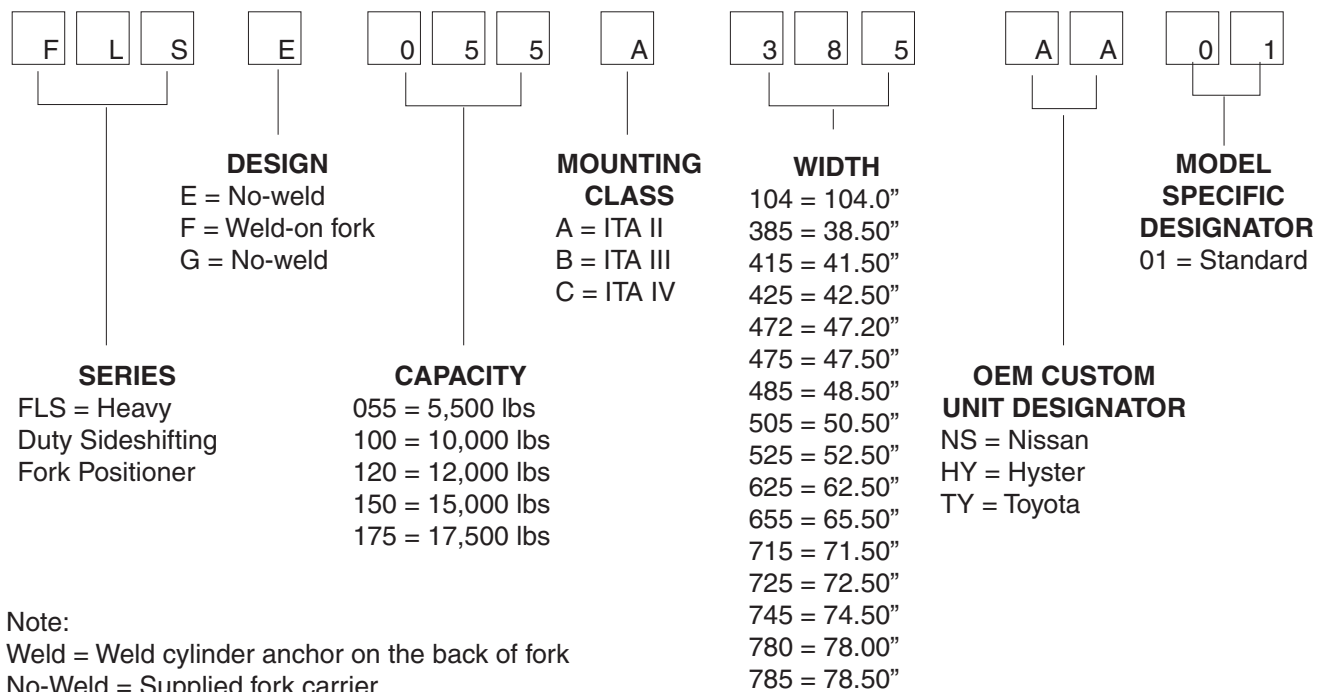

Note:
Weld = Weld cylinder anchor on the back of fork
No-Weld = Supplied fork carrier

SECTION 3 SAFETY SUMMARY

3.1 General Information

Safety is Everyone's Responsibility

Whether you are new on the job or a seasoned veteran, these safety tips may prevent injury to you, to others, or to the materials you are handling. Always be alert, watch out for others, and follow these suggestions:

Attachments Handle Material - Not People.

**SAFETY STARTS WITH COMMON SENSE.
GOOD JUDGEMENT, PROPERLY MAINTAINED
EQUIPMENT, CAREFUL OPERATION, AND
PROPERLY TRAINED OPERATORS.**

1. **Check** your equipment before you operate it.
2. **Check** to make sure the attachment on your truck is the same as on the truck capacity plate.
3. **Check** for hydraulic leaks and cracked hoses or fittings.
4. **Check** the hydraulic oil level in the lift truck hydraulic reservoir.
5. **Check** for physical damage to the attachment. If anything looks wrong, unusual or different, report it before using the attachment.
6. **When** removing / installing dismountable attachments always keep hands and feet free from dangerous positions or pinch points. Never leave a dismounted attachment in a dangerous position.
7. **Check** to make sure that the dismountable attachment is properly secured to the truck carriage before using the lift truck and attachment.
8. **Never** stand on top of material being raised, lowered, or transported. (Figure 3-1)
9. **Never** use the attachment or its load to support a man carrying device.

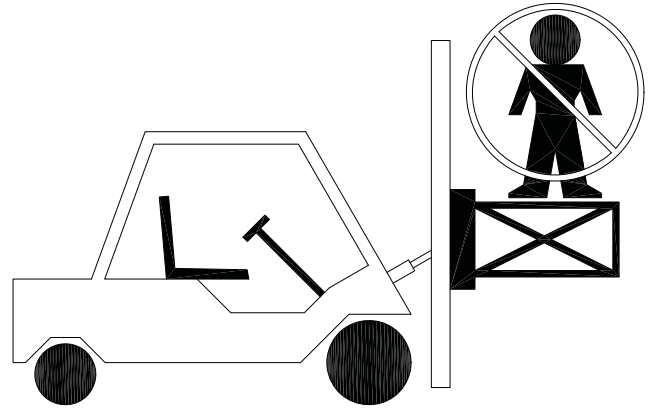

Figure 3-1

10. **Never** position an attachment or load over people. (Figure 3-2)
11. **Never** leave an attachment or load in an elevated position.

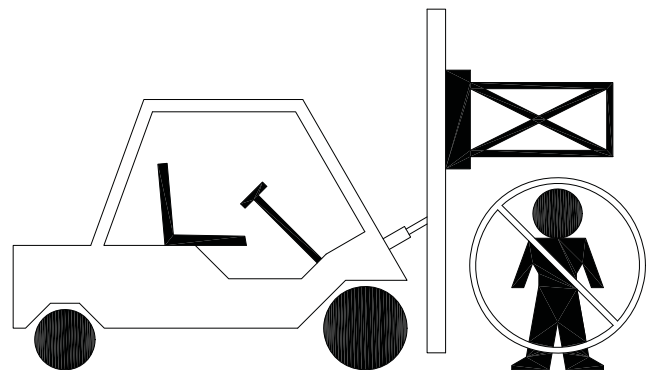

Figure 3-2

12. **Never** reach through the mast of the truck. Keep all parts of the body within the driver's compartment.
13. **Never** leave a lift truck unattended without lowering the load to the floor, setting the brake, and turning the truck off.
14. **Always** operate an attachment from the operator's seat, never while standing next to the lift truck.

15. **Never** stand in front of or beside an attachment that is being operated. Never allow another person to approach an attachment that is being operated. (Figure 3-3)

16. **Do not** allow riders on the truck at any time.

17. **Always** use reverse when carrying a load that impedes full vision.

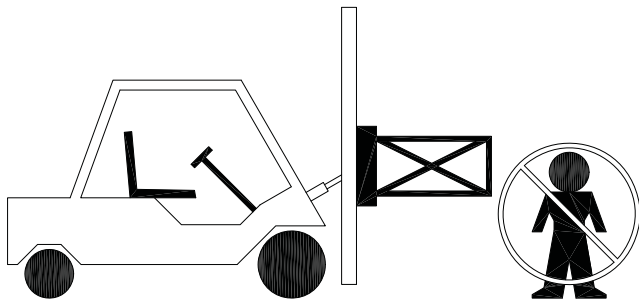

Figure 3-3

18. **Watch** for pedestrians when transporting. Sudden stops can dislodge all or part of a load.

3.2 Load Handling

1. **All** operators must be trained and qualified.

2. **Never** overload the attachment. Refer to the attachment nameplate for the rated capacity of the attachment. Refer to the nameplate of the truck for the net working capacity of the truck and attachment. Observe the lower of the two capacities. The attachment capacity is the structural rating of the attachment and should not be exceeded. Net working capacity is the truck manufacturer's rating of the truck/attachment combination.

3. **Never** use a load to support or move another object. Doing so can easily exceed the holding capacity of the attachment, causing loss of the load.

4. **Never** lift, lower, side shift, pivot, rotate, or tilt loads while traveling. Repositioning loads while traveling affects the stability of the truck and may impede vision or clearances.

5. **Never** speed or race a lift truck. High speed adversely affects the stability and steering of the lift truck.

6. **Do not** use an attachment to open or close boxcar doors. Doing so can severely damage the attachment and cause loss of warranty. Damage to clamp arms may result in product damage.

7. **Do not** carry loose items or unsupported loads on top of a clamped load.

8. **Never** allow anyone under a load or under the carriage.

9. **Never** use chains, cables, or other devices in conjunction with an attachment for load handling.

10. **Never** clamp loads other than what the attachment was designed to handle.

11. **Travel** slowly around corners. Sound horn on blind corners. Be careful of tail swing and overhead clearances. Watch in all directions. Avoid sudden stops.

12. **Do not** exceed the specified maximum operating pressure or flow for the attachment. To do so can severely damage the attachment and cause loss of warranty.

3.3 Load Positioning

1. **Always** operate an attachment from the driver's seat.

2. **Always** lower the attachment if you need to leave the lift truck. Remember a lift truck supporting a load requires your full attention.

3. **Never** use the attachment or its load to support or move other loads or equipment.

4. **Always** carry loads as close to the floor as possible, consistent with the surface being traversed. Scraping or bumping the floor surface with the load or the attachment can severely damage the attachment and cause product damage. The mast should be tilted back.

5. **Always** keep the load positioned as close as possible to the horizontal center of the lift truck.

6. **Always** back down ramps or inclines. Driving forward down a ramp or incline with a clamped load will lessen the stability of the truck. (Figure 3-4)

LONG REACH[®]

7. **Do not** cross dock boards or dock levelers with the attachment or carriage fully lowered. Ramming the front or rear of the attachment against a dock board can cause severe damage.

8. **Always** check loads to be handled. If they are broken, unbalanced, loose, or too heavy, advise a supervisor or properly correct the situation prior to handling.

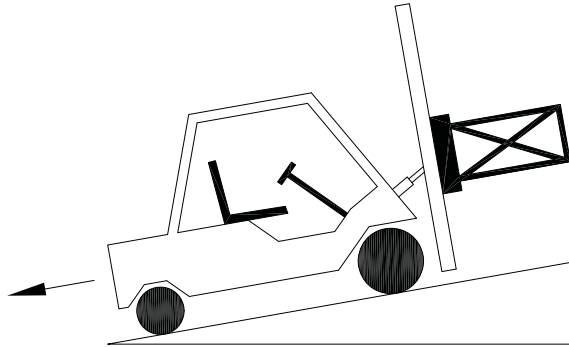

Figure 3-4

9. **Limit** lift truck movement to a minimum when high stacking. Limit sideshift movement to a minimum when high stacking.

10. **Always** be observant when high stacking. Look for poorly stacked loads, overhead obstacles, broken cartons, or damaged products in the stack.

11. **Always** carry cylindrically shaped loads in the vertical position, not the horizontal.

12. **Always** clamp loads with the contact pads, if applicable, not the arm or arm base.

13. **Never** rotate a load that is off center to the centerline of rotation. Severe damage to the rotator could result.

14. **Always** check the attachment for proper fit and engagement of the truck carriage.

3.4 Hydraulics

1. **Be aware** of the hazards of pressurized hydraulics:

2. **Wear** personal protective equipment, such as gloves and safety glasses, whenever servicing or checking a hydraulic system.

3. **Assume** that all hydraulic hoses and components are pressurized. Relieve all hydraulic pressure before disconnecting any hydraulic line.

4. **Never** try to stop or check for a hydraulic leak with any part of your body; use a piece of cardboard to check for hydraulic leaks. Small hydraulic hose leaks are extremely dangerous, and can inject hydraulic oil under the skin, even through gloves. Infection and gangrene are possible when hydraulic oil penetrates the skin. See a doctor immediately to prevent loss of limb or death.



3.5 Operator's Controls

1. For clarity, the direction of arm movement is shown on the control handle. To move the arms in the direction shown, pull the handle towards the operator. To move the arms in the opposite direction, push the handle away from the operator. (Figure 3-5)

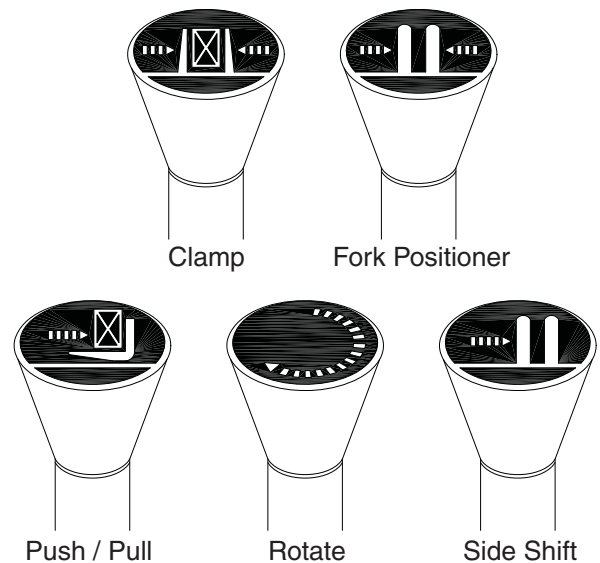

Figure 3-5

NOTE: OSHA OR STATE REGULATIONS MAY REQUIRE THE INSTALLATION OF BACKRESTS. WE SUGGEST THAT YOU CHECK YOUR APPLICATION AGAINST THOSE REQUIREMENTS.

SECTION 4

INSTALLATION PROCEDURE



WARNING

THE CAPACITY OF THE TRUCK AND ATTACHMENT COMBINATION MAY BE LESS THAN THE CAPACITY SHOWN ON THE ATTACHMENT ALONE. CONSULT TRUCK NAMEPLATE!

NOTE: IT IS THE RESPONSIBILITY OF THE DEALER AND / OR THE USER EITHER TO FURNISH AND INSTALL THE REQUIRED VALVING TO MEET THE RECOMMENDED HYDRAULIC PRESSURES AND FLOW OR TO ARRANGE INSTALLATION OF THE REQUIRED VALVING AT THE TRUCK FACTORY OR AT LONG REACH. RECOMMENDED HYDRAULIC SUPPLIES ARE AS FOLLOWS:

	Min.	Max.	PSI
Class II	3.2	4.1	2,200 - 3,000
Class III	2.9	6.4	2,200 - 3,000
Class IV	4.0	12.0	2,200 - 3,000

4.1 Truck Requirements

Long Reach attachments have been designed to operate within specific limits. Operating pressures above the stipulated maximum may cause structural damage to the attachment and may result in loss of warranty. Hydraulic flow less than the recommended rates, or the use of small I.D. hoses may reduce operating speed. Higher flow can result in excessive heat buildup, erratic operation and damage to the truck / attachment hydraulic system.

4.2 Carriage

1. The truck carriage must conform to the American Society of Mechanical Engineers (ASME) dimensions shown in ASME B56.11.4-1992, reaffirmed 2000.

2. Make sure the truck carriage is clean, conforms to ASME recommendations, and that the notched edges are free of burrs.

4.3 Hydraulics

1. The truck hydraulic system must supply to the attachment hydraulic oil that meets the specifications required to operate the attachment properly.

2. When the truck hydraulic system pressures (PSI) exceeds specified maximum, a relief valve is recommended in the attachment auxiliary system of the truck or on the attachment.

3. When the truck hydraulic system flow (gpm) exceeds specified maximum, a flow control valve is recommended to ensure optimal performance.

4. Consult the truck factory and / or Long Reach for guidance.

4.4 Attachment Installation

1. Prior to connecting the truck hydraulic system to the attachment, the system **must** be purged through the filtration system. This will eliminate any contamination that might exist in the auxiliary hydraulic system of the truck.

2. Purging can be accomplished by installing a jumper line and operating each hydraulic function (clamp, rotate and side shift if equipped) in each direction for a minimum of 30 seconds. (Figure 4-1)

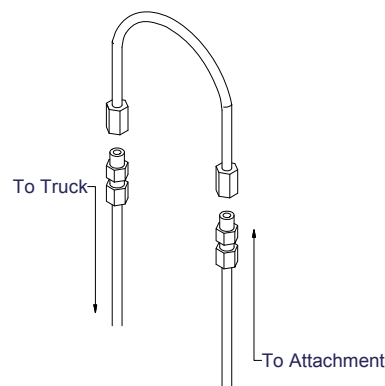

Figure 4-1, Jumper Line

3. Remove the lower bolt-on retainers and, if applicable, make a note of any factory installed shims. Shims are used to space the retainer closer to the truck carriage. If the attachment is equipped with Quick Change Hooks, simply remove the Retaining Pin and the Quick Change Hook (Figure 4-2).

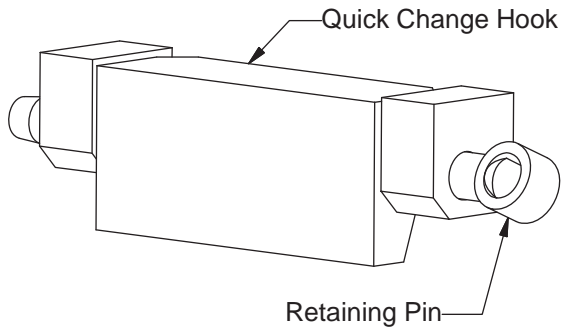

Figure 4-2, Quick Change Hook

4. Center the truck behind the attachment and drive toward the attachment with the mast tilted forward approximately 4 degrees.

5. Line up the locking lug (under the mid plate, if applicable) with the appropriate notch on the truck's carriage. Check that the bronze side shifting wear strips are in the proper place, if applicable.



6. Slowly raise the truck carriage completely to engage the top hooks with the truck carriage. Tilt carriage back until the unit is against the carriage bottom fork bar (0 degrees).

7. Inspect for proper engagement of the locking lug in the corresponding notch of the truck's carriage. Inspect any wear strips, if applicable, to ensure they are properly aligned in the top hooks.

8. To install the lower roller assemblies (side-shift) use a suitable device to move the attachment away from the carriage approximately 2". Place a block between the attachment and the carriage to hold it in position. Install the rollers into the heel plate pockets on the lower right and left hand sides of the attachment. The rollers do not need to face a particular direction. Gently move the bottom of the attachment out to remove the block. Lower the attachment down the face of the carriage. Ensure that the rollers remained in the pockets and are in contact with the carriage.

9. Install the bolt-on lower hooks. Inspect clearance to the carriage on lower hooks. Adjust the lower hooks for a maximum clearance of **3/32"** (see Figure 4-4). On Class II and Class III units, tighten the 3/8" bolts to **33 ft-lbs**. On Class IV units tighten the 1/2" bolts to **77 ft-lbs**. On units using 9/16" UNC bolts, tighten the bolts to **112 ft-lbs**.

10. Weld on the supplemental locking lug that is supplied with the attachment, (two pieces of 1/2 x 1/2 x 2.00 steel included with the attachment) with either E-6011 or E-6013 Welding Rod, or equivalent, on each side of the truck carriage. (Figure 4-3). Locking lugs are not required for side shifting units with midplates.

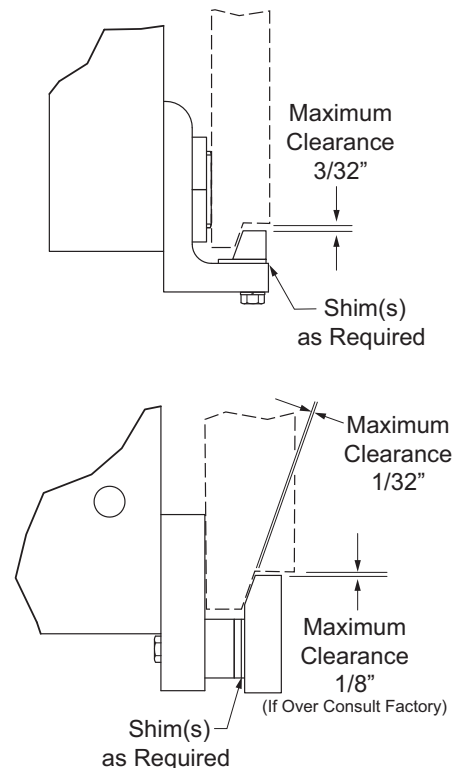

Figure 4-4, Lower Hook Clearance

11. If Quick Hooks are installed, place the retaining pin through the quick change hook.

12. Apply grease to bronze top hooks through fittings and spread on entire slide area of mid plate.

13. Check all fittings, connections and bolts for any interference.

4.5 Fork Cylinder Anchor (Some FLS and FLN Models)

1. Refer to documentation that came with your machine for fork lug location.

2. Make sure cylinder is parallel to carriage weldment.

NOTE: CYLINDER ANCHORS ARE SHIPPED WITH NEW ATTACHMENTS. ALWAYS PROTECT CYLINDER ROD FROM WELD SPATTER, ETC.

Narrow Fork

1. Tighten the included long Allen set screws until they touch the forks. Without further tightening of the set screws, tighten the installation jam nut against the carrier to **41 ft-lbs**.

2. Check the set screws for interference.

3. Apply grease to face of the upper and lower fork bars.

Wide Fork

1. Tighten the included short Allen set screws until they touch the forks. Without further tightening of the set screws, tighten the installation jam nut against the carrier to **41 ft-lbs**.

2. Check the set screws for interference.

3. Apply grease to face of the upper and lower fork bars.

4.6 Fork Installation Instructions



WARNING

OVER-TORQUING THE INSTALLATION HARDWARE CAN RESULT IN A BENT POSITIONER SIDE PLATE AND/OR BROKEN SET SCREW(S).

NOTE: CYLINDER ROD CLEVIS PINS MUST BE REMOVED TO SLIDE THE FORK POSITIONERS INTO ALIGNMENT WITH THE INSTALLATION NOTCHES ON THE FORK BOTTOM BAR.

4.7 Hydraulic Connections

1. Install the lines from the truck's hydraulics to the attachment hydraulics. (Figure 4-6)
2. Inspect installation to ensure hoses are not kinked or pinched between the truck carriage and attachment.
3. Operate the attachment continuously for several minutes to determine that all hydraulic connections are secure with no leaks.
4. With the mast in the vertical position, open the attachment arms fully. After this procedure, check that the truck's hydraulic reservoir oil level is at the recommended level.
5. Before placing the attachment in operation check the following:
 - a. Inspect all hoses and fittings for leaks and routing clearance. Be sure to include clearance of jumper hoses to the mast.
 - b. Check the valve and cylinder for leaks.
 - c. Check cotter pins at each end of the cylinder for security.
6. After completing the installation, operate the attachment without a load for several cycles to remove any air in the hydraulic system. Test the attachment with a load to make sure the attachment operates correctly.

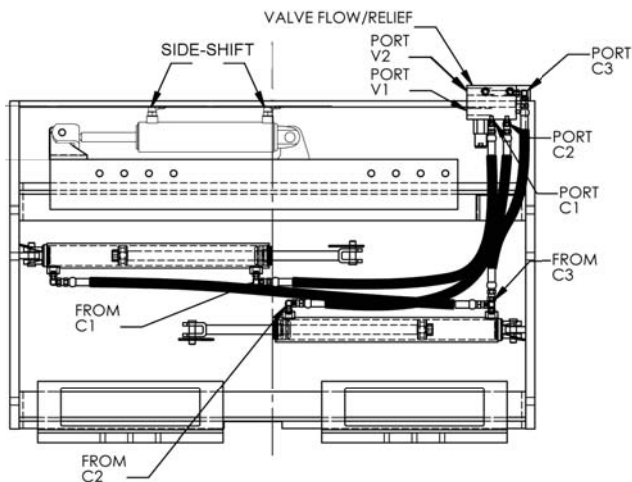
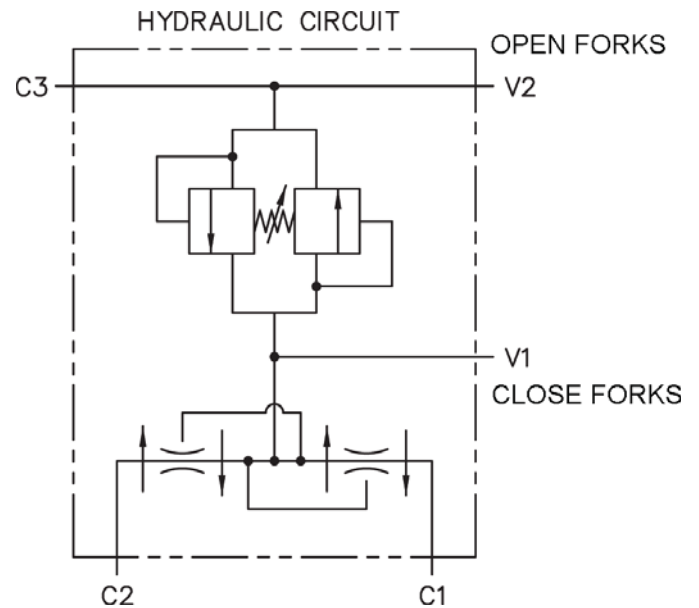

Figure 4-7, Hydraulic Connection

SECTION 6 SERVICE PROCEDURE

6.1 Attachment Removal

1. Position the attachment arms to the width of the unit's body.



WARNING

BEFORE DISCONNECTING ANY HYDRAULIC CONNECTIONS BE SURE TO TURN OFF THE TRUCKS POWER AND ACTIVATE THE TRUCKS HYDRAULIC FUNCTIONS IN BOTH DIRECTIONS TO BLEED OFF THE HYDRAULIC PRESSURE.

2. Disconnect the hydraulic connection for the attachment positioning at the hydraulic valve, ports V1 and V2. (Figure 6-1)

3. Disconnect the side shift connections.

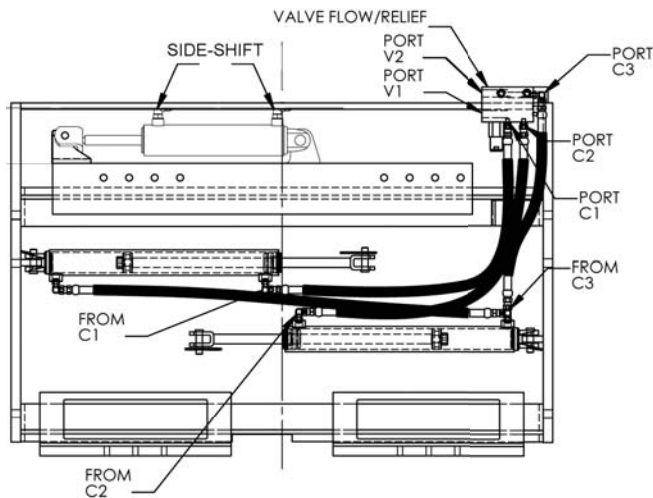

Figure 6-1, Hydraulic Connection

4. Slightly raise the truck carriage to allow the removal of the bottom mounting hooks. If the attachment is equipped with Quick Change Hooks, simply remove retaining pin and pull lower hooks down. (See Figure 6-2)

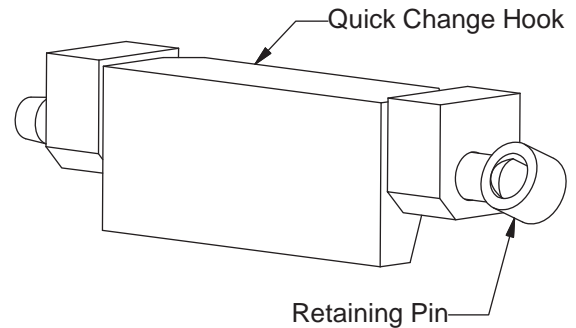

Figure 6-2, Quick Change Hook

5. Position the attachment on the edge of a pallet. Lower the attachment so that the lower carriage bar misses the pallet when lowered. Tilt the mast forward to allow the carriage to disengage from the upper mounting hooks and back away. If lowering onto a floor, blocks of wood can be placed under the body of the attachment to raise the rear.

6. To reinstall, follow the installation procedure in this manual.



WARNING

WHEN HYDRAULIC SERVICING HAS BEEN PERFORMED, BEFORE RETURNING ATTACHMENT TO SERVICE BE SURE TO ACTIVATE THE HYDRAULIC FUNCTIONS SEVERAL TIMES TO BLEED OUT TRAPPED AIR IN THE SYSTEM.

6.2 Cylinder Removal

1. Remove the cylinder rod end cotter pin and clevis pin.

2. Disconnect the hydraulic connections.

3. Remove cotter pin and clevis pin at the base end of the cylinder.

6.3 Cylinder Installation

1. Install the clevis pin and cotter pin into the base end of the cylinder.
2. Attach the hydraulic connections to the cylinder.
3. Extend the cylinder until the rod end hole lines up with the mounting hole. Install the clevis pin and cotter pin into the rod end of the cylinder.
4. Turn on the truck's power and activate the positioning cylinders several times to bleed out trapped air.



WARNING

WHEN HYDRAULIC SERVICE HAS BEEN PERFORMED, BEFORE RETURNING ATTACHMENT TO SERVICE BE SURE TO ACTIVATE THE HYDRAULIC FUNCTIONS SEVERAL TIMES TO BLEED OUT TRAPPED AIR IN THE SYSTEM.

6.4 Cylinder Disassembly

1. Remove the cylinder from the attachment. See removal instructions.
2. Clamp the cylinder lightly at the base end in a soft jawed vise. Use a block or other support under the rod end of the cylinder. (Figure 6-3)
3. Spread and remove the retaining ring from the gland cap.
4. Push gland inward 1 inch and pry out lock ring.

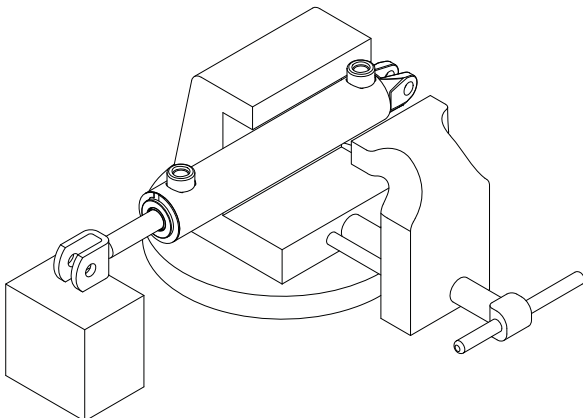

Figure 6-3, Cylinder Vise

5. Remove the rod assembly from the cylinder tube.
6. Clamp the rod assembly in a soft jawed vise on the wrench flats, **not on the rod surface**. If the rod does not have wrench flats use two pieces of wood on both sides of the rod to prevent scaring. (Figure 6-4)

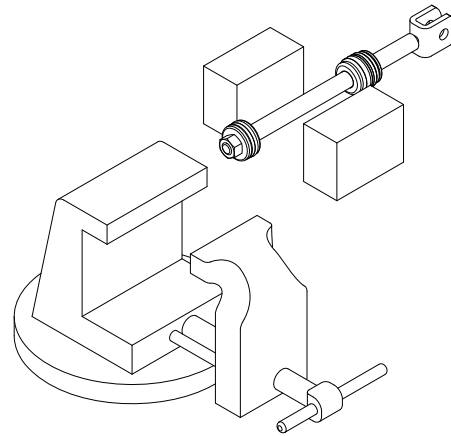

Figure 6-4, Cylinder Shaft

7. Remove the piston retaining nut and remove the piston. (Figure 6-5)

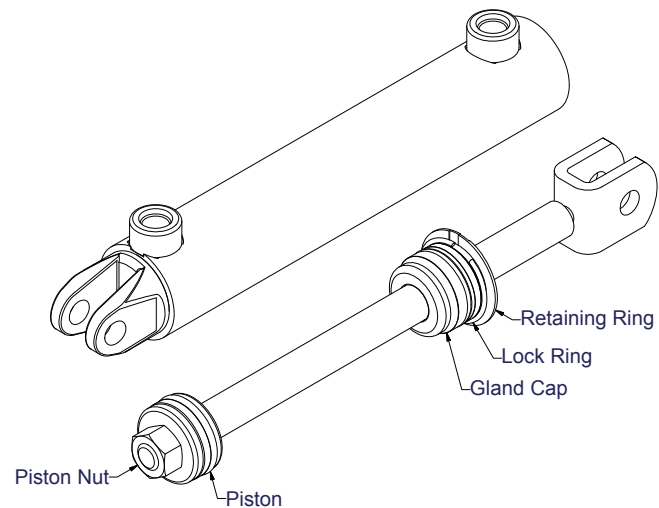

Figure 6-5, Rod Assembly

8. Carefully pry up on the piston seals using a blunt tip screw driver being careful not to scratch the seal grooves. Cut the seals to remove from the piston. (Figure 6-6)

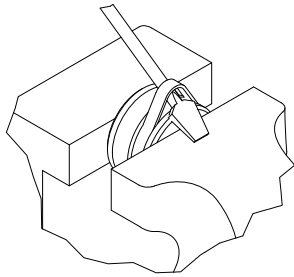

Figure 6-6, Piston Seal

9. Use the same procedure as above to remove the seals from the gland cap.

6.5 Cylinder Inspection

Inspect the cylinder tube bore for:

1. Deep scratches or nicks.
2. Signs of galling or excessive wear.
3. Out-of-roundness or deformities of the barrel.

Inspect the Piston for:

1. Scratches or nicks on seal grooves.
2. Wear on O.D.

Inspect the Cylinder Rod for:

1. Scratches or nicks on the rod surface.
2. Straightness of the rod.
3. Damaged threads.

Inspect the Gland Cap for:

1. Scratches or nicks in seal grooves.
2. Damaged threads or spanner wrench holes.
3. Excessive wear in bore.

Replace any component found to be bad.

6.6 Cylinder Assembly

1. Spray the Piston, Gland Cap, and Seals with WD40 or other similar product to ease slipping of the seals in place.

2. Note the direction of the seal on the piston. Improper installation will result in poor performance. The cupped side or O-Ring side of the seal should be facing the gland cap. (Figure 6-7)

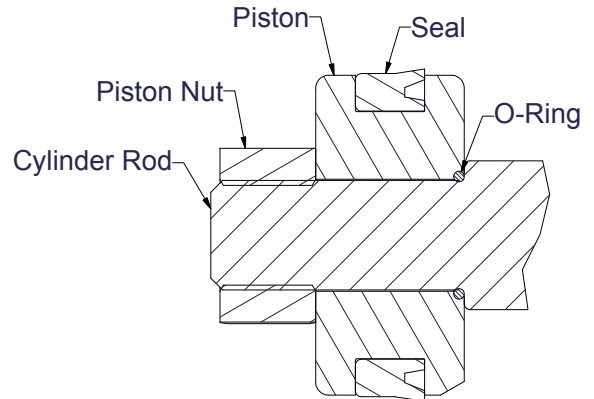

Figure 6-7, Piston Seal

3. Install the seals and wipers in the gland cap. Note the direction of the seals. The cupped side or O-Ring side of the seal should be facing the piston. (Figure 6-8)

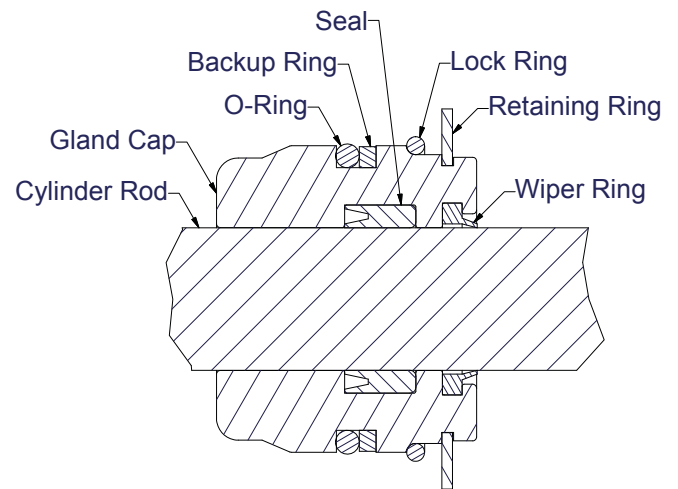

Figure 6-8, Gland Cap Seal

4. Install the gland cap on the cylinder rod being extremely careful not to cut the rod seal on the threads of the rod or rod shoulder. If available use a sleeve to cover the rod threads or plastic electrical tape.

5. Install the piston on the rod and tighten the locknut to 90 ft-lbs (0.56 UNF), 22 ft-lbs (0.75 UNF).

6. Spray the inside of the cylinder tube with lubricant to ease inserting the rod and piston. Insert the rod and piston into the cylinder tube. Tap the rod in with a rubber mallet if resistance is encountered.

7. Press on the lock ring and spread retaining ring to install onto the gland cap.

6.7 Hydraulic Valve Removal

1. Turn off the truck's power and activate the hydraulic functions in both directions several times to relief the built up hydraulic pressure.

2. Disconnect the hydraulic hoses from the truck at the attachments valve ports V1 (open) and V2 (close). (Figure 6-9)

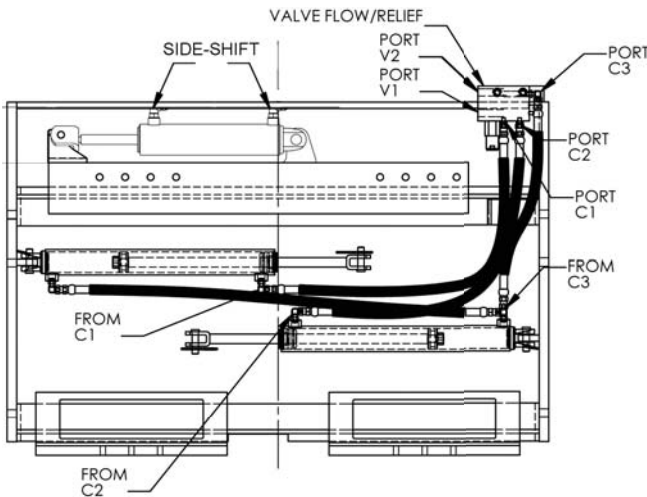

Figure 6-9, Hydraulic Hoses

3. Disconnect the hydraulic hoses at the valve ports C1 and C2.

4. Remove the valve mounting bolts and remove valve.

6.8 Hydraulic Valve Installation

1. Reassembly in the reverse order above.

2. Turn on the truck's power and activate the hydraulic functions several times to bleed out trapped air.

6.9 Torque Specifications

Unless otherwise specified

SAE Grade 5 Capscrews

Nominal Size	Thread Series	Inches	Torque (Ft-Lbs)	
			Dry K=0.20	Lubed K=0.15
1/4	20 UNC	0.2500	8	6
	28 UNF		10	7
5/16	18 UNC	0.3125	17	13
	24 UNF		19	14
3/8	16 UNC	0.3750	31	23
	24 UNF		35	26
7/16	14 UNC	0.4375	49	37
	20 UNF		55	41
1/2	13 UNC	0.5000	75	57
	20 UNF		85	64
9/16	12 UNC	0.5625	110	82
	18 UNF		120	91
5/8	11 UNC	0.6250	150	115
	18 UNF		170	130
3/4	10 UNC	0.7500	265	200
	16 UNF		295	225
7/8	9 UNC	0.8750	430	320
	14 UNF		475	355
1	8 UNC	1.0000	645	485
	14 UNF		720	640
1-1/8	7 UNC	1.1250	795	595
	12 UNF		890	670
1-1/4	7 UNC	1.2500	1120	840
	12 UNF		1240	930

SAE Grade 8 Capscrews

Nominal Size	Thread Series	Inches	Torque (Ft-Lbs)	
			Dry K=0.20	Lubed K=0.15
1/4	20 UNC	0.2500	12	9
	28 UNF		14	10
5/16	18 UNC	0.3125	25	18
	24 UNF		27	20
3/8	16 UNC	0.3750	44	33
	24 UNF		49	37
7/16	14 UNC	0.4375	70	52
	20 UNF		78	58
1/2	13 UNC	0.5000	105	77
	20 UNF		120	90
9/16	12 UNC	0.5625	155	112
	18 UNF		170	130
5/8	11 UNC	0.6250	210	155
	18 UNF		240	180
3/4	10 UNC	0.7500	375	280
	16 UNF		420	315
7/8	9 UNC	0.8750	605	455
	14 UNF		670	500
1	8 UNC	1.0000	910	680
	14 UNF		1020	765
1-1/8	7 UNC	1.1250	1290	965
	12 UNF		1440	1080
1-1/4	7 UNC	1.2500	1820	1360
	12 UNF		2010	1500