

# Optional Equipment and Accessories

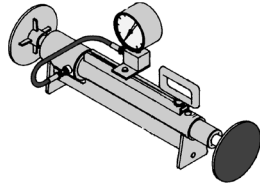

Control Knob



Clamp Force Gauge



Electric Cable Reel

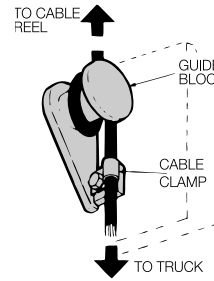

Electric Cable Guide



Hose Take-Up Kit

## Reel Accessories

Part No.	Description
2502016	Electric Cable Reel (Used with a solenoid valve)
Y054437	Electric Cable Guide (Protects cable from bending stress.)
Y410150	Hose Take-Up Kit (For 2-stage mast with up to 25" free lift)

## Optional Mounting Hooks

	Description
Class II	Quick Change Hooks
Class III	Quick Change Hooks
Class IV	Quick Change Hooks
Class II / III	Dual Bolt-on Hooks
Class II / III	Dual Quick Change Hooks
Class III / IV	Dual Bolt-on Hooks
Class III / IV	Dual Quick Change Hooks
Pin/Shaft Mounting	See page J-6

Mounting other than shown, consult factory.

## Optional Electrical Equipment

Part No.	Description
Y088122.1	Control Knob – 2 Function (1 button)
Y088122.2	Control Knob – 3 Function (2 button)
Y088122.3	Control Knob – 4 Function (3 button)
2515313	Low Profile Switch
	Single Solenoid Installed on Attachment, 2 Func.
	Dual Solenoid Installed on Attachment, 3 Func.
	Single Solenoid - Valve Only - To install on Truck
	Dual Solenoids - Valves Only - To install On Truck
	Note: Does not include any electrical adaptation for truck.

## Low Pressure Tank Line Kit

Kit includes hose and hardware necessary to tee another hydraulic line directly into an existing low pressure return to tank hose.

Part No.	Truck Tank Line Hose ID	Attachment Return Hose ID
2501369	0.75 inch	0.50 inch
2501370	1.00 inch	0.50 inch
2501371	1.25 inch	0.50 inch
Consult factory	1.25 inch	0.75 inch
Consult factory	1.50 inch	0.75 inch

## Flow Control Valve, Single function

Reduces the flow to the attachment. Bi-Directional for one hydraulic circuit (both lines). Does not include hoses or fittings. Repair seal kits available. Use in conjunction with Low Pressure Tank Line Kit.

Temperature limits: -25 to 225 Deg F (contact factory for higher temperature seals)

Maximum pressure: 3000 PSI

Approx. Size: 30 GPM input valve, 5" x 5" x 1.5" with #8 SAE ports  
60 GPM input valve 6.5" x 6.5" x 2" with #12 SAE ports

Part No.	Max. Input	Max. Flow
2501634	30 GPM	3.5 GPM
2501635	30 GPM	5.0 GPM
2501636	30 GPM	7.0 GPM
2501469	30 GPM	10.0 GPM
2501637	30 GPM	12.0 GPM
2507641	60 GPM	7.0 GPM
2504536	60 GPM	24.0 GPM



## Relief Valve Kit, Single Pressure Setting

Provides lower pressure setting for one hydraulic line. Kit includes valve, valve mounting hardware, bolt-on or weld-on valve mounting plate, and fittings with #8 male JIC connections available. Pressure setting is difference between ports, not absolute. Repair seal kits available.

Temperature limits: -30 to 240 degrees F. (Consult factory for higher temperatures)

Maximum inlet Pressure: 3000 psi.

Input Flow range: 2-20 GPM

Pressure setting range: 300 – 1,800 psi

Part No.	Type
2502580	Kit
YL-279	Valve Only



## Pressure Gauge

Glycerin filled with stainless steel case and 1/4" male NPT connection.

Pressure range: 0-3000 psi

Approx. size: 2.50" diameter

Temperature range: -40 to 180 Degrees F.

Part No.
2520877



## Hydraulic Quick Disconnect Couplers

Provides for fast connection/disconnection of attachment hoses without the use of hand tools. Includes one pair of couplers to accommodate one hydraulic function.

Made from zinc plated hardened carbon steel.

Maximum Pressure: 4000 psi

Temperature Range: -30 to 240 Deg F

Repair seal kits available.

Part No.	Port Sizes	Flow
YOB-26	3/8" Female NPT	Up to 6 GPM
YOB-16	1/2" Female NPT	Up to 12 GPM
Consult Factory	SAE Oring ports	



## Relief Valve, Bi Directional

Provides Bi-directional lower pressure setting for one hydraulic circuit (both lines).

Four #6 SAE oring ports.

Approx. size 5.25" x 3" x 1.25"

Pressure setting is difference between ports, not absolute.

Temperature limits: -30 to 240 degrees F. (Consult factory for higher temperatures)

Maximum inlet Pressure: 3,000 psi. Input Flow range: 2-20 GPM

Possible Pressure settings: 100 – 3,000 psi

Does not include hoses or fittings.

Part No.	Pressure Setting
Y163524	750 psi
Contact factory	Others



## Manual 3 Position Pressure Regulator Kit

(Three adjustable pressure settings plus truck relief)

Allows operator to adjust the clamping force from load to load to reduce load damage. Regulates pressure in one line only. Kit includes valve, valve mounting hardware, weld on valve mounting plate, 3000 psi gauge and fittings with #8 male JIC connections available. Pressure setting is difference between ports, not absolute. Repair seal kits available.

Temperature limits: -25 to 225 degrees F. (Consult factory for higher temperatures)

Maximum inlet Pressure: 3000 psi. Input Flow range: 2-20 GPM

Pressure adjustment (3): 100 – 3,000 psi for each

Factory Pressure Settings: 800, 1200 and 1800 PSI

Part No.	Type
2500194	Kit
YL-354	Valve Only



## Recommended Hose Sizes

Recommended flow adds approximately 5 psi/foot of pressure loss.

Hose Size	Hose ID	Recommended Flow
#4	1/4"	Up to 2.3 GPM
#5	5/16"	Up to 5.3 GPM
#6	3/8"	Up to 8.0 GPM
#8	1/2"	Up to 16.0 GPM
#10	5/8"	Up to 30.0 GPM
Consult factory	Others	Consult Factory

# Clamp Opening Control Kits

- ▶ Requires the operator to perform two distinct actions to release the clamping force of an attachment
- ▶ Conforms to ANSI/ITSDF B56.1, Section 7.25.7 requirements
- ▶ May be easily retrofitted onto existing installations

Beginning October 7, 2010, all lift truck attachments with load bearing clamps must conform to ANSI/ITSDF B56.1, Section 7.25.7, which states:

*"The manual operation or physical action of the control used to release a load-bearing clamp shall require two distinct motions or operations by the operator before the clamp is opened and the load-bearing force is released. For example, move the lever or handle to the left (or right) and then forward (or down), or, depress a button on the lever or handle and then move the lever or handle forward (or down)."*

Long Reach Clamp Opening Control Kits conform to this requirement, by requiring the operator to depress a button and move a hand lever to release the load-bearing force of the clamp. These kits are easily installed on either new installations, or retrofitted onto existing installations. Illustrated instructions are included with the kits.

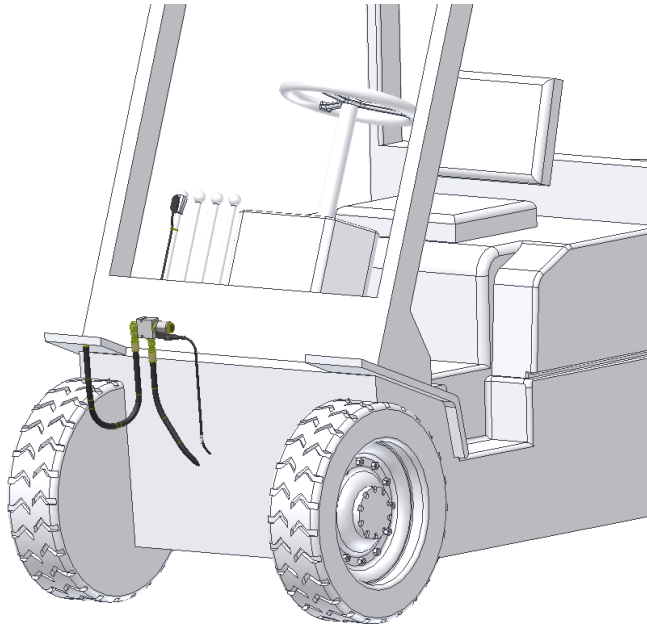

## Clamp Opening Control Kits

Part Number	Description
2520519	Kit for 12V Lift Trucks
2520520	Kit for 24V Lift Trucks
2520521	Kit for 36V Lift Trucks
2520522	Kit for 48V Lift Trucks

## Pin Mounting Required Dimensions

Pin Carriage Information. Please furnish the dimensional data shown below at the time of order. Fill in the measurements in the spaces provided in the chart next to each letter.

A	
B	
C	
D	
E	
F	
G	

H	
I	
J	
K	
L	
M	

