

Broke Paper Clamps

- ▶ Firmly grips and holds broke on forks while traveling
- ▶ Extends fully out of the way to allow normal use of forks
- ▶ Variety of mountings available, including integral, weld-on, and pin
- ▶ Quick change lower hooks included

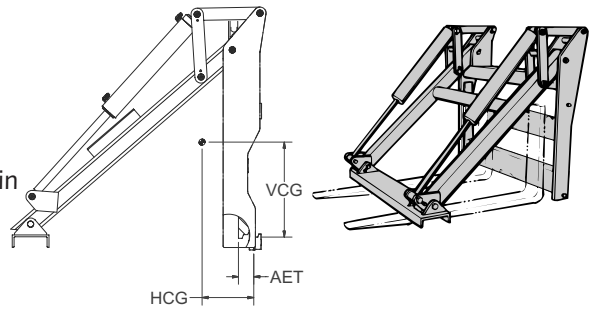

Broke Clamps, 1 Function

Model Number	Capacity (lb @ 24")	Mounting Class	Min. Fork Length (in)	Overall Width (in)	HCG (in)	AET ¹ (in)	Weight (lb)
QCNB040A37	4,000	II	36	37			
QCNB040A42	4,000	II	36	42			
QCNB100B42	10,000	III	42	42	Consult Factory	Consult Factory	Consult Factory
QCNB100B48	10,000	III	42	48			
QCNB140C48	14,000	IV	48	48			

¹ AET is measured to face of broke clamp carriage bars. AET does not include forks mounted to broke clamp.

NOTES: For sideshifting, add \$140 to list price. Prices do not include forks. Use standard ITA forks. Weld-on design available.

Recommended Hydraulic Supply

Model Number	Flow (gpm)	Max psi
All Models	4-8	2,000

Hydraulic flow less than minimum may reduce operating speed and/or cause irregular arm movement. Higher flow may result in heat build-up, erratic operation and shortened hydraulic system life.

Minimum Truck Carriage Width

Model Number	Minimum Truck Carriage Width (in)
QCNB040A37	30
QCNB040A42	36
QCNB100B42	36
QCNB100B48	42
QCNB140C48	42

RHC-65 Series Roll Head Clamps (Grappler)

- ▶ Positive lever arm clamping force applied to roll
- ▶ Adjustable roll ranges and clamping force
- ▶ Automatic latch and unlatch
- ▶ Flattened expanded metal pad surface for sure grip

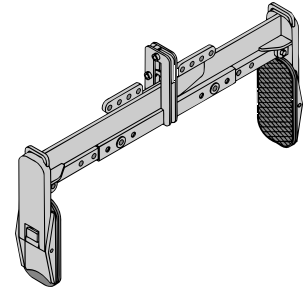

Roll Head Clamps

Model Number	Capacity (lb)	Roll Range Dia. (in)	Adjustable Range (in)	Pad Size, H x W (in)	Weight (lb)
RHC65-50	6,500	38.5-50	2" increments (1" per arm)	10 x 5.5	315
RHC65-56	6,500	38.5-56	2" increments (1" per arm)	10 x 5.5	315

NOTE: Overhead separators, bridles (cable) and operator pull cord (latch/release) not included.

Clamp Opening Control Kits

- ▶ Requires the operator to perform two distinct actions to release the clamping force of an attachment
- ▶ Conforms to ANSI/ITSDF B56.1, Section 7.25.7 requirements
- ▶ May be easily retrofitted onto existing installations

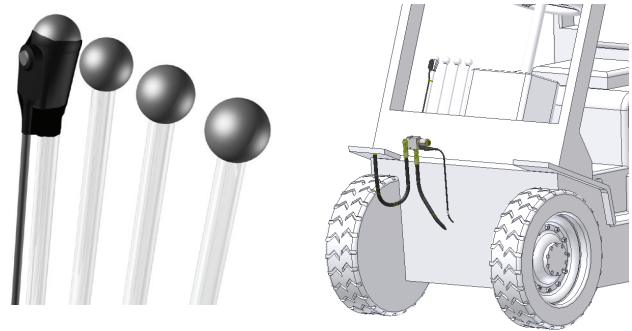

Clamp Opening Control Kits

Part Number	Description
2520519	Kit for 12V Lift Trucks
2520520	Kit for 24V Lift Trucks
2520521	Kit for 36V Lift Trucks
2520522	Kit for 48V Lift Trucks