

Sideshifting, Fork Positioning Integral Carriages

- ▶ Hydraulically position your forks; uses truck's forks
- ▶ Additional sideshift stroke available
- ▶ Popular, durable top linear ball bearing & hardened steel heel rollers

Hook Type, 2 Functions

Model Number	Capacity @ 24" (lb)	Fork Bar Class	Fork Spread ITO (in)	Total Shift (in)
TNGA100B44	10,000	III	0-44	8
TNGA100B50			0-50	
TNGA100B56			0-56	
TNGA100B60			0-60	
TNGA155C48			0-48	
TNGA155C60	15,500	IV	0-60	12
TNGA155C72			0-72	
TNGA155C84			0-84	
TNGA177C48			0-48	
TNGA177C60	17,700	IV	0-60	12
TNGA177C72			0-72	
TNGA177C84			0-84	
TNGA250D60			0-60	
TNGA250D72	25,000	V	0-72	12
TNGA250D84			0-84	
TNGA250D96			0-96	

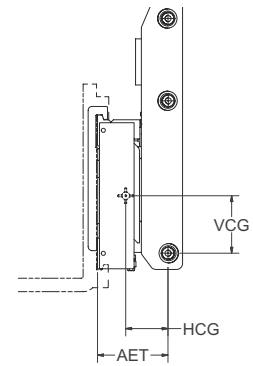
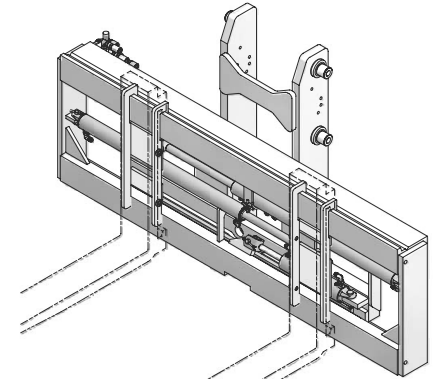

Pin Type, 2 Functions

Model Number	Capacity @ 24" (lb)	Overall Width (in)	Fork Spread ITO (in)	Total Shift (in)
TNGA100P58	10,000	62	4-58	10
TNGA155P70	15,500	74	4-70	12
TNGA180P78	18,000	82.5	4-78	12
TNGA225P78	22,500	83	4-78	12
TNGA250P78	25,000	83	4-78	12
TNGA300P78	30,000	83	4-78	12
TNGA360P78	36,000	83	5-78	12

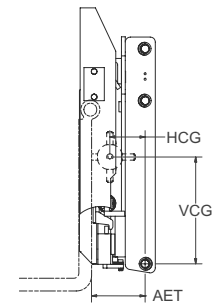
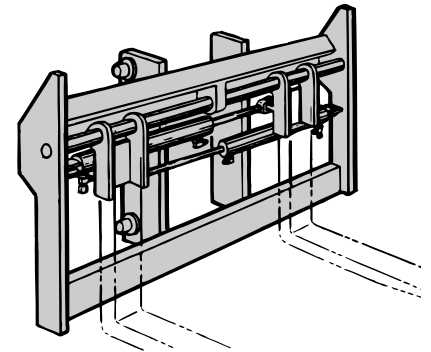

NOTE: Fork positioning cylinders are hoses together for simultaneous movement. The cylinders are hoses to a #6 terminus on the RH of the carriage. Other hoses options available.